

SMD Choke Coils

Series: **P**
 Type: **ELLATP**

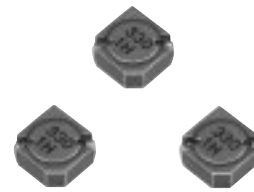

Type ELLATP

■ Features

- Magnetic shielded structure
- Low DC resistance and large current capability
- Available on tape and reel for automatic insertion
- The new version of ELLATV serie
- RoHS compliant

■ Recommended Applications

- DC-DC converter circuitry for computer peripherals and amusement equipment.
- Chopper circuit decoupling chokes for DC-DC converter circuitry.

■ Standard Packing Quantity

- 500 pcs./Reel

■ Soldering Conditions

Please see Page 169

■ Safety Precautions

Please see Page 170

■ Explanation of Part Numbers

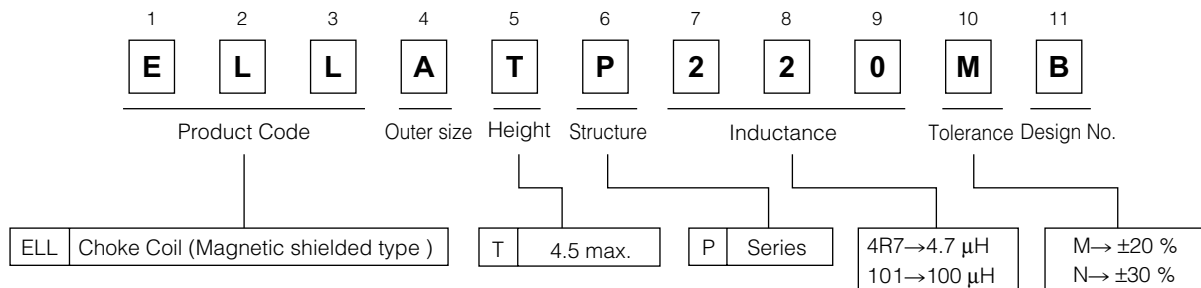

■ Dimensions in mm (not to scale)

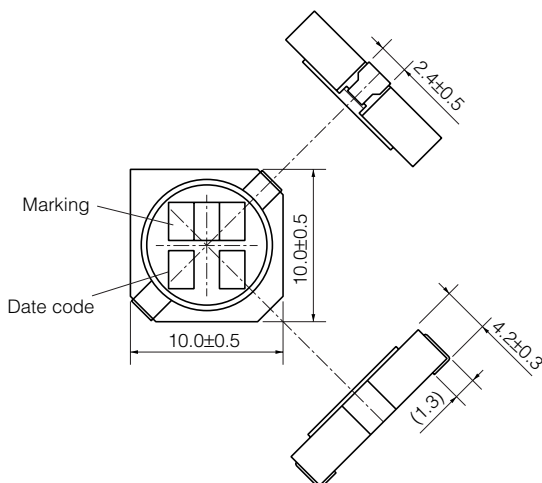

■ Recommended Land Pattern in mm (not to scale)

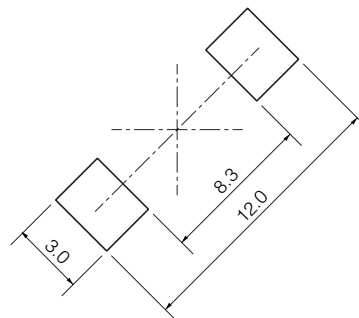

NEW

■ Standard Parts

Part Number	Inductance (100 kHz)		R _{DC} (at 20 °C)		Saturation Rated Current ^{*1} (mA max.)	Temperature Rise Current ^{*2} (mA max.)	Marking		
	(μH)	Tol.	(mΩ)	Tol.					
ELLATP1R0NB	1.0	±30 %	3.6	±30 %	9000	8000	1R0		
ELLATP1R5NB	1.5		4.4		8000	7000	1R5		
ELLATP2R7NB	2.7		5.4		5500	6500	2R7		
ELLATP3R3NB	3.3		7.5		5350	5500	3R3		
ELLATP4R7NB	4.7		9.1		4500	5000	4R7		
ELLATP5R1NB	5.1		12		4350	4500	5R1		
ELLATP6R8NB	6.8		15		4000	4000	6R8		
ELLATP8R2NB	8.2		18		3700	3700	8R2		
ELLATP100MB	10.0		±20 %		22	±20 %	3300	3300	100
ELLATP120MB	12.0				25		2900	2900	120
ELLATP150MB	15.0	29		2700	2700		150		
ELLATP220MB	22.0	38		2200	2500		220		
ELLATP270MB	27.0	47		1900	2200		270		
ELLATP330MB	33.0	59		1800	2000		330		
ELLATP390MB	39.0	66		1600	1800		390		
ELLATP470MB	47.0	80		1500	1700		470		
ELLATP680MB	68.0	120		1100	1400		680		
ELLATP820MB	82.0	140		1050	1300		820		
ELLATP101MB	100.0	180		1000	1200		101		
ELLATP121MB	120.0	200		900	1000		121		
ELLATP151MB	150.0	250		780	900		151		
ELLATP181MB	180.0	320		750	750		181		
ELLATP221MB	220.0	360		700	700		221		
ELLATP331MB	330.0	550		550	600		331		
ELLATP471MB	470.0	780		470	500		471		
ELLATP681MB	680.0	1150		380	450		681		
ELLATP102MB	1000.0	1700		310	370		102		

*1 Saturation Rated Current : This DC current which causes a 30 % inductance reduction from its nominal value.
 *2 Temperature Rise Current : This indicates the value of current when temperature rise dt/t= 40 °C (at 20 °C).

■ Embossed Carrier Tape Dimensions in mm (not to scale)

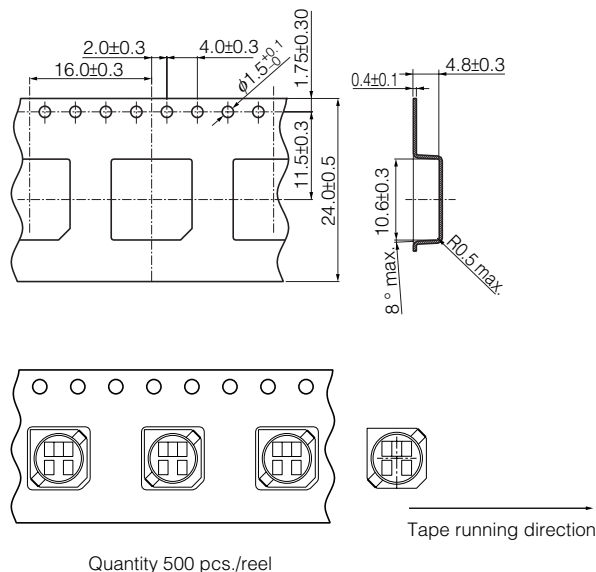

Quantity 500 pcs./reel