

Layout proposal/  
Layout Vorschlag

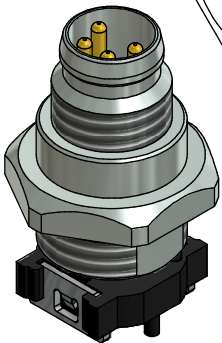
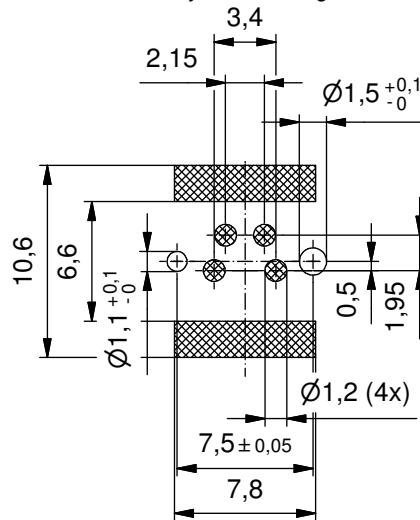

**Technical specification:**

**Technische Daten:**

Rated Voltage/ Bemessungsspannung:	50 V AC / 60 V DC
IEC 61076-2-104	
Current rating/ Strombelastbarkeit:	4 A bei 40°C
IEC 61076-2-104	
Insulation resistance/ Isolationswiderstand:	>=100 MΩ
IEC 60512	
Pollution degree/ Verschmutzungsgrad:	3/2
IEC 60664-1	
Degree of protection/ Schutzart:	IP 67, mated condition/ im verbauten Zustand
IEC 60529	
Temperature range/ Umgebungstemperatur:	-25°C ... +95°C
EN 60512-11-10	-40°C
EN 60512-11-4	-40°C ... +85°C
Mating cycles/ Steckzyklen:	>=100
IEC 60512-9a	

**Materials/**

**Werkstoffe:**

Contact/ Kontakt:	CuZn, Ni b / Au 0,2 gal.
Contact carrier/ Kontaktträger:	LCP GF, UL 94 V-0
Soldering sheet/ Lötblech:	CuZn, Ni / Sn
Sealing/ Dichtung:	FPM / NBR
Socket housing/ Flanschgehäuse:	CuZn, Ni



Suitable for reflow soldering  
max. 60s / 250°C/  
 Geeignet für Reflow Lötprozess  
max. 60s / 250°C

Coplanarity of all contacts and  
soldering sheets max 0,1mm/  
Koplanarität aller Kontakte und  
Lötbleche max 0,1mm

**Installation specification/**

**Montagedaten:**

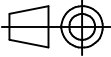
Recommended torque/ empfohlenes Drehmoment:	1-1,2 Nm
Conec Installation tool/ Montagewerkzeug:	Torque wrench/ Drehmomentschlüssel: 36-000200 Insert across flats 13/ Steckinsatz SW13: 36-000220
Installation hole/ Einbauöffnung:	See fig.2 42K1A1119 siehe Fig.2 42K1A1119

Part no. packing unit tape & reel/ Art.-Nr. Verpackungseinheit Rolle:	42-01253TR	Part no. packing unit in bulk/ Art.-Nr. Verpackungseinheit lose:	42-01253	Description/ Bezeichnung:	SAL - 8 - FS4 - X9 / SMT	Pos/ Pol.:	4	
 dim. in mm		<b>Male socket M8x1, SMT, frontmounting, screwable / snap-in Flanschstecker M8x1, SMT, Frontmontage, schraubbar / schnappbar</b>						
general tolerance/ Allgemeintoleranz:	0 ± 0,50mm 0,0 ± 0,25mm 0,00 ± 0,10mm * ± 5°						Date/ Datum	Name
drawn/ gez.	26.02.15						Gitinow	
appd./ gepr.	18.03.15						Schramm	
Index: Index "b": 12.06.17 cbe Ä6740	scale/ Maßstab:			dwg no / Z.-nr.:	42K1A779	DIN- A4		
Status: InBearbeitung	2,5:1 (2:1)					1 / 1		
RoHS & REACH compliant/konform								

The reproduction, distribution and utilization of this document as well as the communication of its contents to others without express authorization is prohibited. Offenders will be held liable for the payment of damages. All rights reserved in the event of the grant of a patent, utility model or design. Weitergabe sowie Vervielfältigung dieses Dokuments, Verwertung und Mitteilung seines Inhalts sind verboten, soweit nicht ausdrücklich gestattet. Zuwiderhandlungen verpflichten zu Schadenersatz. Alle Rechte für den Fall der Patent-, Gebrauchsmuster- oder Geschmacksmustereintragung vorbehalten.