

THIS DOCUMENT IS THE PROPERTY OF KEYSTONE ELECTRONICS CORP. AND SHALL NOT BE REPRODUCED, DISTRIBUTED OR USED AS A BASIS FOR MANUFACTURE WITHOUT PRIOR WRITTEN PERMISSION FROM KEYSTONE ELECTRONICS CORP.

ACTUAL SIZE

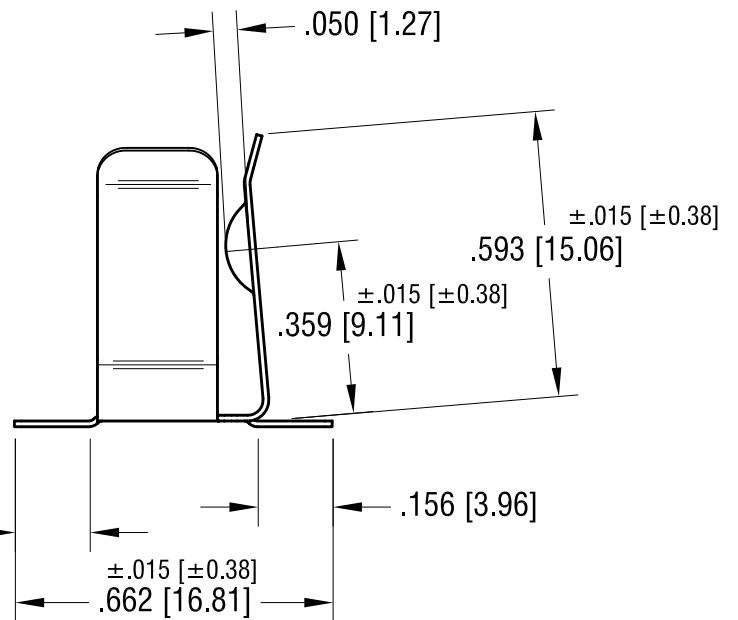

MOUNTING PAD LAYOUT. REQUIRED SPACING FOR 'A' OR 'AA' BATTERIES

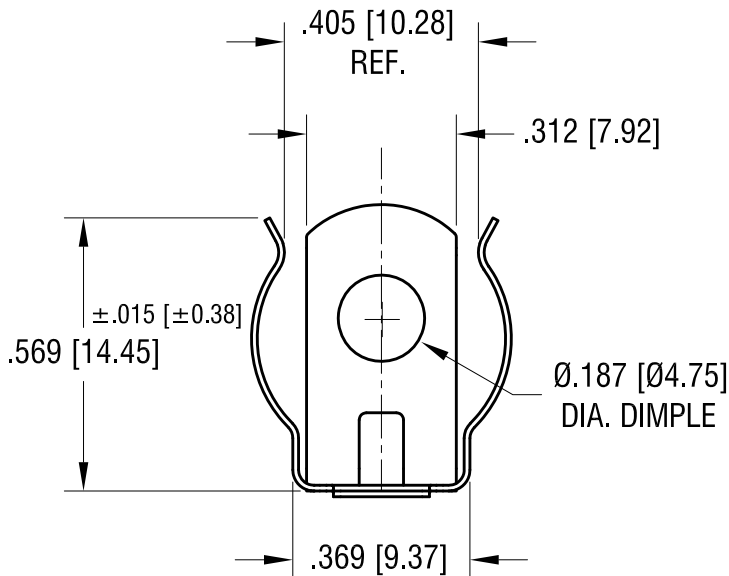
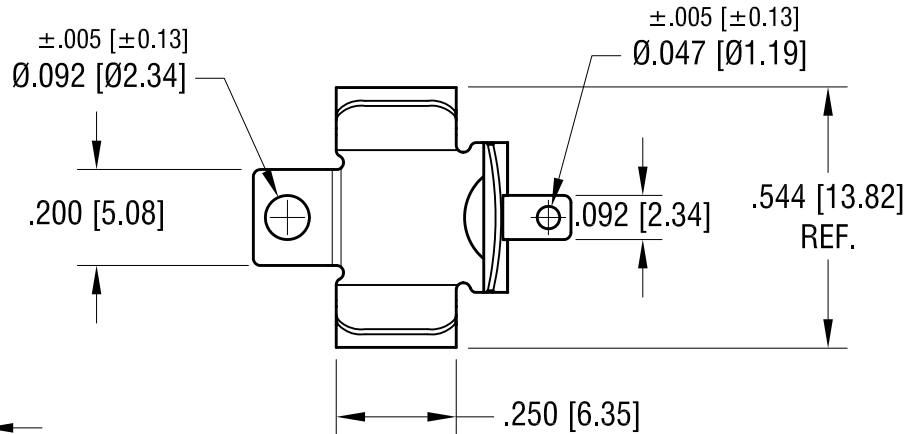
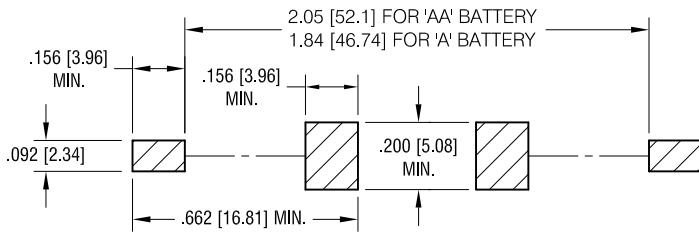

NOTE:

1. HEAT TREAT TO SPRING TEMPER.

**KEYSTONE ELECTRONICS CORP.**

www.keyelco.com • NEW HYDE PARK, NY 11040 • Tel (516) 328-7500

PART NAME		'A' & 'AA' BATTERY HOLDER	
MATERIAL		.012 [0.30] TH'K ANNEALED SPRING STEEL	
FINISH		DRN BY	DATE
TIN NICKEL PLATE		NT	10.16.08
		APP'D	SCALE
		LN	2.5X
TOLERANCES	INCH [MM]	CODE	DWG NO.
DECIMAL	±.010 [±0.25]	C	
ANGULAR	± 2°		
UNLESS OTHERWISE SPECIFIED			

10.06.16	CHANGE AS PER ECR 16-067	C
10.20.09	CHANGE AS PER ECN 99-152	B
1.05.09	CHANGE AS PER ECN 09-001	A
DATE	DESCRIPTION	REV.

53