

# 億力光電股份有限公司

## EVERVISION ELECTRONICS CO., LTD.

### Product Specification For LCD Module

(KVPF-7B-002-16)

Model NO. : VGG804830-0TSLWB(RoHS)

REVISION : 4

APPROVAL FOR SPECIFICATIONS ONLY

APPROVAL FOR SPECIFICATIONS AND SAMPLE

CUSTOMER :

STD.

APPROVED BY :

### EVERVISION LCM R&D CENTER

APPROVED BY

CHECKED BY

PREPARED BY



DIRECTOR



MANAGER



Mechanism Engineer



Electronic Engineer

億力光電股份有限公司總公司  
EVERVISION ELECTRONICS CO., LTD.  
新北市中和區建一路186號6樓  
6F., No.186, Jian 1st Rd., Zhonghe Dist.,  
New Taipei City 235, Taiwan  
TEL : +886 2 8227-2788  
FAX : +886 2 8227-2799

億力光電股份有限公司台中分公司  
EVERVISION ELECTRONICS CO., LTD.  
-Taichung Branch  
台中市潭子區建國路19號  
No.19, Jianguo Rd., Tanzi Dist.,  
Taichung City 427, Taiwan  
TEL : +886 4 2532-8889  
FAX : +886 4 2532-6689

勁佳光電(昆山)有限公司  
VBEST ELECTRONICS(KUNSHAN) Co., Ltd.  
江蘇省昆山市玉山鎮高科技工業園城北路8號  
No.8, Chengbei Rd., Hi-Tech Industry Park,  
Yushan Town, Kunshan City, Jiangsu, China.  
TEL : +86 512 5778 7288  
FAX : +86 512 5777 0688

勁佳光電(昆山)有限公司東莞分公司  
VBEST ELECTRONICS(KUNSHAN) Co., Ltd.  
- DongGuan Branch  
東莞市莞城區東縱大道天寶路23號  
No.23 Tian Bao Rd., Dong Zong St.,  
Dong Guan City, Guang Dong, China.  
TEL : +86 769 3887 5000  
FAX : +86 769 3896 0580

<http://www.evervisionlcd.com>

<b>EVERVISION</b>	<b>MODEL NO.</b>		<b>PAGE</b>
	VGG804830-0TSLWB	SPEC SAMPLE	2

## 1. Table of Contents

<b>No.</b>	<b>Contents</b>	<b>Page</b>
1	Table of Contents	2
2	Record of Revisions	3
3	Module Numbering System	4
4	Application	5
5	Features	5
6	General Specifications	5
7	Absolute Maximum Ratings	6
8	Electrical Characteristics	7
9	Block Diagram	8
10	Input / Output Terminals Pin Assignment	9
11	Interface Timing	15
12	Optical Characteristics	17
13	Reliability Test	20
14	Packaging	21
15	Precautions	22
16	Outline Drawing	24
17	Definition of Labels	25
18	Incoming Inspection Standards	27



**3. Module Numbering System**

**V G G 8048 30 – 0 T S L W B**

Serial No.:A~Z

Backlight Color:

N: Without Backlight;  
 A: Amber; B: Blue; G: Green;  
 L: Yellow; O: Orange; R: Red;  
 W: White; Y: YellowGreen;  
 X: Others

Backlight Type:

N: Without Backlight; E: EL; F: CCFL;  
 L: General LED; H: High NTSC LED ;  
 R: RGB LED; X: Others

LCD Model:

T: TN; H: HTN; G: STN Gray, Y: STN Yellow;  
 B: STN Blue; W: FSTN Black/White;  
 C: CSTN; F: TFT; O: OLED; P: PLED;  
 L: LTPS; N: Others

LCD Type:

R: Reflective/Positive;  
 S: Reflective/Negative ;  
 F: Transflective/Positive ;  
 G: Transflective/Negative ;  
 U: Transmissive/Positive ;  
 T: Transmissive/Negative ; N: Others

Temperature Range & View Direction:

General Purpose : 1:6H 2:12H 3:3H 4:9H 5:Others  
 High Performance: 6:6H 7:12H 8:3H 9:9H 0:Others

STD Product Serial No.: 01~99

Customer Made Serial No.: A1,A2... A9,B1,B2... B9,C1..

Display Function:

Segment Number / Characters Lines / Column and Row Dots  
 / Length \* Width of Other

Display Type:

C: Character Type; G: Graphic Type; S: Segment Type; O: Other

Package Type:

B: COB; F: COF; G: COG; H: Heat Seal; S: SMT; T: TAB; O: Others

<b>EVERVISION</b>	<b>MODEL NO.</b>		<b>PAGE</b>
	VGG804830-0TSLWB	SPEC SAMPLE	5

#### 4. Application

This specification is applied to the 4.3 inch supported TFT-LCD module, and can display true 16.2M colors(8 bit/ color).The module is designed for PMP, GPS application and other electronic products which require flat panel display of digital signal interface. The model is composed of a TFT LCD panel, a driver circuit and a back-light system.

#### 5. Features

- WVGA (800×480 pixels) resolution.
- 24 bit parallel RGB.
- HDMI Interface.

#### 6. General Specifications

Item	Specifications	Unit
Screen Size	4.3 (Diagonal)	inch
Display Format	800RGB(H)×480(V)	dot
Active Area	95.04(H)×53.856(V)	mm
PIXEL Pitch	0.1188(H)×0.1122(V)	mm
Pixel Configuration	RGB Vertical Stripe	-
Display Mode	IPS Type / Transmissive Mode / Normally Black	-
Surface Treatment	Anti-Glare	-
Viewing Direction	Full view angle	-
Outline Dimension	125.5(W)×67.2(H)×8.15(D)	mm
Weight	( 76 )	g
RoHS Compliance	Evervision certifies this product to be in compliance with European Union Directive 2015/863/EU on the restriction of certain hazardous substances in electrical and electronic equipment.	-

<b>EVERVISION</b>	<b>MODEL NO.</b>		<b>PAGE</b>
	VGG804830-0TSLWB	SPEC SAMPLE	6

## 7. Absolute Maximum Ratings

### 7.1 Absolute Ratings of Environment

Item	Symbol	Value		Unit	Note
		Min.	Max.		
Storage Temperature	T <sub>ST</sub>	-30	+80	°C	(1)(2)
Operating Ambient Temperature	T <sub>OP</sub>	-20	+70	°C	(1)(2)

Note1: Background color changes slightly depending on ambient temperature.

This phenomenon is reversible.

Note2: Please refer to item of RELIABILITY.

### 7.2 Electrical Absolute Ratings

#### 7.2.1 TFT-LCD Module

(Ta=25±2°C, GND=V<sub>SS</sub>=0V)

Item	Symbol	Value		Unit	Note
		Min.	Max.		
Power Supply Voltage	V <sub>CC</sub>	-0.3	24	V	-
BLEN	PWM	-0.3	6	V	-

## 8. Electrical Characteristics

### 8.1 TFT-LCD Module

(Ta=25±2°C)

Item	Symbol	Value			Unit	Note
		Min.	Typ.	Max.		
Power Supply Voltage	V <sub>CC</sub>	4.5	5.0	5.5	V	-
Power Supply Current	I <sub>CC</sub>	-	550	770	mA	(1)
Power Supply Voltage	V <sub>CC</sub>	11.5	12.0	12.5	V	-
Power Supply Current	I <sub>CC</sub>	-	200	280	mA	(1)
VSYNC Frequency	F <sub>V</sub>	-	60	-	Hz	-
PWM signal Low voltage	V <sub>PWML</sub>	0	-	0.8	V	-
PWM signal High voltage	V <sub>PWMH</sub>	2.0	-	3.6	V	-
PWM frequency	f <sub>PWM</sub>	0.1	-	200	kHz	Duty= 5%~100%
LED Life Time(25°C)	-	50000	60000	-	hr	(2)

Note (1) The specified power consumption is under the conditions at V<sub>CC</sub>=5V or 12V, F<sub>V</sub>=60Hz, whereas a power dissipation check pattern below is displayed.

White Pattern / 255 Gray



Active Area

Note (2) : LED life time is defined as under 25±2°C , when the average brightness decrease to 50% of original brightness.

**9. Block Diagram**

**TFT-LCD Module with Backlight Unit**

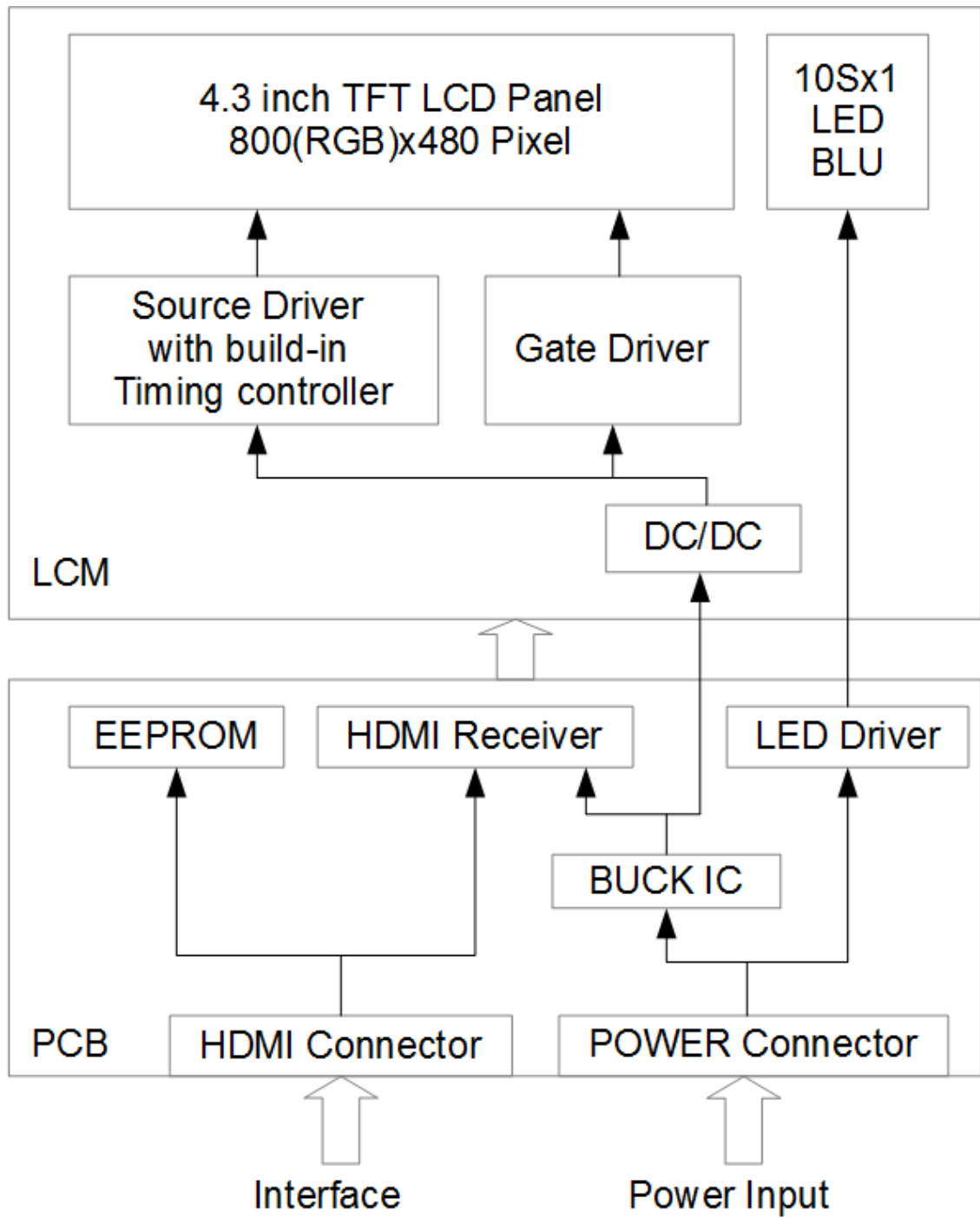



**10. Input / Output Terminals Pin Assignment****10.1 TFT-LCD Module**

Connector: Mini-HDMI Connector

No.	Symbol	I/O	Description
1	TMDS Data2 Shield	I	Ground
2	TMDS Data2+	I	Channel-2 positive receiver input – Positive side of channel-2 TMDS low-voltage signal differential input pair. Channel-2 receives red-pixel data in active display and CTL2, CTL3 control signals in blank.
3	TMDS Data2–	I	Channel-2 negative receiver input – Negative side of channel-2 TMDS low-voltage signal differential input pair.
4	TMDS Data1 Shield	I	Ground
5	TMDS Data1+	I	Channel-1 positive receiver input – Positive side of channel-1 TMDS low-voltage signal differential input pair. Channel-1 receives green-pixel data in active display and CTL1 control signals in blank.
6	TMDS Data1–	I	Channel-1 negative receiver input – Negative side of channel-1 TMDS low-voltage signal differential input pair.
7	TMDS Data0 Shield	I	Ground
8	TMDS Data0+	I	Channel-0 positive receiver input – Positive side of channel-0. TMDS low-voltage signal differential input pair. Channel-0 receives blue pixel data in active display and HSYNC, VSYNC control signals in blank.
9	TMDS Data0–	I	Channel-0 negative receiver input – Negative side of channel-0. TMDS low-voltage signal differential input pair.

No.	Symbol	I/O	Description
10	TMDS Data0 Shield	I	Ground
11	TMDS Clock+	I	Clock positive receiver input – Positive side of reference clock. TMDS low-voltage signal differential input pair
12	TMDS Clock–	I	Clock negative receiver input – Negative side of reference clock. TMDS low-voltage signal differential input pair
13	DDC Ground	I	Ground
14	N.C.	I	Not Connection
15	DCC_SCL	I	Serial Clock for EEPROM
16	DCC_SDA	I	Serial Data for EEPROM
17	Reserved (N.C. on device)	I	Not Connection
18	+5V Power	I	5V for EEPROM
19	HPD	I	Hot Plug Detect High: Active link Low: Inactive link

**10.2 Power Connector**

Connector: CI4412M2HR0 or compatible connector

No.	Symbol	Functions
1	VCC	Power supply for LCM
2	VCC	Power supply for LCM
3	BLEN	PWM Dimmer
4	NC	Not Connected
5	NC	Not Connected
6	NC	Not Connection
7	NC	Not Connection
8	NC	Not Connection
9	NC	Not Connection
10	NC	Not Connection
11	GND	Ground
12	GND	Ground

**10.3 Slider Switch**

Pin	Description	Note
1-2	PWM Dimmer	Default
2-3	HDMI Detection	-

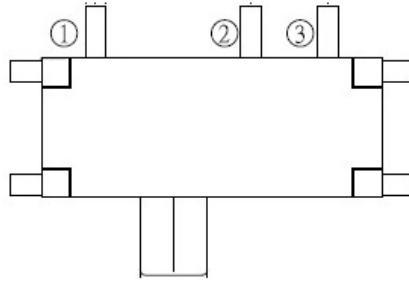

### 10.4 Color Data Input Assignment

The brightness of each primary color(red, green and blue) is based on the 8 bit gray scale data input for the color. The higher the binary input, the brighter the color. The table provides the assignment of color versus data input.

Color		Data Signal																							
		Red								Green								Blue							
		R7	R6	R5	R4	R3	R2	R1	R0	G7	G6	G5	G4	G3	G2	G1	G0	B7	B6	B5	B4	B3	B2	B1	B0
Basic Colors	Black	0	0	0	0	0	0	0	0	0	0	0	0	0	0	0	0	0	0	0	0	0	0	0	
	Red	1	1	1	1	1	1	1	1	0	0	0	0	0	0	0	0	0	0	0	0	0	0	0	
	Green	0	0	0	0	0	0	0	0	1	1	1	1	1	1	1	1	0	0	0	0	0	0	0	
	Blue	0	0	0	0	0	0	0	0	0	0	0	0	0	0	0	1	1	1	1	1	1	1	1	
	Cyan	0	0	0	0	0	0	0	0	1	1	1	1	1	1	1	1	1	1	1	1	1	1	1	
	Magenta	1	1	1	1	1	1	1	1	0	0	0	0	0	0	0	1	1	1	1	1	1	1	1	
	Yellow	1	1	1	1	1	1	1	1	1	1	1	1	1	1	1	0	0	0	0	0	0	0	0	
	White	1	1	1	1	1	1	1	1	1	1	1	1	1	1	1	1	1	1	1	1	1	1	1	
Gray Scale Of RED	Red(0) / Dark	0	0	0	0	0	0	0	0	0	0	0	0	0	0	0	0	0	0	0	0	0	0		
	Red(1)	0	0	0	0	0	0	1	0	0	0	0	0	0	0	0	0	0	0	0	0	0	0		
	Red(2)	0	0	0	0	0	0	1	0	0	0	0	0	0	0	0	0	0	0	0	0	0	0		
	:	:	:	:	:	:	:	:	:	:	:	:	:	:	:	:	:	:	:	:	:	:	:		
	:	:	:	:	:	:	:	:	:	:	:	:	:	:	:	:	:	:	:	:	:	:	:		
	Red(253)	1	1	1	1	1	1	0	1	0	0	0	0	0	0	0	0	0	0	0	0	0	0		
	Red(254)	1	1	1	1	1	1	1	0	0	0	0	0	0	0	0	0	0	0	0	0	0	0		
	Red(255)	1	1	1	1	1	1	1	1	0	0	0	0	0	0	0	0	0	0	0	0	0	0		
Gray Scale Of Green	Green(0) / Dark	0	0	0	0	0	0	0	0	0	0	0	0	0	0	0	0	0	0	0	0	0	0		
	Green(1)	0	0	0	0	0	0	0	0	0	0	0	0	0	0	1	0	0	0	0	0	0	0		
	Green(2)	0	0	0	0	0	0	0	0	0	0	0	0	0	1	0	0	0	0	0	0	0	0		
	:	:	:	:	:	:	:	:	:	:	:	:	:	:	:	:	:	:	:	:	:	:	:		
	:	:	:	:	:	:	:	:	:	:	:	:	:	:	:	:	:	:	:	:	:	:	:		
	Green(253)	0	0	0	0	0	0	0	0	1	1	1	1	1	1	0	1	0	0	0	0	0	0		
	Green(254)	0	0	0	0	0	0	0	0	1	1	1	1	1	1	1	0	0	0	0	0	0	0		
	Green(255)	0	0	0	0	0	0	0	0	1	1	1	1	1	1	1	0	0	0	0	0	0	0		
Gray Scale Of Blue	Blue(0) / Dark	0	0	0	0	0	0	0	0	0	0	0	0	0	0	0	0	0	0	0	0	0	0		
	Blue(1)	0	0	0	0	0	0	0	0	0	0	0	0	0	0	0	0	0	0	0	0	0	1		
	Blue(2)	0	0	0	0	0	0	0	0	0	0	0	0	0	0	0	0	0	0	0	0	0	1		
	:	:	:	:	:	:	:	:	:	:	:	:	:	:	:	:	:	:	:	:	:	:	:		
	:	:	:	:	:	:	:	:	:	:	:	:	:	:	:	:	:	:	:	:	:	:	:		
	Blue(253)	0	0	0	0	0	0	0	0	0	0	0	0	0	0	0	1	1	1	1	1	1	0		
	Blue(254)	0	0	0	0	0	0	0	0	0	0	0	0	0	0	0	1	1	1	1	1	1	0		
	Blue(255)	0	0	0	0	0	0	0	0	0	0	0	0	0	0	0	1	1	1	1	1	1	1		

**10.5 Power ON/OFF Sequence**

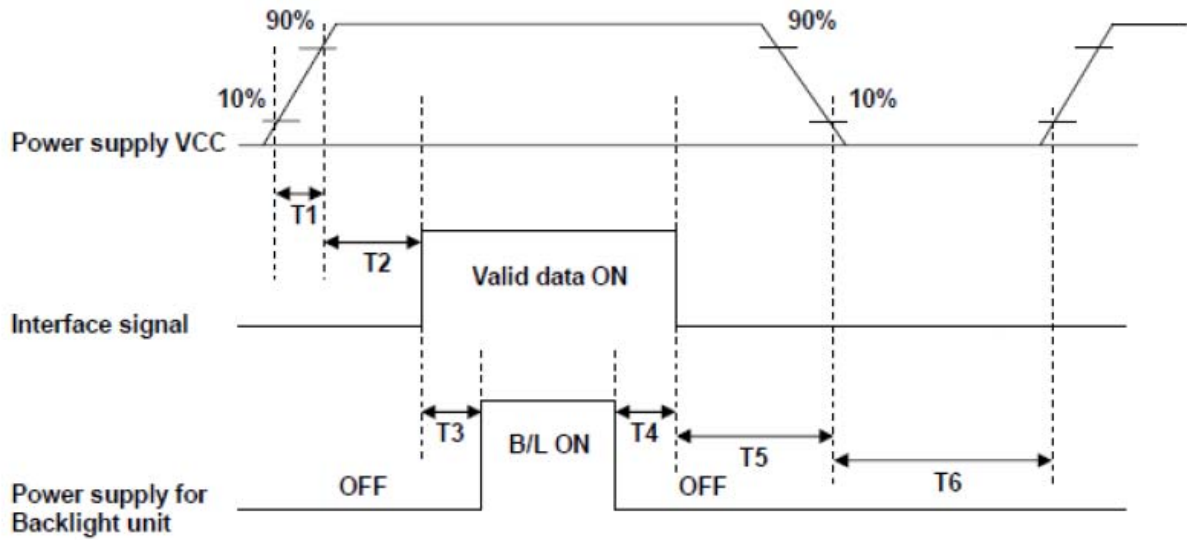

**POWER SEQUENCE TABLE**

Parameter	Value			Units
	Min.	Typ	Max.	
T1	0.5	-	10	ms
T2	40	-	80	ms
T3	200	-	-	ms
T4	200	-	-	ms
T5	40	-	80	ms
T6	1000	-	-	ms

## 11. Interface Timing

### 11.1. Timing Characteristic

#### Horizontal input timing

Parameter	Symbol	Value			Unit
		Min.	Typ.	Max.	
Horizontal Display Area	thd	800			DCLK
DCLK Frequency	fclk	-	30	50	MHZ
One Horizontal Line	th	889	928	1143	DCLK
HS pulse width	thpw	1	48	255	DCLK
HS Back Porch (Blanking)	thb	88			DCLK
HS Front Porch	thfb	1	40	255	DCLK

#### Vertical input timing

Parameter	Symbol	Value			Unit
		Min.	Typ.	Max.	
Vertical Display Area	tvd	480			H
VS period time	tv	513	525	767	H
VS pulse width	tvpw	3	3	255	H
VS Back Porch (Blanking)	tvb	32			H
VS Front Porch	tvfb	1	13	255	H

### 11.2. AC Electrical Characteristics (DVDD=VDD=3.0~3.6V, VSS=GND=0V)

Parameter	Symbol	Min	Typ.	Max.	Unit	Conditions
VDD Power on Slew Rate	T <sub>POR</sub>	-	-	20	ms	From 0V to 90% VDD
RSTB pulse width	T <sub>RST</sub>	50	-	-	us	Clkin=50MHz
CLKIN cycle time	T <sub>cph</sub>	20	-	-	ns	
CLKIN pulse duty	T <sub>cwh</sub>	40	50	60	%	
VSD setup time	T <sub>vst</sub>	8	-	-	ns	
VSD hold time	T <sub>vhd</sub>	8	-	-	ns	
HSD setup time	T <sub>hst</sub>	8	-	-	ns	
HSD hold time	T <sub>hhd</sub>	8	-	-	ns	
Data setup time	T <sub>d<sub>su</sub></sub>	8	-	-	ns	D[7:0], D1[7:0], D2[7:0] to clkin
Data hold time	T <sub>d<sub>hd</sub></sub>	8	-	-	ns	D[7:0], D1[7:0], D2[7:0] to clkin
Output stable time	T <sub>sst</sub>	-	-	6	us	10% to 90% target voltage. CL=120pF, R=10Kohm

### 11.3. Data Input Format

#### Vertical input timing

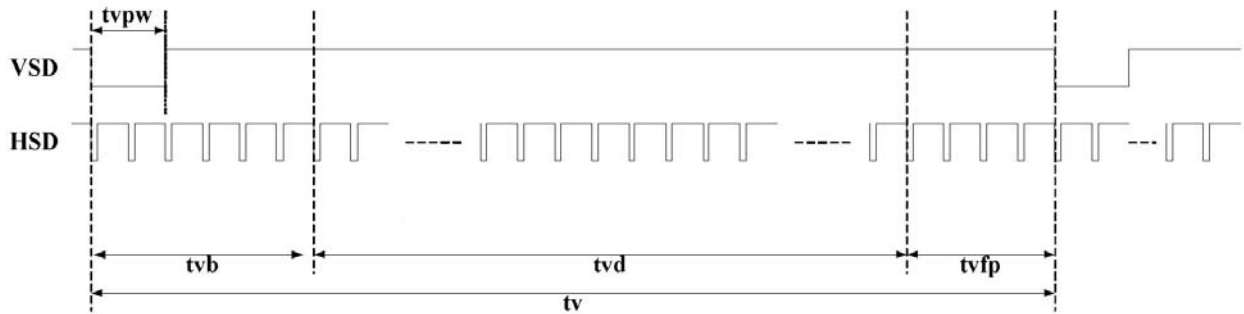

#### Horizontal input timing

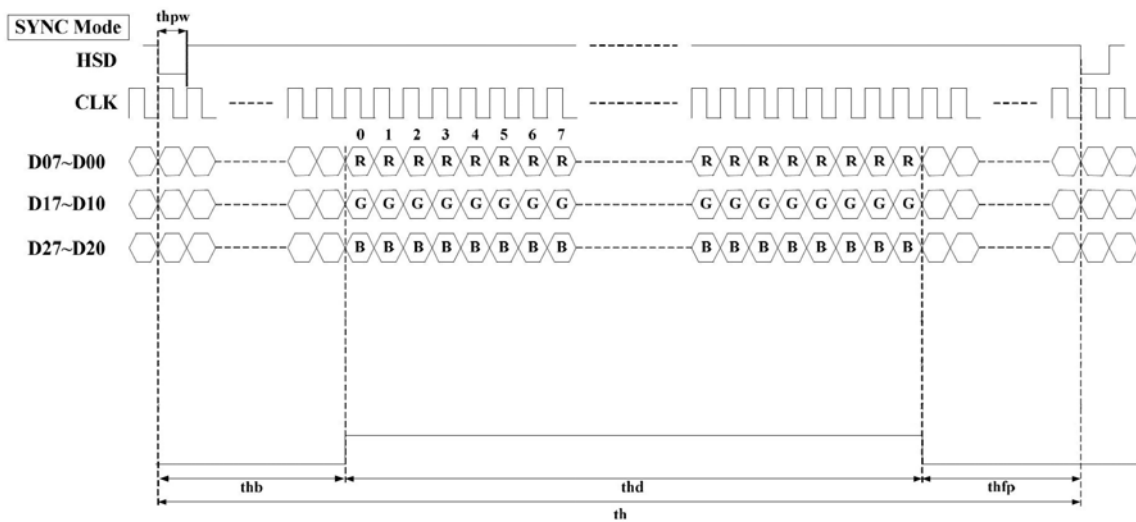

#### Input Clock and Data Timing Diagram

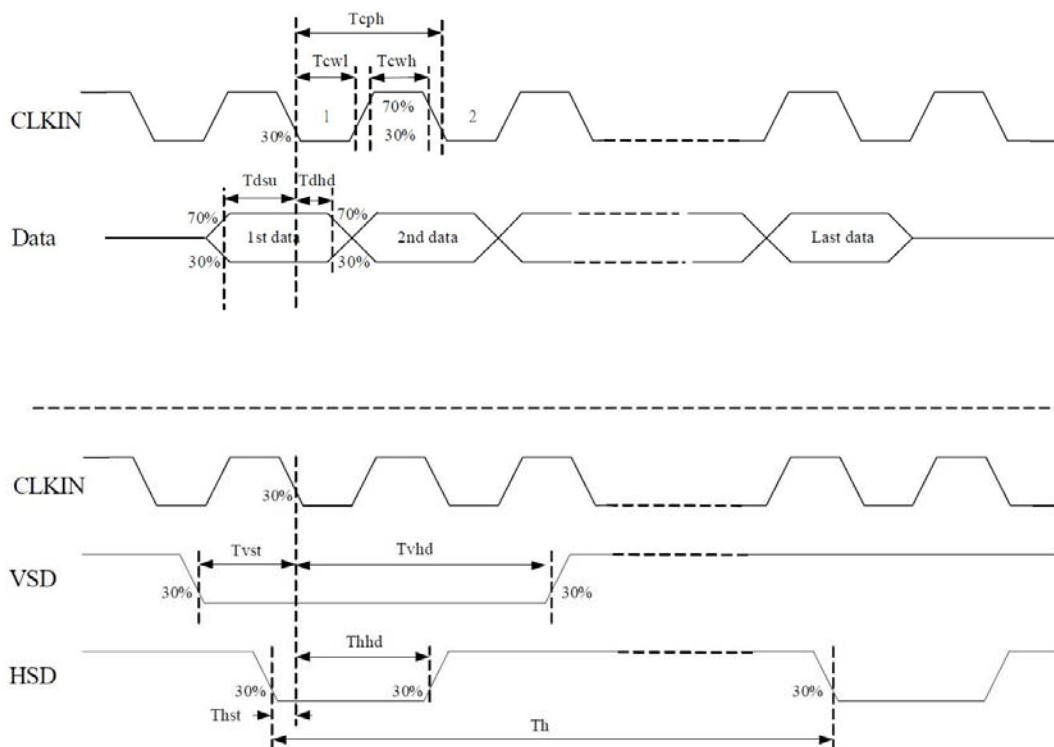



## 12. Optical Characteristics

The optical characteristics should be measured in a dark environment ( $\leq 1$  lux) or equivalent state with the methods shown in Note (5).

Item		Symbol	Conditions	Min.	Typ.	Max.	Unit	Note
Contrast Ratio		CR	$\theta_x=0^\circ, \theta_y=0^\circ$ Viewing Normal Angle	640	(900)	-	-	(2),(5)
Response Time		$T_{R+} T_F$		-	30	-	ms	(3)
Luminance (Center)		LC		640	(810)	-	cd/m <sup>2</sup>	(4),(5)
Brightness uniformity		BUNI		70	(75)	-	%	(5),(6)
Color Chromaticity	Red	Rx		0.545	0.595	0.645	-	(1),(5)
		Ry		0.305	0.355	0.405	-	
	Green	Gx		0.315	0.365	0.415	-	
		Gy		0.535	0.585	0.635	-	
	Blue	Bx	0.095	0.145	0.195	-		
		By	0.065	0.115	0.165	-		
	White	Wx	0.290	0.340	0.390	-		
		Wy	0.305	0.355	0.405	-		
Viewing Angle	Horizontal	$\theta_{x+}$	CR $\geq$ 10	70	(80)	-	deg.	
		$\theta_{x-}$		70	(80)	-		
	Vertical	$\theta_{y+}$		70	(80)	-		
		$\theta_{y-}$		70	(80)	-		

Note (1) Definition of Viewing Angle ( $\theta_x$ ,  $\theta_y$ ):

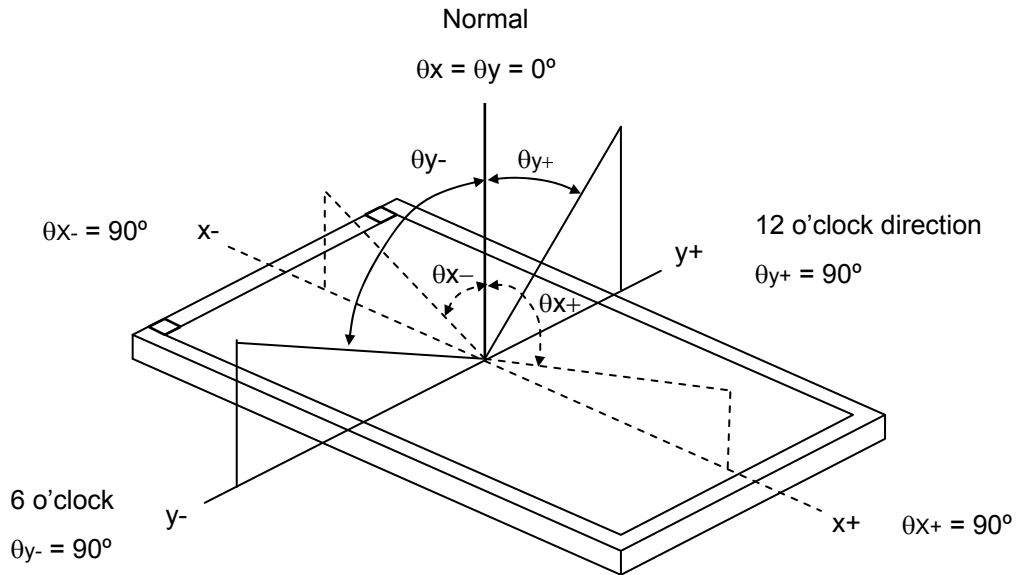

Note (2) Definition of Contrast Ratio (CR):

$$\text{Contrast ratio (CR)} = \frac{\text{Luminance measured when LCD on the "White" state}}{\text{Luminance measured when LCD on the "Black" state}}$$

Note (3) Definition of Response Time ( $T_R$ ,  $T_F$ ):

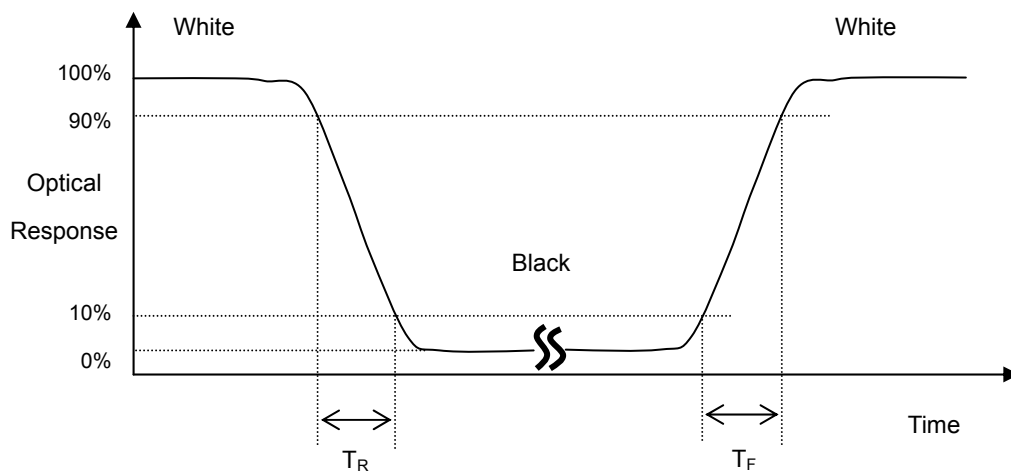

**Note (4) Measurement Set-Up:**

The LCD module should be stabilized at a given temperature for 30 minutes to avoid abrupt temperature change during measuring. In order to stabilize the luminance, the measurement should be executed after lighting Backlight for 30 minutes in a dark room or equivalent condition.

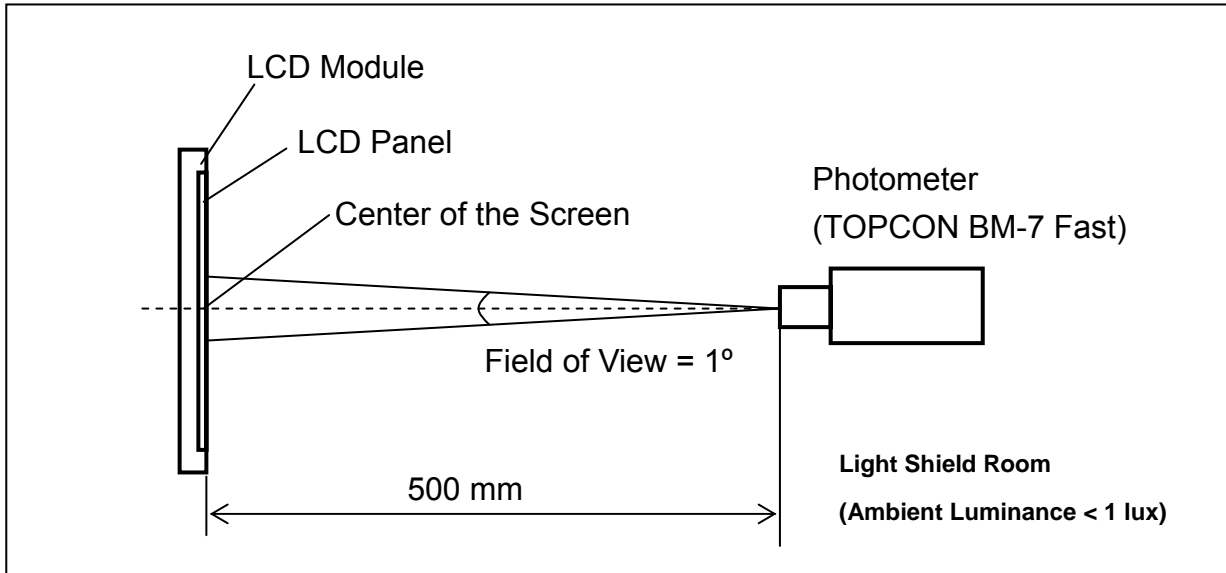

**Note (5) Definition of brightness uniformity**

$$\text{Brightness uniformity} = (\text{Min Luminance of 9 points}) / (\text{Max Luminance of 9 points}) \times 100\%$$

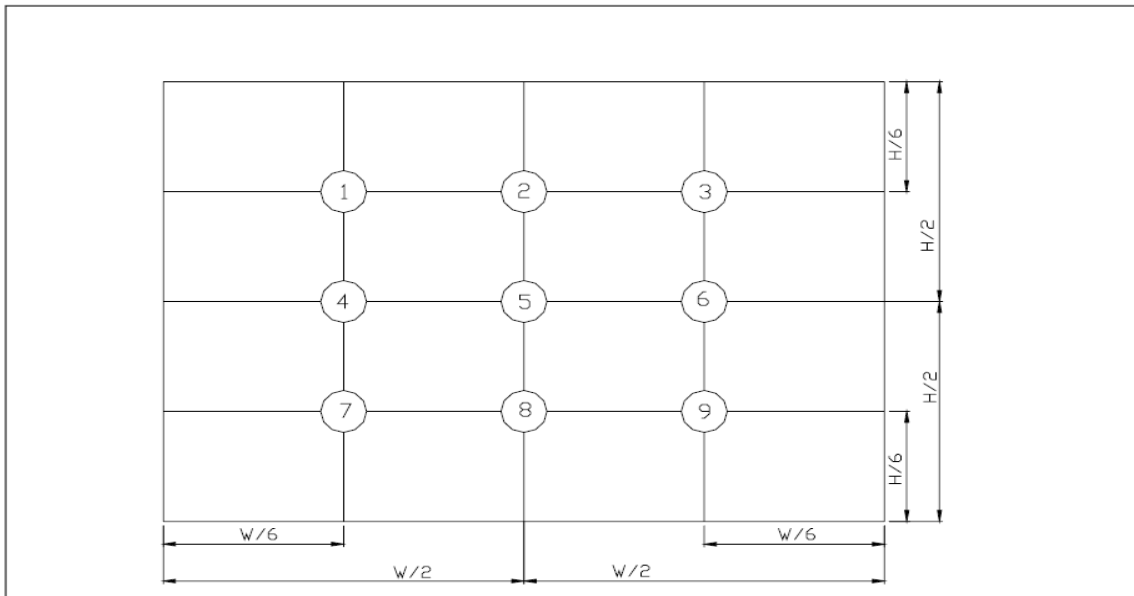

( 單位 : mm )

<b>EVERVISION</b>	<b>MODEL NO.</b>		<b>PAGE</b>
	VGG804830-0TSLWB	SPEC SAMPLE	20

### 13. Reliability Test

No.	Test Items	Test Condition	Remark
1	High Temperature Storage Test	T <sub>a</sub> = 80°C 240 hours	(1),(3),(4)
2	Low Temperature Storage Test	T <sub>a</sub> = -30°C 240 hours	(1),(3),(4)
3	High Temperature Operation Test	T <sub>s</sub> = 70°C 240 hours	(2),(3),(4)
4	Low Temperature Operation Test	T <sub>a</sub> = -20°C 240 hours	(1),(3),(4)
5	High Temperature and High Humidity Operation Test	T <sub>a</sub> =60°C 90%RH 240 hours	(3), (4)
6	Electro Static Discharge Test ( non-operating )	-Panel Surface/Top Case : 150pF, 330Ω Air : ±15kV, Contact: ±8kV	(3)
7	Mechanical Shock Test ( non-operating )	Half sine wave, 100G, 6ms 3 times shock of each six surfaces	(3)
8	Vibration Test ( non-operating )	Sine wave:10 ~ 55 ~ 10Hz amplitude:1.5mm 3 axis, 2 hours/axis	(3)
9	Thermal Shock Test ( non-operating )	-20°C (30min) ~ 70°C (30min) , 10 cycles	(3) , (4)
10	Drop Test(with Carton)	Height : 80cm 1 corner, 3 edges, 6 surfaces	(3)

Note 1 : T<sub>a</sub> is the ambient temperature of samples.

Note 2 : T<sub>s</sub> is the temperature of panel' s surface.

Note 3 : In the standard condition, there shall be no practical problem that may affect the display function.  
After the reliability test, the product only guarantees operation, but don' t guarantee all of the cosmetic specification.

Note 4 : Before cosmetic and function test, the product must have enough recovery time, at least 2 hours at room temperature.

**14. Packaging**

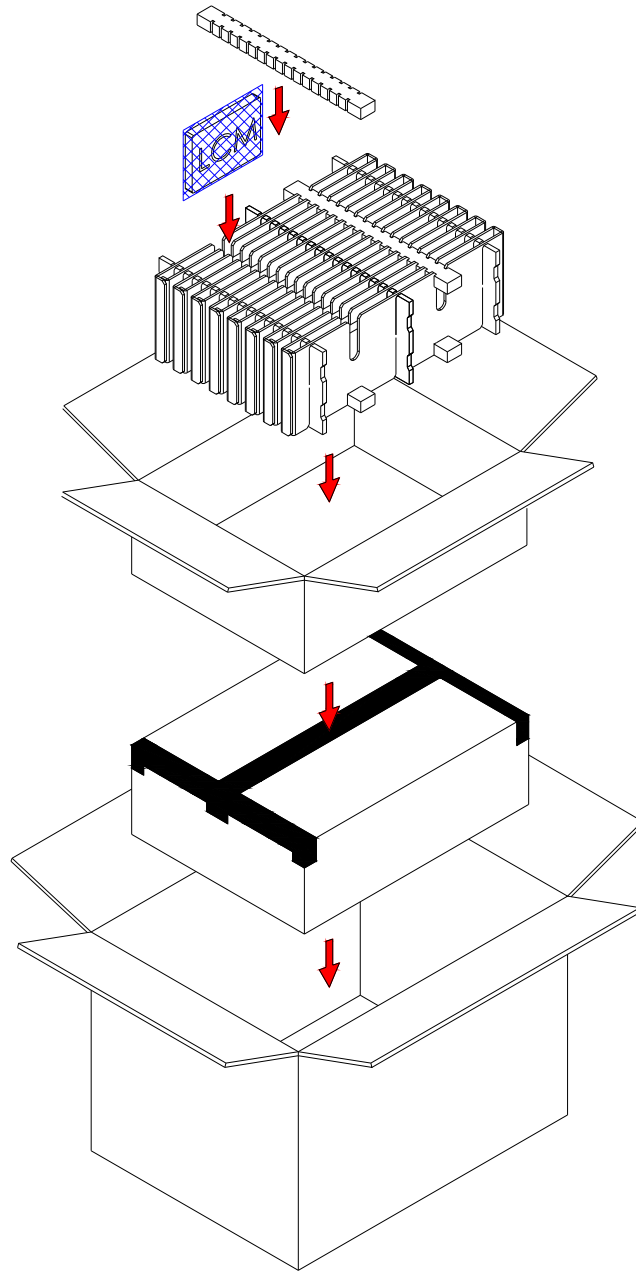

**PARTS LIST**

	ITEM	SIZE(LxWxH) unit:mm	MATERIAL	Q.T.Y	NOTE
1	STATIC SHIEDING BAGS	300.0×145.0×0.09		60	
2	EPE PAD	345.0×30.0×20.0	EPE	8	
3	CARD BOARD	345.0×150.0×3.5	CARTON	6	
4	CARD BOARD	450.0×23.0×150.0	CARTON	16	
5	INTERNAL BOX	455.0×350.0×164.0	CARTON	2	
6	EXTERNAL BOX	475.0×370.0×375.0	CARTON	1	
7	PRODUCT	125.5×67.2×8.15		60	

<b>EVERVISION</b>	<b>MODEL NO.</b>		<b>PAGE</b>
	VGG804830-0TSLWB	SPEC SAMPLE	22

## **15. Precautions**

### **15.1 Assembly and Handling Precautions**

- (1) Do not apply rough force such as bending or twisting to the module during assembly.
- (2) It's recommended to assemble or to install a module into the user's system in clean working areas. The dust and oil may cause electrical short or worsen the polarizer.
- (3) Don't apply pressure or impulse to the module to prevent the damage of LCD panel and Backlight.
- (4) Always follow the correct power-on sequence when the LCD module is turned on. This can prevent the damage and latch-up of the CMOS LSI chips.
- (5) Do not plug in or pull out the I/F connector while the module is in operation.
- (6) Do not disassemble the module.
- (7) Use a soft dry cloth without chemicals for cleaning, because the surface of polarizer is very soft and easily scratched.
- (8) Moisture can easily penetrate into LCD module and may cause the damage during operation.
- (9) High temperature or humidity may deteriorate the performance of LCD module. Please store LCD module in the specified storage conditions.
- (10) When ambient temperature is lower than 10°C, the display quality might be reduced. For example, the response time will become slow.

### **15.2 Safety Precautions**

- (1) If the liquid crystal material leaks from the panel, it should be kept away from the eyes or mouth. In case of contact with hands, skin or clothes, it has to be washed away thoroughly with soap.
- (2) After the module's end of life, it is not harmful in case of normal operation and storage.

### **15.3 Terms of Warrant**

- (1) Acceptance inspection period  
The period is within one month after the arrival of contracted commodity at the buyer's factory site.
- (2) Applicable warrant period  
The period is within twelve months since the date of shipping out under normal using and storage conditions.

### 15.4 Cautions for LCM's installing and assembling

Please keep away the FPC while assembling or fixing the LCM to avoid FPC being damaged or extruded or other related problems. Please see below picture.

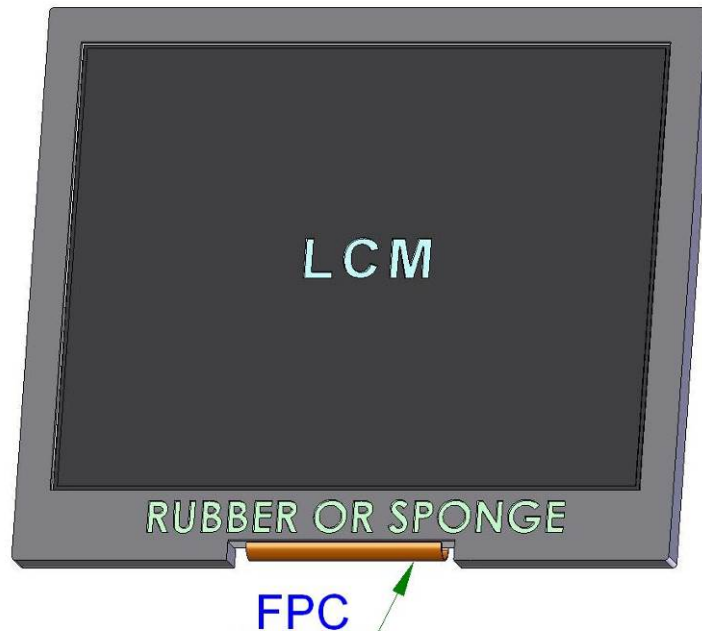

### 15.5 Caution

This Evervision LCD module has been specifically designed for use only in electronic devices in the areas of audio control, office automation, industrial control, home appliances, etc. The modules should not be used in applications where module failure could result in physical harm or loss of life, and Evervision expressly disclaims any and all liability relating in any way to the use of the module in such applications.

### 15.6 Precautions of Storage

If the displays are going to be stored for years, please be aware the following notices.

- (1) Please store the displays in a dark room to avoid any damages from sunlight and other sources of UV light.
- (2) The recommended long term storage temperature is between 10 ~35°C and <60% humidity to avoid causing bubbles between polarizer and LCD glasses, and polarizer peeling from LCD glasses.
- (3) It would be better to keep the displays in the container, which is shipped from Evervision, and do not unpack it.
- (4) Please do not stick any labels on the display surface for a long time, especially on the polarizer.





**17. Definition of Labels**

The bar code nameplate is pasted on each module as illustration, and its definitions are as following explanation.

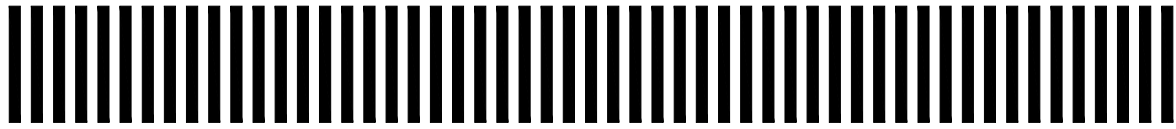

VGG804830-0TSLWB

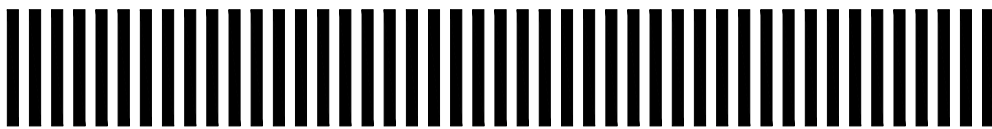

ABCDEFGHIJKL

(a) Module Name : VGG804830-0TSLWB

(b) Serial ID :

A B C D E F G H IJKL

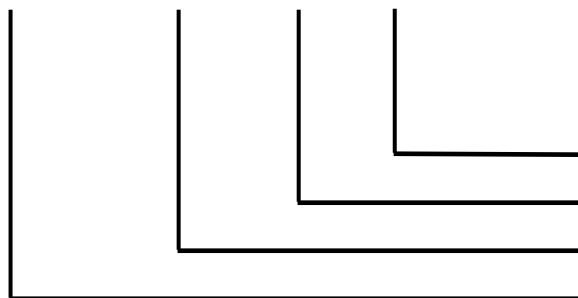

Serial No.  
 Factory Code  
 Manufactured Date  
 Screen Size

Serial ID includes the information as below :

(a) Screen size (Diagonal) : Inch Code (ABCD)

3.5" → 0350

10.4" → 1040

(b) Manufactured Date : Year, Month, Day (EFG)

**Year (E)**

Year	2000	2001	2002	2003	2004	2005	2006	2007	2008	2009
Mark	0	1	2	3	4	5	6	7	8	9
Year	2010	2011	2012	2013	2014	2015	2016	2017	2018	2019
Mark	A	B	C	D	E	F	G	H	I	J
Year	2020	2021	2022	2023	2024	2025	2026	2027	2028	2029
Mark	K	L	M	N	O	P	Q	R	S	T
Year	2030	2031	2032	2033	2034	2035				
Mark	U	V	W	X	Y	Z				

**Month (F)**

Month	Jan.	Feb.	Mar.	Apr.	May	Jun.	Jul.	Aug.	Sep.	Oct.	Nov.	Dec.
Mark	1	2	3	4	5	6	7	8	9	A	B	C

**Day (G)**

Day	1	2	3	4	5	6	7	8	9	10	11	12	13	14	15	16
Mark	1	2	3	4	5	6	7	8	9	A	B	C	D	E	F	G
Day	17	18	19	20	21	22	23	24	25	26	27	28	29	30	31	
Mark	H	I	J	K	L	M	N	O	P	Q	R	S	T	U	V	

(c) Factory Code (H) :

For EVERVISION internal use.

(d) Serial No. (IJKL) :

Manufacturing sequence of product, for example : 0001~9999.

## 18. Incoming Inspection Standards

### 1.The environmental condition of inspection

The environmental condition and visual inspection shall be conducted as below.

- (1) Ambient temperature  $25 \pm 5^{\circ}\text{C}$
- (2) Humidity: 45 ~ 65 % RH
- (3) Viewing distance is approximately 30 cm
- (4) Viewing angle is normal to the LCD panel as Fig \_1 ( $\pm 45^{\circ}$ )
- (5) Ambient Illumination: 300 ~ 500 Lux for external appearance inspection

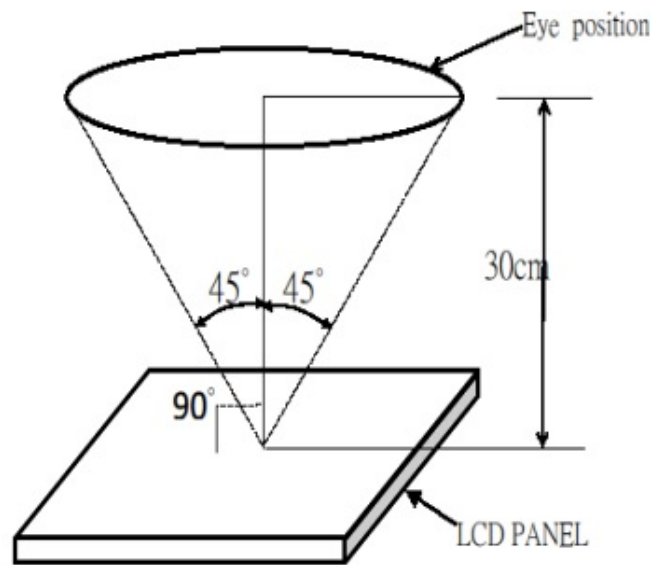

Fig\_1

### 2.The defects classify of AQL as following:



- (1) Test method: According to ANSI/ASQC Z 1.4 .General Inspection Level II take a single time
- (2) The defects classify of AQL as following:

Class of defects	AQL	Definition
Major	0.65%	It is defect that is likely to result in failure or to reduce materially the usability of the intended function.
Minor	1.5%	It is a defect that will not result in functioning problem with deviation classified.

<b>EVERVISION</b>	<b>MODEL NO.</b>		<b>PAGE</b>
	VGG804830-0TSLWB	SPEC SAMPLE	28

### 3 Inspection Parameters

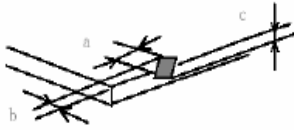
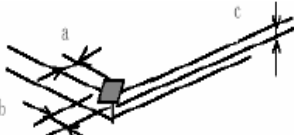
Item		Specification/Description			Note	
Display	Function	No Display			-	
		Malfunction			-	
Operating	Contrast ratio	Out of Spec			-	
	Line defect	No obvious Vertical and Horizontal line defect in bright , dark and colored.			-	
	Point Defect (red ,green ,blue ,dark ,white)	Item	Acceptable number			Note: 1、 4、 5、 6
			A	B	Total	
		BRIGHT DOT	$N \leq 1$	$N \leq 2$	$N \leq 6$	
		DARK DOT	$N \leq 2$	$N \leq 4$		
		TOTAL DOT	$N \leq 3$	$N \leq 4$		
		Distance between Bright - Bright	-			
Distance between Dark - Dark	$\geq 5\text{mm}$					
Distance between Bright - Dark	-					
External Inspection (non-operating or operating)	Scratch ( in display area)	L(mm)	W(mm)	Acceptable number	Note:2	
		$L \leq 2.5$	$W \leq 0.1$	3		
		$L > 2.5$	$W > 0.1$	0		
	Polarizer dent or bubble ( in display area)	Dimension(mm)		Acceptable number		Note:3
		$D \leq 0.25$		Disregard		
		$D \leq 0.5$		4		
	Line Shape (Particles and Lint in display area)	L(mm)	W(mm)	Acceptable number		Note:2
		-	$W \leq 0.07$	Disregard		
		$L \leq 5$	$W \leq 0.1$	4		
		$L \geq 5$	$W \geq 0.1$	0		
	Dot Shape (Particle in Display area)	Dimension(mm)		Acceptable number		Note:3
		$D \leq 0.25$		Disregard		
$D \leq 0.5$		4				

Item		Specification/Description			Note
Touch Panel	Scratch	L(mm)	W(mm)	Acceptable number	Note:2
		$L \leq 10$	$W < 0.05$	Disregard	
			$0.05 \leq W < 0.1$	$N \leq 4$	
	Foreign Materials (Linear shape)	$L \leq 10$	$W < 0.05$	Disregard	Note:2
			$0.05 \leq W < 0.1$	$N \leq 3$	
			$W \geq 0.1$	0	
	Foreign Materials (Circular shape)	Dimension(mm)		Acceptable number	Note:3
		$D \leq 0.25$		Disregard	
		$0.25 < D \leq 0.5$		$N \leq 6$	
	Glass chipping			$a \leq 5\text{mm}$ $b \leq 3\text{mm}$ $c \leq t$ (t : Glass think)	Note:7
		$a \leq 3\text{mm}$ $b \leq 3\text{mm}$ $c \leq t$ (t : Glass think)	Note:7		
Newton-ring	(In case of doubtful situations) Observe on $60^\circ$ from the product surface under a white Fluorescent lamp (3-wavelength lamp).		Average diameter $\leq 1/3$ Touch Panel area Disregard.	Note:7	
Membrane Drum			$H \leq 0.35\text{mm}$	-	

Note1. The definition of dot defect : The dot defect was judged after repair and the size of a defective dot over 1/2 of whole dot is regarded as one defective dot.

Note2.

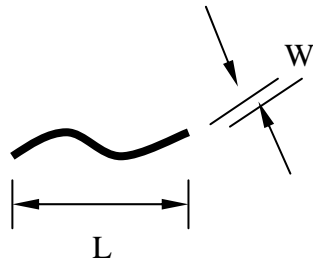

Note3. D : Diameter  $D=(a+b)/2$

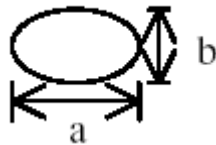

Note4. Bright dot, mura and leak are defined through transmission ND Filter as following.

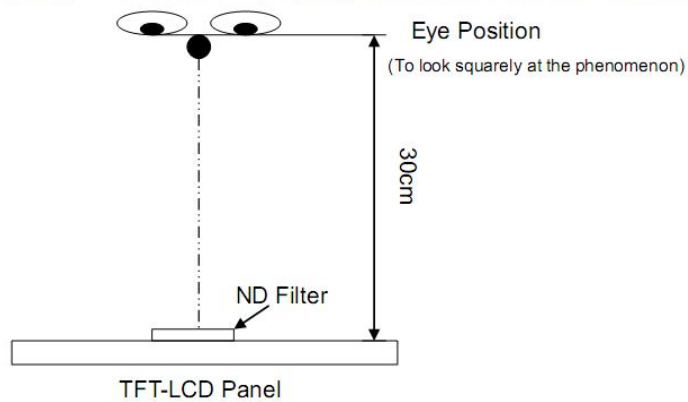

Note5. Minimum distance between dot defects

-Dark dot to Dark dot

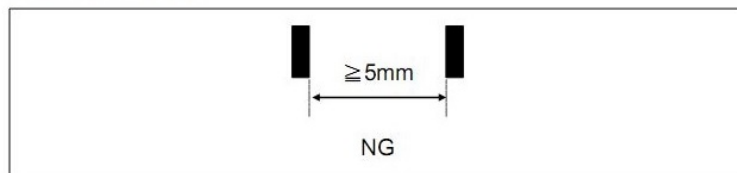

- Bright dot to Dark dot

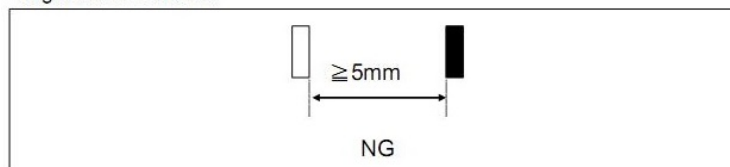

Note6.

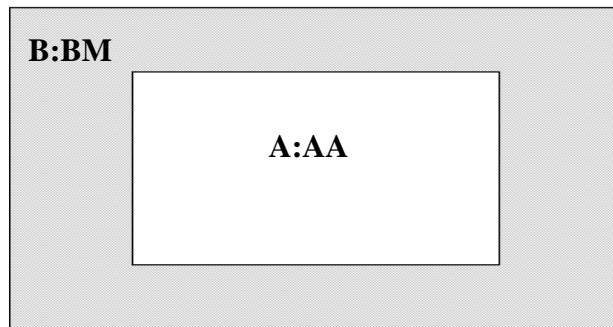

### 18.5 Handling of LCM

- (1) Don't give external shock.
- (2) Don't apply excessive force on the surface.
- (3) Liquid in LCD is hazardous substance. Must not lick and swallow. when the liquid is attach to your hand, skin, cloth etc. Wash it out thoroughly and immediately.
- (4) Don't operate it above the absolute maximum rating.
- (5) Don't disassemble the LCM.