



# HITPOINT

TEL:8862-26013311

FAX:8862-26013898

NO.4 Lane 505, Zhongzheng Rd., Linkou Shiang, Taipei, Taiwan 24445 . R.O.C

## Piezo Electric Buzzer PF-35A29EPD-24VQ

(RoHS)

DATE:2010.05.17

### 1 . Electrical Characteristics

VER .:6

Oscillation Frequency (KHz)	2.9 ±0.5
Operating Voltage (Vdc/ac)	6 ~ 28
Rated Voltage (Vdc/ac)	24
Current Consumption (mA/max.)	20 at Rated Voltage
Sound Pressure Level (dB/min.)	90 at 30cm at Rated Voltage
Tone/Pulse Rate (Hz)	Fast Pulse 3.0 ±20% at Rated Voltage
Operating Temperature ( °C)	-20 ~ +70
Storage Temperature ( °C)	-30 ~ +80

### 2 . Voltage/ Current / Sound Pressure

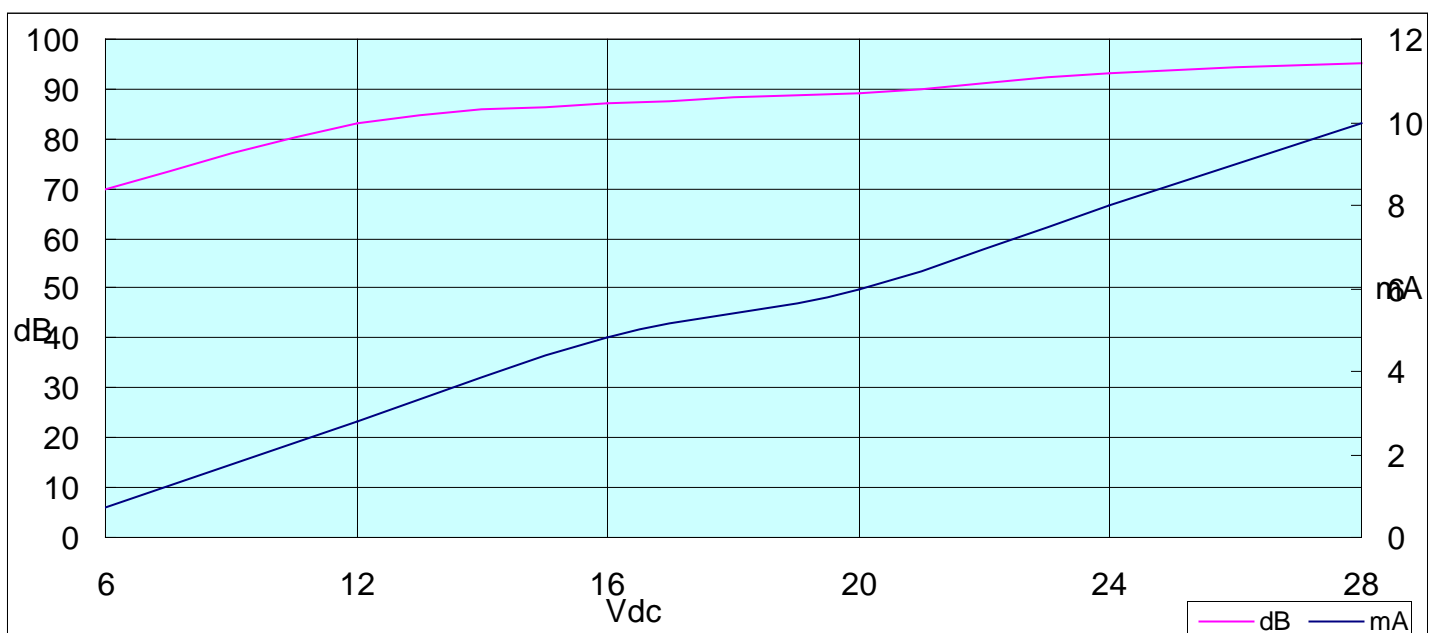



# HITPOINT

TEL:8862-26013311

FAX:8862-26013898

NO.4 Lane 505, Zhongzheng Rd., Linkou Shiang, Taipei, Taiwan 24445 . R.O.C

### 3 . Dimensions and Material

#### 3-1 Shape

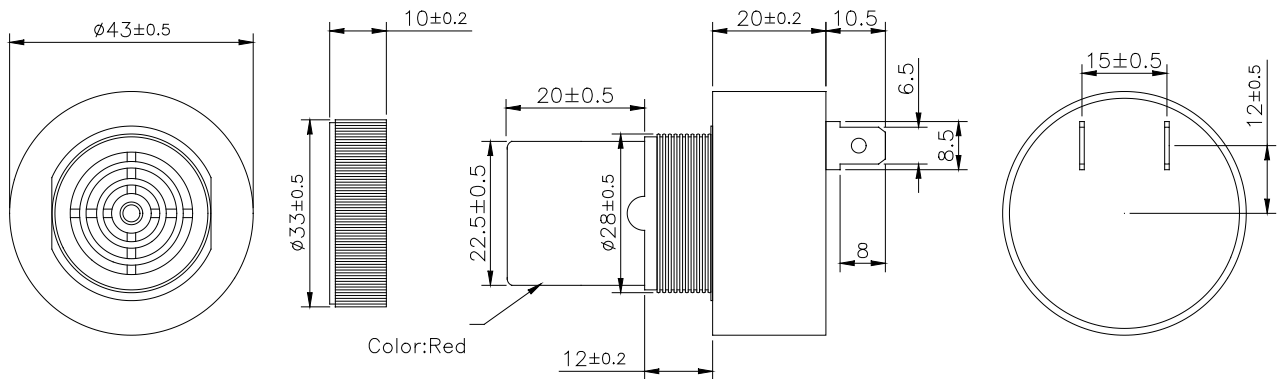

Unit : mm

#### 3-2 Material

Housing	ABS 757 UL94HB plastic resin (Color : Black)
Leading Pin	Tin Plated Brass
Weight (Gram)	43.8



# HITPOINT

TEL:8862-26013311  
FAX:8862-26013898

NO.4 Lane 505, Zhongzheng Rd., Linkou Shiang, Taipei, Taiwan 24445 . R.O.C

## 4. TESTING METHOD

### · *Standard Measurement conditions*

Temperature:  $25 \pm 2^\circ\text{C}$  Humidity: 45-60%

### · *Acoustic Characteristics*

The oscillation frequency, current consumption and sound pressure are measured by the measuring instruments shown below.

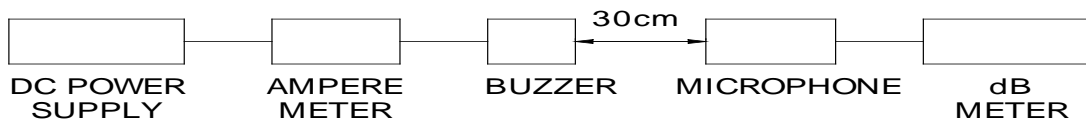

## 5. RELIABILITY

<b>ITEMS</b>	<b>METHOD OF TEST AND MEASUREMENTS</b>	<b>PERFORMANCE</b>
<i>Coldness withstanding</i>	<i>After 98 hours of being exposed to <math>-30^\circ\text{C}</math> environment, should be returned to normal environment for 2 hours, then re-proceed to test.</i>	<i>No abnormality shall exist</i>
<i>Hotness withstanding</i>	<i>After 98 hours of being exposed to <math>+80^\circ\text{C}</math> environment, should be returned to normal environment for 2 hours, then re-proceed to test.</i>	<i>No abnormality shall exist</i>
<i>Humidity withstanding</i>	<i>After 98 hours of being exposed to <math>40^\circ\text{C}</math> 95%RH environment in actual operation, should be returned to normal environment for 2 hours, then re-proceed to test.</i>	<i>No abnormality shall exist</i>
<i>Durability</i>	<i>Testing after 1,000 hours actual continuous operation.(at standard measurement conditions)</i>	<i>No abnormality shall exist</i>
<i>Drop withstanding</i>	<i>A natural drop from 75cm high down to the ground.</i>	<i>No abnormality shall exist</i>
<i>Vibration withstanding</i>	<i>Vibration of 2,000 cycles per minute, 2mm amplitude, applied in X, Y and Z directions for 30 minutes each.</i>	<i>No abnormality shall exist</i>



# HITPOINT

TEL:8862-26013311

FAX:8862-26013898

NO.4 Lane 505, Zhongzheng Rd., Linkou Shiang, Taipei, Taiwan 24445 . R.O.C

## **6. PACKAGE METHOD**

<1> 28pcs per box , Total 10 boxes per carton , total 280pcs carton;

Volume: L\*W\*H=520\*335\*290mm

<2>N . W . : 12.3KGS ; G . W . : 14..3KGS ;

<3> RoHS Mark: