



Elektrotechnik Karl-Heinz Mauz GmbH

LSM-S19K (Artikel-Nr. 130006)

EKULIT

SPECIFICATIONS:

TYPE	UNIT	LSM-S19K
Impedance	Ω	$8 \pm 15\%$
Power (Nominal)	W	1.0
Power (Maximum)	W	2.0
Resonant Frequency	Hz	$500 \pm 20\%$
Sound Pressure Level	dB	87 ± 3
Frequency Range	Hz	Fo~20.000
Operating Temperature	$^{\circ}\text{C}$	-20~+60
Storage Temperature	$^{\circ}\text{C}$	-30~+70

DIMENSIONS :

(Unit: mm)

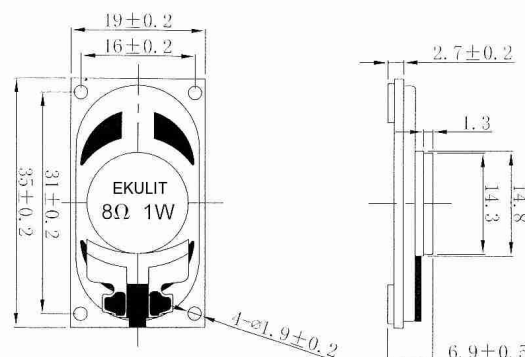

Frequency response:

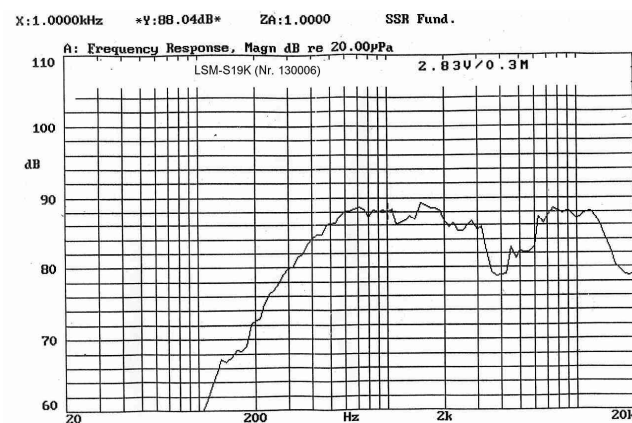

Adresse: Felix-Wankel-Str. 35 • 73760 Ostfildern/Nellingen

Tel: +49-711/3414023

Fax: +49-711/3414024

E-mail: info@ekulit.de Web site: www.EKULIT.de