

CARD GUIDES ARE NOT
DETAILED IN SIDE VIEWS

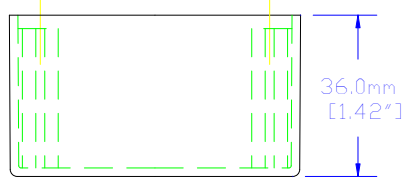
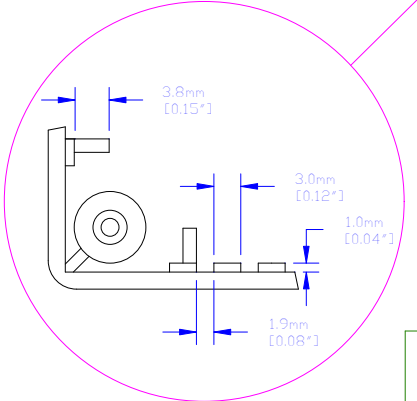

BOX

THIS DRAWING IS PROPRIETARY INFORMATION
OF HAMMOND MFG.CO.LTD. NOT TO BE USED
WITHOUT EXPRESSED WRITTEN PERMISSION
OF HAMMOND MFG.CO.LTD.

△	N/A	RELEASE	----	12/27/02	MJM
Rev	ECN	Description		Date	B

NOTES

MATERIAL: (ABS) FLAME RETARDANT UL94 V0 (FILE # E56070) MATERIAL WITH BRASS INSERTS IN CORNER POSTS. (STYRENE) IS NON-FLAME RETARDANT WITHOUT BRASS INSERTS.
 SCREWS: (ABS) MACHINE SCREWS M3-0.5 × 10mm. REPLACEMENT PN 1591MS100 (100/BAG). (STYRENE) SELF TAPPING #4 × 0.5". REPLACEMENT PN 1599TS100BK (100/BAG).
 COLORS: ** (ABS) BLACK, GRAY, BLUE, & BEIGE, (STYRENE) BLACK ONLY.
 STANDARD OPTIONS: SHIELDED, FLANGED BOTTOM, FLANGED LID

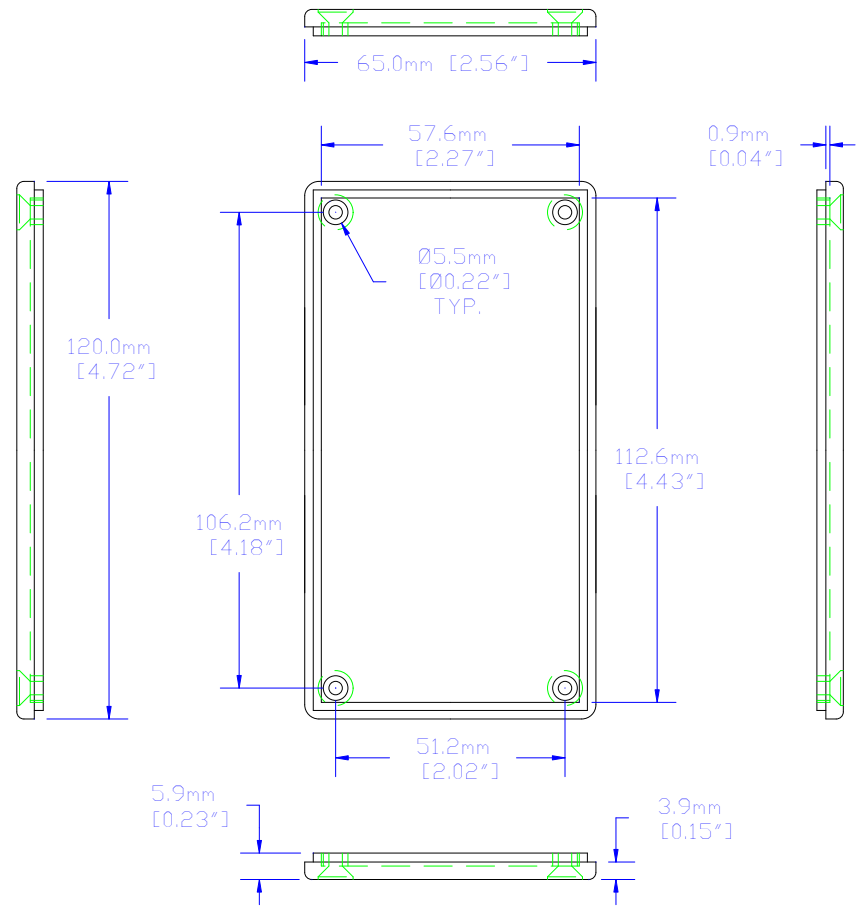

LID

For the best fit print
on legal size paper.

Unless otherwise spec'd dimensions are in millimeters Tolerances are: .X ±0.5 .XX ±0.25 .XXX ±0.130 Holes ±0.130 Angles ±5°	Dwn	M. MERCER
	Date	12/27/02
	Chk	---
	Mat'l	SEE NOTES
Sheet	1 of 1	

HAMMOND MANUFACTURING CO. LTD. Electronics Group, Waterloo, Ont. - Cheektowaga, NY	
HAMMOND 1591 SERIES PLASTIC ENCLOSURE	
Part#: 1591C**	Dwg: 1591C/A