



# Elektrotechnik Karl-Heinz Mauz GmbH

**EMB 10-15** (Artikel-Nr. 195035)

**EKULIT**

## *SPECIFICATIONS:*

TYPE	UNIT	EMB 10-15
• Sound Output at 10cm	dB	75±5
Rated Voltage	V <sub>AC</sub>	220
Operating Voltage	V <sub>AC</sub>	150~250
Oscillation Frequency	Hz	50~60
• Current Consumption max.	mA	25
Coil Resistance	Ω	8000±10%
Tone nature		Continuous
Operating Temperature	°C	-30~+70
Housing Material		PPO (Red)
Leading Pin		Plating (Ni)
Storage Temperature	°C	-40~+80
Weight	g	20

## DIMENSIONS :

(Unit: mm)

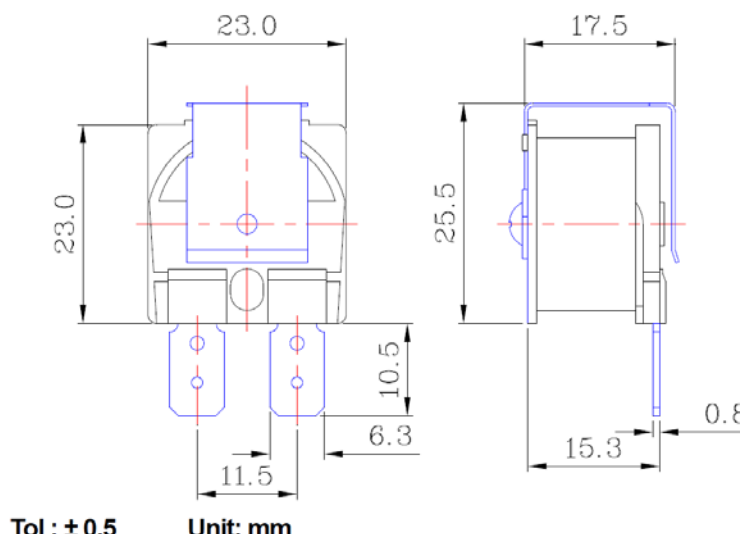

Adresse: **Felix-Wankel-Str. 35 • 73760 Ostfildern/Nellingen**

Tel: **+49-711/3414023**      Fax: **+49-711/3414024**

E-mail: **info@ekulit.de**      Web site: **www.EKULIT.de**

### Testing Method:

#### Standard Measurement conditions

Temperature:  $25 \pm 2^\circ\text{C}$  Humidity: 45-65%

#### Acoustic Characteristics:

The oscillation frequency, current consumption and sound pressure are measured by the measuring instruments shown below

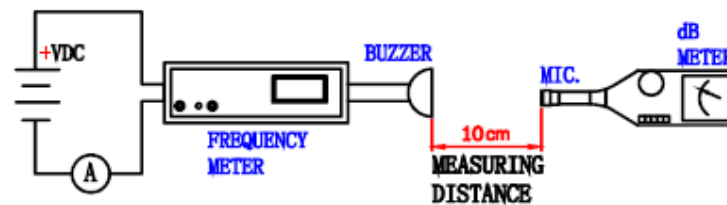

In the measuring test, buzzer is placed as follows:

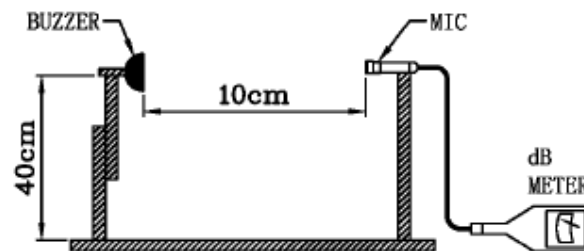

### E. VOLTAGE / CURRENT / SOUND PRESSURE CHARACTERISTICS

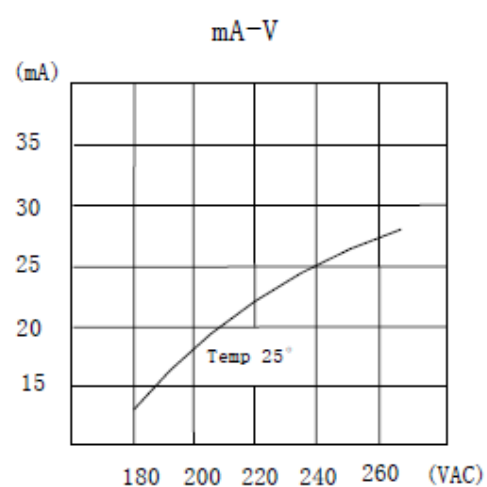
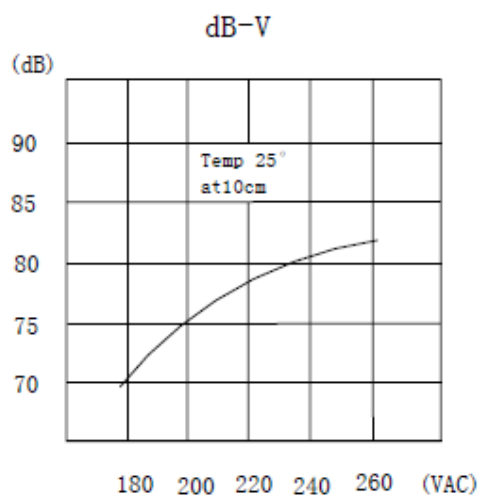



# Elektrotechnik Karl-Heinz Mauz GmbH

## EKULIT

### Reloability Test:

NO.	ITEM	TEST CONDITION AND REQUIREMENT
1	High Temperature Test (Storage)	After being placed in a chamber with $80\pm 2^{\circ}\text{C}$ for 96 hours and then being placed in normal condition for 2 hours. Allowable variation of SPL after test: $\pm 10\text{dB}$ .
2	Low Temperature Test (Storage)	After being Placed in a chamber with $-40\pm 2^{\circ}\text{C}$ for 96 hours and then being placed in normal condition for 2 hours. Allowable variation of SPL after test: $\pm 10\text{dB}$ .
3	Humidity Test	After being Placed in a chamber with 90-95% R.H. at $40\pm 2^{\circ}\text{C}$ for 96 hours and then being placed in normal condition for 2 hours. Allowable variation of SPL after test: $\pm 10\text{dB}$ .
4	Temperature Cycle Test	<p>The part shall be subjected to 5 cycles. One cycle shall be consist of :</p> <p>Allowable variation of SPL after test: <math>\pm 10\text{dB}</math>.</p>
5	Drop Test	Drop on a hard wood board of 4cm thick, any directions ,6 times, at the height of 75cm. Allowable variation of SPL after test: $\pm 10\text{dB}$ .
6	Vibration Test	After being applied vibration of amplitude of 1.5mm with 10 to 55 Hz band of vibration frequency to each of 3 perpendicular directions for 2 hours. Allowable variation of SPL after test: $\pm 10\text{dB}$ .
7	Solderability Test	Lead terminals are immersed in rosin for 5 seconds and then immersed in solder bath of $+300\pm 5^{\circ}\text{C}$ for $3\pm 1$ seconds . 90% min. lead terminals shall be wet with solder (Except the edge of terminals).
8	Terminal Strength Pulling Test	The force of 9.8N(1.0kg) is applied to each terminal in axial direction for 10 seconds. No visible damage and cutting off.

#### TEST CONDITION.

Standard Test Condition	:	a) Temperature : $+5 \sim +35^{\circ}\text{C}$	b) Humidity : 45-85%	c) Pressure : 860-1060mbar
一般测试条件	:	a) 温度 : $+5 \sim +35^{\circ}\text{C}$	b) 湿度 : 45-85%	c) 气压 : 860-1060mbar
Judgment Test Condition	:	a) Temperature : $+25 \pm 2^{\circ}\text{C}$	b) Humidity : 60-70%	c) Pressure : 860-1060mbar
争议时测试条件	:	a) 温度 : $+25 \pm 2^{\circ}\text{C}$	b) 湿度 : 60-70%	c) 气压 : 860-1060mbar

Adresse: Felix-Wankel-Str. 35 • 73760 Ostfildern/Nellingen

Tel: +49-711/3414023

Fax: +49-711/3414024

E-mail: [info@ekulit.de](mailto:info@ekulit.de) Web site: [www.EKULIT.de](http://www.EKULIT.de)