

NO MERCURY ADDED

Description : Lithium Battery, 9V Size
Chemical System : Lithium Manganese Dioxide
Nominal Voltage : 9 Volts
Nominal Capacity : 800mAh @ 600Ω to 5.4V
Nominal Dimensions : 26 mm x 16.5 mm x 44.7 mm
Terminals : Standard snap fastener stud(+) and socket(-)

Average Weight : App. 34grams

Application : Smoke detectors, security devices, medical equipment, carbon monoxide alarms, explosion gas alarms, meters (gas/electric/water), metal detectors, wireless transmitters, electronic toll collection system, etc.

Operating temperature : -40°C to 60°C

Cross References:

ANSI	Ultralife
1604LC	U9VL

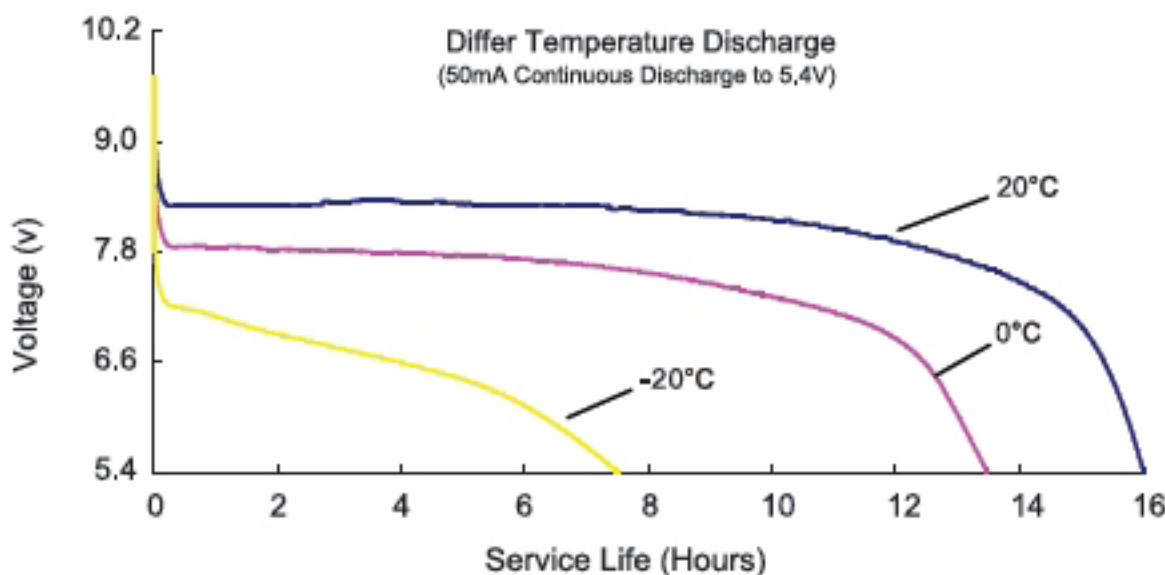
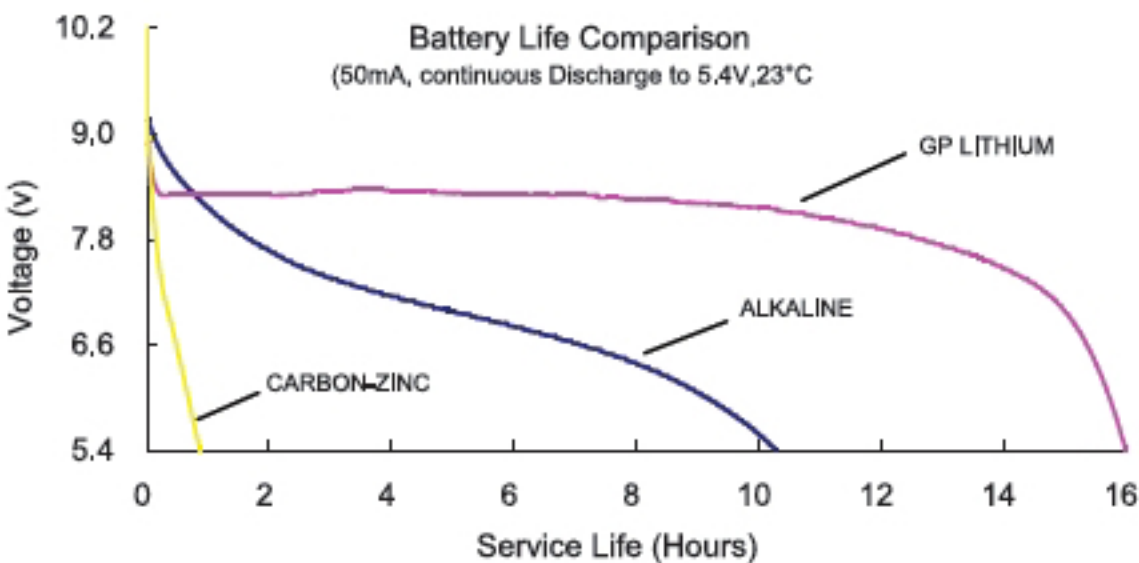

www.gpbatteries.com

Manufacturer reserves the right to alter or amend the design, model and specification without prior notice.
 Copyright© GPI International Ltd. - All rights reserved

Model No.: **GPCR-V9**

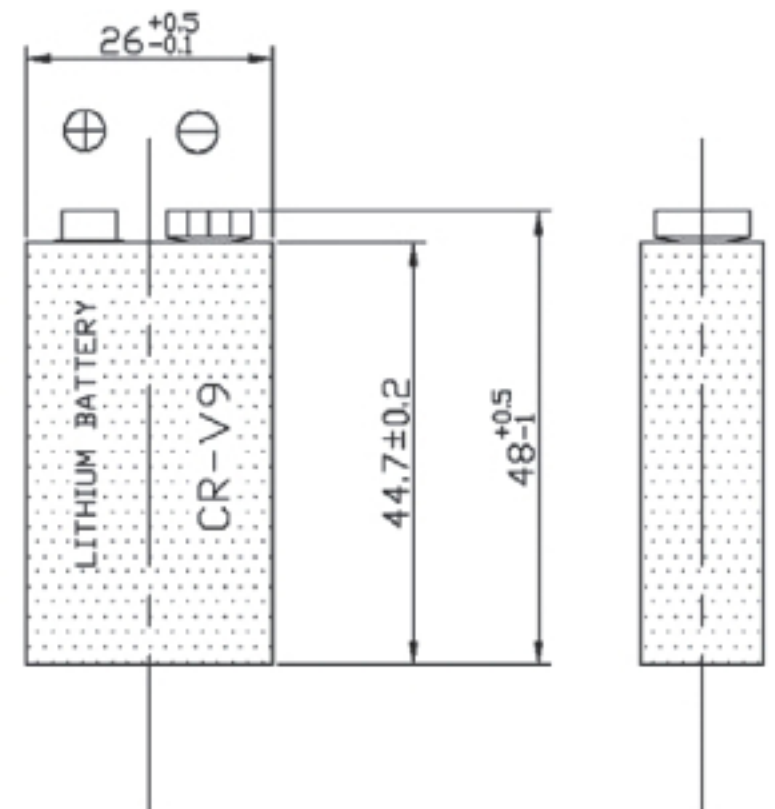
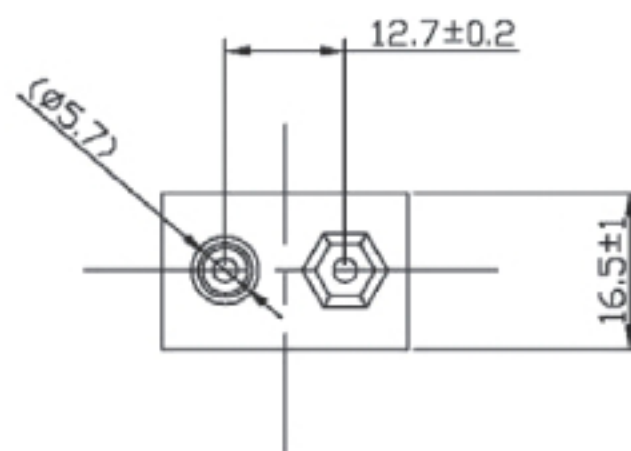

Unit : mm

The information (subject to change without prior notice) contained in this document is for reference only and should not be used as a basis for product guarantee or warranty. For applications other than those described here, please consult your nearest GP Sales and Marketing Office or Distributors.