

24 Bit RGB, 8/16-bit parallel, SPI interface



*Dimension 52x36x2.2mm
65x43x4.2mm (incl. PCAP)*

FEATURES

- 2.0" TFT FULL COLOR
- AACS TECHNOLOGY WITH IPS FOR UNLIMITED VIEWING ANGLE
- 240x320x3 DOTS, CONTROLLER ST7789V
- 800 or 640cd/m² WITHOUT/WITH TOUCHPANEL
- 24-BIT RGB INTERFACE
- 8/16-BIT PARALLEL INTERFACE
- SPI INTERFACE
- INTEGRATED CONTROLLER ST7789V
- SINGLE SUPPLY 3.3V
- WIDE TEMPERATURE RANGE (T_{OP} -20°C - +60°C)
- OPTIONALLY WITH PCAP AND CONTROLLER GT911

ORDERING CODES

- 2.0" TFT, 240x320 IPS, 800cd/m²
- AS ABOVE BUT WITH OPTICALLY BONDED PCAP

EA TFT020-23AINN
EA TFT020-23AITC

ACCESSORY

- ZIF CONNECTOR 0.3MM, BOTTOM CONTACT

EA WF030-39S

CONTENT

Revision History.....	3
2.0" TFT display.....	3
Accessory	3
Absolute Maximum Ratings	4
Electrical Specification.....	5
TFT Panel	5
LED Backlight.....	5
PCAP TOUCHPANEL (EA TFT020-23AITC only).....	6
Optical Specifications	6
Measurement System	7
Block Diagram	9
Pin Description.....	10
Timing Characteristics (Details refer to ST7789V)	11
8080 Series Parallel interface characteristics:18/16/9/8-bit bus	11
Serial interface characteristics (4-line serial)	12
RGB interface characteristics.....	13
Reset Timing	14
Reliability and Inspection Standard	15
PRECAUTIONS FOR USING LCD MODULES.....	16
Handling Precautions.....	18
Storage Precautions.....	19
Others	19
Outline Dimension	20

REVISION HISTORY

	Rev.	Page	Description
2018-12-10	1.0	All	First issue

2.0" TFT DISPLAY

With its new 2.0" TFT displays ELECTRONIC ASSEMBLY launches worldwide the first smaller size displays with high-quality. With its IPS technology these displays provide full viewing angle with all-angle color stability management (AACs). This means that color stays same even when viewing angle is changing.

Display brightness is enormous with 640~800cd/m² and make the displays readable even at direct sunlight. Displays providing many interface modes like standard RGB interface which is suitable even for fast changing display content. The 4-wire SPI interface is perfect for pin saving applications and the 16-bit μ C data bus interface enables parallel access to the display.

The version EA TFT020-23AITC comes with an optical bonded (OCA) PCAP touch panel. Interface is I²C which makes it easy to read out directly the coordinates.

Connection is simple with a single FPC cable for 39-pin ZIFF connection.

ACCESSORY

The **EA WF030-39S** is the relating ZIF connector for easy and safe connection. Providing connection all in one for:

- Power supply
- TFT Display
- Backlight
- PCAP

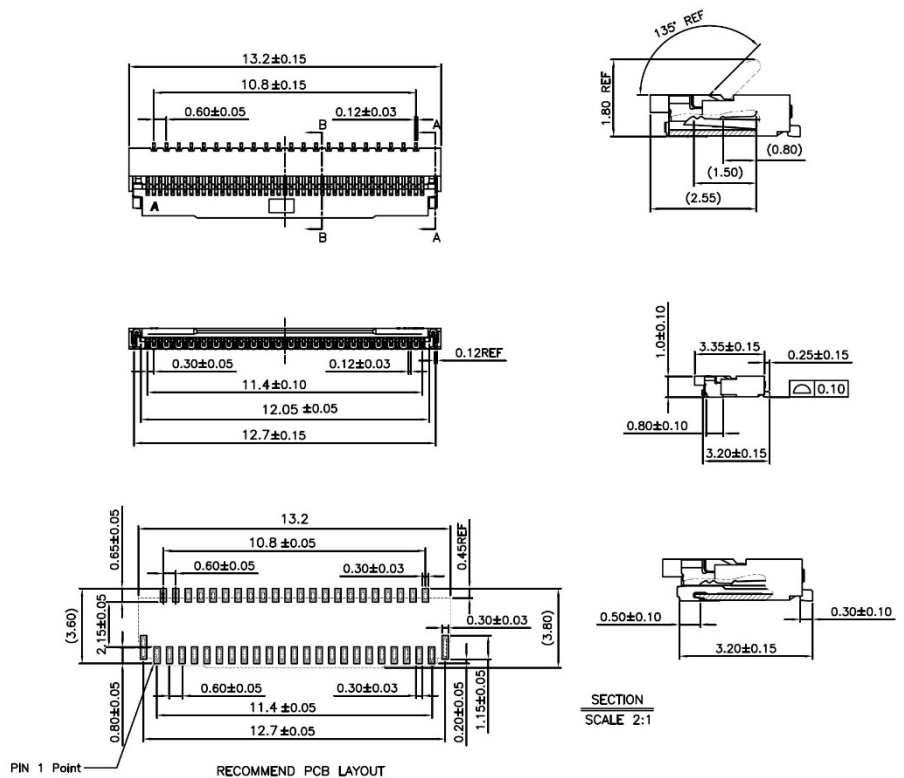

ABSOLUTE MAXIMUM RATINGS

The following are maximum values which, if exceeded may cause operation or damage to the unit.

Item	Symbol	Min.	Typ.	Max.	Unit	Remark
Power for Circuit Driving	V _{CC}	-0.3	-	4.6	V	
Power for Circuit Logic	V _t	-0.3	-	V _{CC} +0.3	V	
Storage Humidity	H _{ST}	10	-		%RH	At 25±5°C
Storage Temperature	T _{ST}	-30	-	70	□	
Operating Ambient Humidity	H _{OP}	10	-		%RH	
Operating Ambient temperature	T _{OP}	-20	-	60	□	

For more detailed information please refer to the data sheet for ST7789V at

<http://www.lcd-module.de/fileadmin/html-seiten/eng/pdf/zubehoer/ST7789V.pdf>

ELECTRICAL SPECIFICATION

TFT PANEL

Item		Symbol	Min	Typ.	Max	Unit	Note
Power for Circuit Driving		VDD	2.5	2.8	3.6	V	
Power For Circuit Logic		VDDI	1.65	1.8	3.6	V	
Logic Input Voltage	Low Voltage	VIL	-0.3	-	0.2VDD	V	
	High Voltage	VIH	0.8VDD	-	VDD	V	
Logic Output Voltage	Low Voltage	VOL	0	-	0.2VDD	V	
	High Voltage	VOH	0.8VDD	-	-	V	
Power Consumption	Black Mode	P _b	T.B.D	T.B.D	T.B.D	mW	
	Standby Mode	P _w	T.B.D	T.B.D	T.B.D	mW	

LED BACKLIGHT

Item	Symbol	Min	Typ.	Max	Unit	Note
Backlight driving voltage	VF	23.2	24.0	24.8	V	
Backlight driving current	IF	20	20	25	mA	
Backlight Power Consumption	WBL	-	480	-	mW	
Life Time	-	-	30,000	-		Note 3

Note 1: (Unless specified, the ambient temperature Ta=25 °C)

Note 2: The recommended operating conditions refer to a range in which operation of this product is guaranteed. Should this range is exceeded, the operation cannot be guaranteed even if the values may be without the absolute maximum ratings.

Note 3: If LED is driven by high current, high ambient temperature & humidity condition. The life time of LED will be reduced. Operating life means brightness goes down to 50% initial brightness. Typical operating life time is estimated data.

PCAP TOUCHPANEL (EA TFT020-23AITC ONLY)

Item	Value
Power Supply Voltage	3.3V
Interface	I ² C
Support Touch	5 Points

OPTICAL SPECIFICATIONS

Optical characteristics are determined after the unit has been 'ON' and stable for approximately 30 minutes in a dark environment at 25 °C. The values specified are at an approximate distance 500mm from the LCD surface at a viewing angle of Φ and θ equal to 0°.

Item	Symbol	Value			Unit	Note
		Min.	Typ.	Max.		
1) Contrast Ratio	C/R	640	800	-		FIG.1
2) Module Luminance	L		800		cd/m ²	EA TFT020-23AINN
		520	640	-		EA TFT020-23AITC
3) Response time	T _r +T _f	-	30	-	ms	FIG.2
4) Viewing Angle	θ_T	-	80	-	Degree	FIG.3
	θ_B	-	80	-		
	θ_L	-	80	-		
	θ_R	-	80	-		
5) Chromaticity	W _x	0.276	0.296	0.316		
	W _y	0.305	0.325	0.345		
	R _x	-	-	-		
	R _y		-	-		
	G _x	-	-	-		
	G _y	-	-	-		
	B _x	-	-	-		
	B _y	-	-	-		

MEASUREMENT SYSTEM

1. Contrast Ratio(CR) is defined mathematically as :

$$\text{Contrast Ratio} = \frac{\text{Surface Luminance with all white pixels}}{\text{Surface Luminance with all black pixels}}$$

2. Surface luminance is the center point across the LCD surface 500mm from the surface with all pixels displaying white. For more information see FIG 1.

3. Response time is the time required for the display to transition from white to black (Rising Time, Tr) and from black to white (Falling Time, Tf). For additional information see FIG 2.

4. Viewing angle is the angle at which the contrast ratio is greater than 10. The angles are determined for the horizontal or x axis and the vertical or y axis with respect to the z axis which is normal to the LCD surface. For more information see FIG 3.

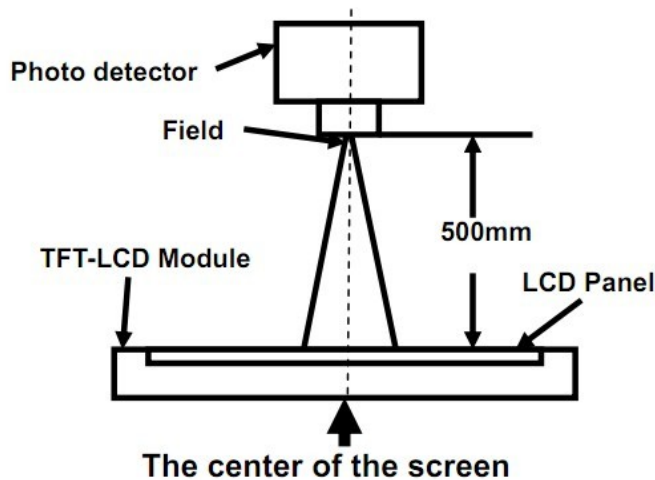

Item	Photo detector	Field
Contrast Ratio	SR-3A	1°
Luminance		
Chromaticity		
Lum Uniformity	BM-7A	2°
Response Time		

FIG. 1 Optical Characteristic Measurement Equipment and Method

The response time is defined as the following figure and shall be measured by switching the input signal for “black” and “white”.

Response Time = Rising Time(T_r) + Falling Time(T_f)

- Rising Time(T_r) : Full White 90% → Full White 10% Transmittance.
- Falling Time(T_f) : Full White 10% → Full White 90% Transmittance.

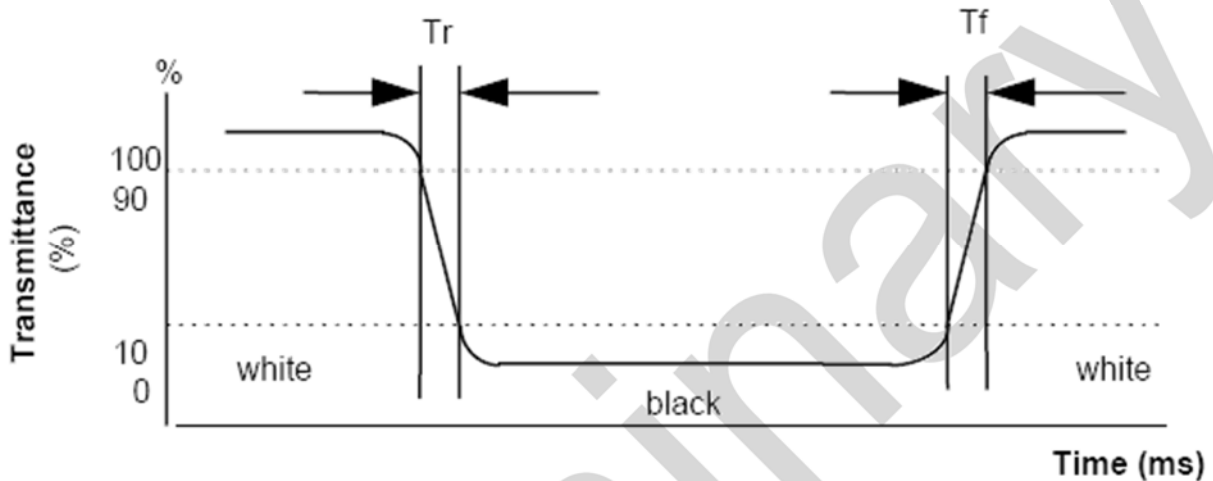

FIG. 2 The definition of Response Time

Use Fig. 1 (Test Procedure) under Measurement System to measure the contrast from the measuring direction specified by the conditions as the following figure.

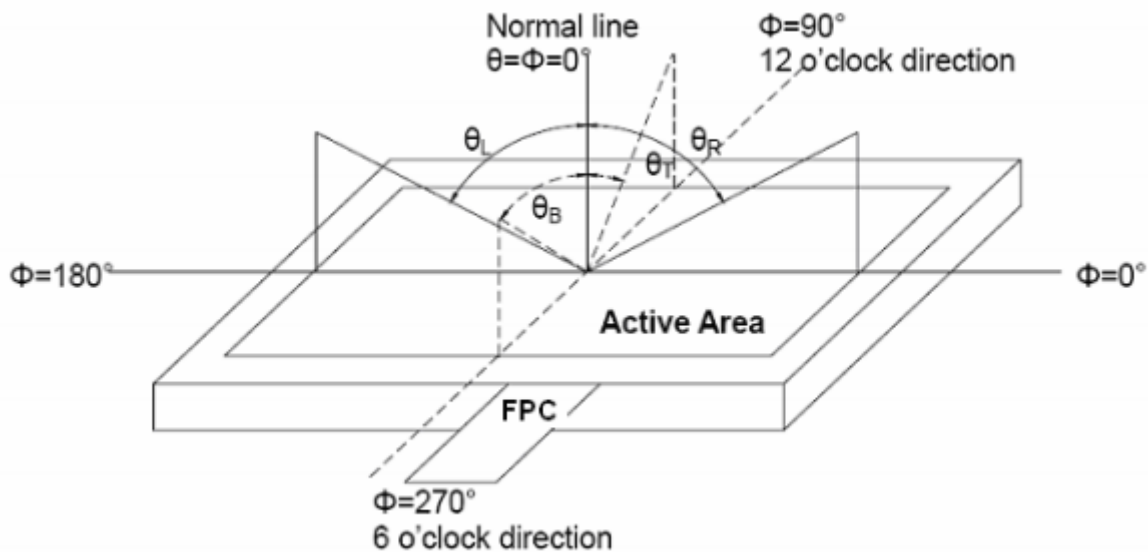
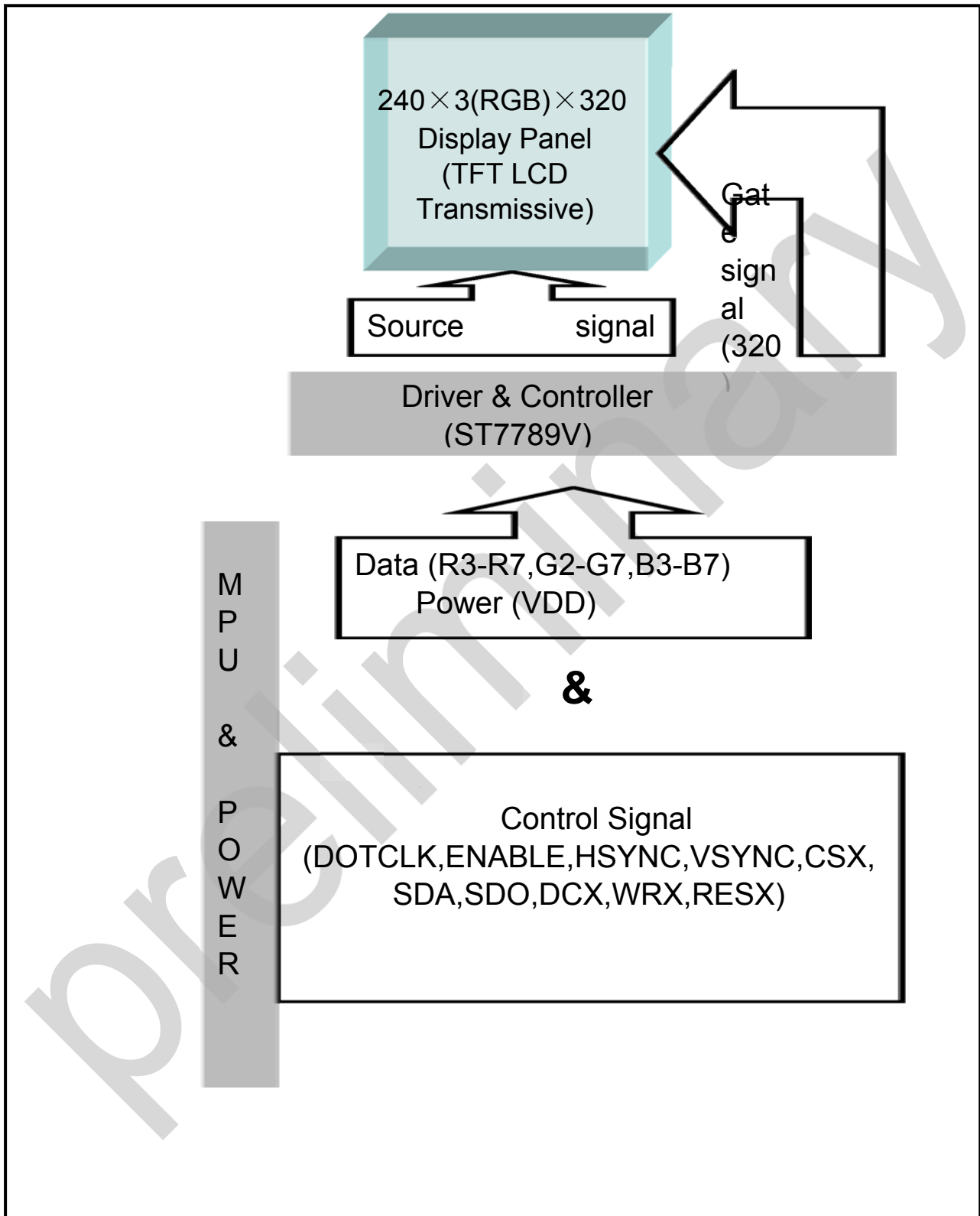

FIG. 3 The definition of Viewing Angle

BLOCK DIAGRAM



PIN DESCRIPTION

Pin	Symbol	Selected interface (Function)				Comment
		RGB	8-Bit	16-Bit	SPI	
1	LED-	LED-	LED-	LED-	LED-	LED cathode
2	LED+	LED+	LED+	LED+	LED+	LED anode (typ. 24V)
3	VDD+Touch VDD	VDD	VDD	VDD	VDD	Power input
4	GND+Touch GND	GND	GND	GND	GND	Ground
5	DB0	GND	D0	GND	GND	Data bus
6	DB1	B3	D1	D0	GND	Data bus
7	DB2	B4	D2	D1	GND	Data bus
8	DB3	B5	D3	D2	GND	Data bus
9	DB4	B6	D4	D3	GND	Data bus
10	DB5	B7	D5	D4	GND	Data bus
11	DB6	G2	D6	D5	GND	Data bus
12	DB7	G3	D7	D6	GND	Data bus
13	DB8	G4	GND	D7	GND	Data bus
14	DB9	G5	GND	GND	GND	Data bus
15	DB10	G6	GND	D8	GND	Data bus
16	DB11	G7	GND	D9	GND	Data bus
17	DB12	GND	GND	D10	GND	Data bus
18	DB13	R3	GND	D11	GND	Data bus
19	DB14	R4	GND	D12	GND	Data bus
20	DB15	R5	GND	D13	GND	Data bus
21	DB16	R6	GND	D14	GND	Data bus
22	DB17	R7	GND	D15	GND	Data bus
23	DOTCLK	DOTCLK	GND	GND	GND	Clock signal for RGB interface
24	ENABLE	DE	GND	GND	GND	Data enable signal for RGB interface
25	HSYNC	HSYNC	GND	GND	GND	Horizontal synchronizing
26	VSYNC	VSYNC	GND	GND	GND	Vertical synchronizing
27	TE	DNC	TE	TE	DNC	Tearing effect
28	CSX	DNC	CS	CS	CS	L: Chip select for serial interface
29	SDA	SDA	GND	GND	SDA	Serial data in
30	SDO	SDO	GND	GND	SDO	Serial data out
31	DCX	SCL	D/C	D/C	SCL	L: command, H: data /Clock signal for serial interface
32	WRX	D/C	WR	WR	D/C	L: Write enable or L:Command H: Data select pin
33	RESET	RESET	RESET	RESET	RESET	L: Reset for display and touchpanel controller
34	IM1+IM2	VDD	GND	GND	VDD	Interface Mode 1 and 2
35	IM3	VDD	GND	VDD	VDD	Interface Mode 3
36	RDX	GND	RD	RD	GND	L: Read Enable
37	Touch CLK	CLK	CLK	CLK	CLK	Touch serial clock signal
38	Touch SDA	SDA	SDA	SDA	SDA	Touch serial data signal
39	Touch INT	INT	INT	INT	INT	H: Interrupt output

Note 1: RGB mode: B2~B2 internally connected to B7, G0 and G1 internally connected to G7, R0~R2 internally connected to R7

IM3	IM1+IM2	Interface Mode	Data Pins
0	0	Z80 8 Bit parallel	DB[7:0]
0	1	SPI 4 line 8 Bit serial I/F	SDA: in/out
1	0	Z80 16 Bit parallel I/F II	DB[17:10] DB[8:1]
1	1	SPI 4 line 8 Bit serial I/F II	SDA: in SDO: out

Note 2: Interface mode select. IM1+IM2 are connected in parallel, IM0 is fixed to GND

TIMING CHARACTERISTICS (DETAILS REFER TO ST7789V)

Z80/8080 SERIES PARALLEL INTERFACE CHARACTERISTICS: 16/8-BIT BUS

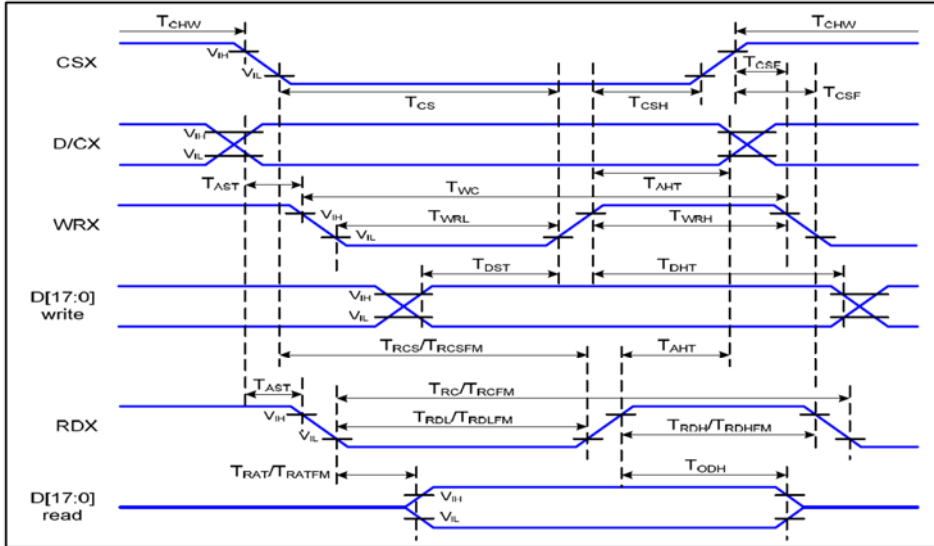

Figure 1 Parallel Interface Timing Characteristics (8080-Series MCU Interface)

VDDI=1.65 to 3.3V, VDD=2.4 to 3.3V, AGND=DGND=0V, Ta=25°C

Signal	Symbol	Parameter	Min	Max	Unit	Description
D/CX	T _{AST}	Address setup time	0		ns	-
	T _{AHT}	Address hold time (Write/Read)	10		ns	
CSX	T _{CHW}	Chip select "H" pulse width	0		ns	-
	T _{CS}	Chip select setup time (Write)	15		ns	
	T _{RCS}	Chip select setup time (Read ID)	45		ns	
	T _{RCSFM}	Chip select setup time (Read FM)	355		ns	
	T _{CSF}	Chip select wait time (Write/Read)	10		ns	
	T _{CSH}	Chip select hold time	10		ns	
WRX	T _{WC}	Write cycle	66		ns	
	T _{WRH}	Control pulse "H" duration	15		ns	
	T _{WRL}	Control pulse "L" duration	15		ns	
RDX (ID)	T _{RC}	Read cycle (ID)	160		ns	When read ID data
	T _{RDH}	Control pulse "H" duration (ID)	90		ns	
	T _{RDL}	Control pulse "L" duration (ID)	45		ns	
RDX (FM)	T _{RCFM}	Read cycle (FM)	450		ns	When read from frame memory
	T _{RDHFM}	Control pulse "H" duration (FM)	90		ns	
	T _{RDLFM}	Control pulse "L" duration (FM)	355		ns	
D[17:0]	T _{DST}	Data setup time	10		ns	For CL=30pF
	T _{DHT}	Data hold time	10		ns	
	T _{RAT}	Read access time (ID)		40	ns	
	T _{RATFM}	Read access time (FM)		340	ns	
	T _{ODH}	Output disable time	20	80	ns	

SERIAL INTERFACE CHARACTERISTICS (4-LINE SERIAL)

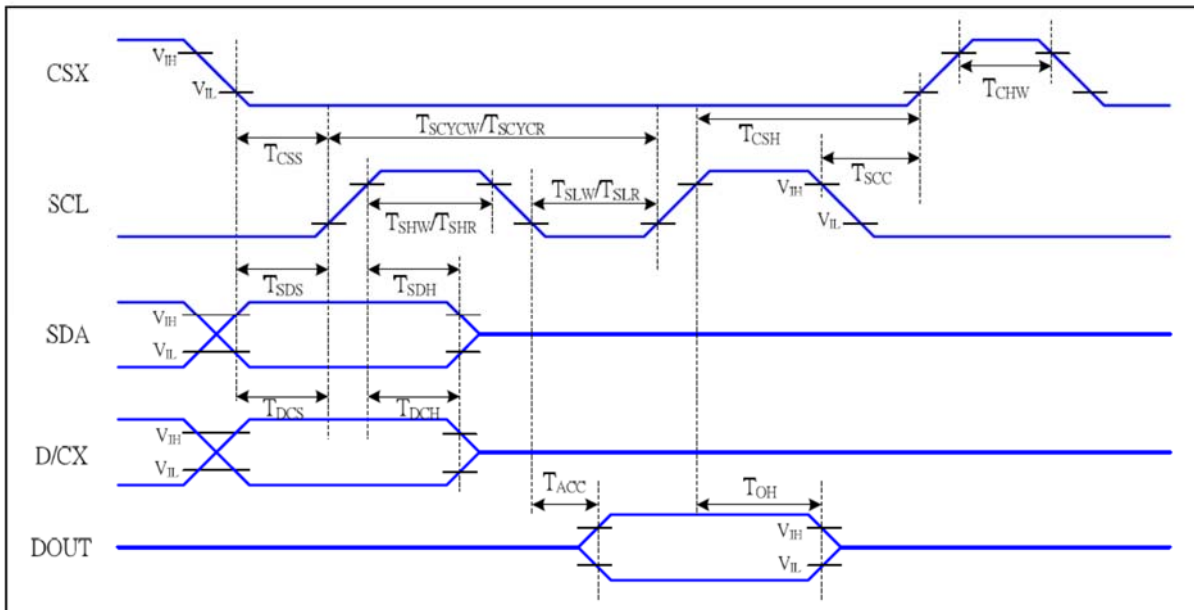

Figure 5 4-line serial Interface Timing Characteristics

VDDI=1.65 to 3.3V, VDD=2.4 to 3.3V, AGND=DGND=0V, Ta=25°C

Signal	Symbol	Parameter	MIN	MAX	Unit	Description
CSX	T _{CSS}	Chip select setup time (write)	15		ns	
	T _{CSH}	Chip select hold time (write)	15		ns	
	T _{CSS}	Chip select setup time (read)	60		ns	
	T _{SCC}	Chip select hold time (read)	65		ns	
	T _{CHW}	Chip select "H" pulse width	40		ns	
SCL	T _{SCYCW}	Serial clock cycle (Write)	66		ns	-write command & data ram
	T _{SHW}	SCL "H" pulse width (Write)	15		ns	
	T _{SLW}	SCL "L" pulse width (Write)	15		ns	
	T _{SCYCR}	Serial clock cycle (Read)	150		ns	-read command & data ram
	T _{SHR}	SCL "H" pulse width (Read)	60		ns	
	T _{SLR}	SCL "L" pulse width (Read)	60		ns	
D/CX	T _{DCS}	D/CX setup time	10		ns	
	T _{DCH}	D/CX hold time	10		ns	
SDA (DIN)	T _{SDS}	Data setup time	10		ns	
	T _{SDH}	Data hold time	10		ns	
DOUT	T _{ACC}	Access time	10	50	ns	For maximum CL=30pF
	T _{OH}	Output disable time	15	50	ns	For minimum CL=8pF

Table 6 4-line serial Interface Characteristics

RGB INTERFACE CHARACTERISTICS

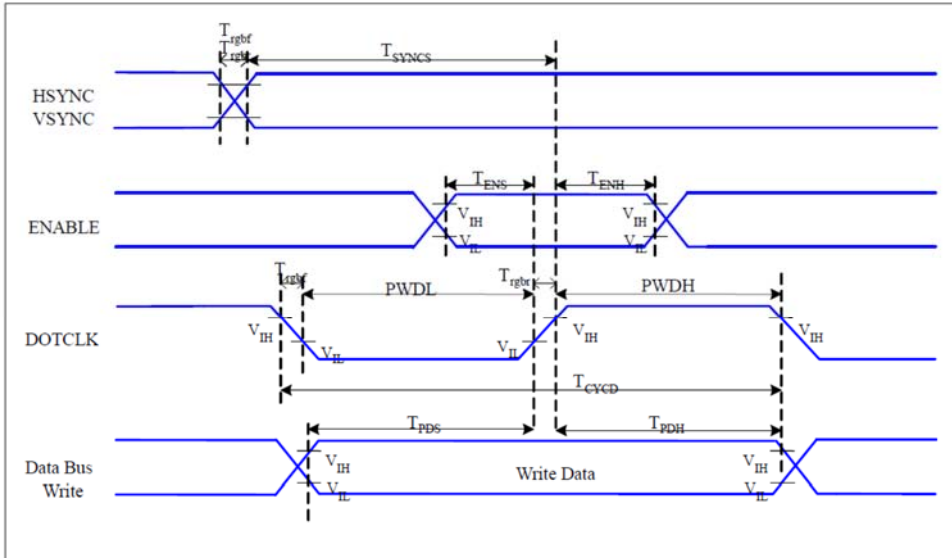

Figure 6 RGB Interface Timing Characteristics

VDDI=1.65 to 3.3V, VDD=2.4 to 3.3V, AGND=DGND=0V, Ta=25 °C

Signal	Symbol	Parameter	MIN	MAX	Unit	Description
HSYNC, VSYNC	T_{SYNCS}	VSYNC, HSYNC Setup Time	30	-	ns	
ENABLE	T_{ENS}	Enable Setup Time	25	-	ns	
	T_{ENH}	Enable Hold Time	25	-	ns	
DOTCLK	PWDH	DOTCLK High-level Pulse Width	60	-	ns	
	PWDL	DOTCLK Low-level Pulse Width	60	-	ns	
	T_{CYCD}	DOTCLK Cycle Time	120	-	ns	
	Trghr, Trghf	DOTCLK Rise/Fall time	-	20	ns	
DB	T_{PDS}	PD Data Setup Time	50	-	ns	
	T_{PDH}	PD Data Hold Time	50	-	ns	

Table 7 18/16 Bits RGB Interface Timing Characteristics

Signal	Symbol	Parameter	MIN	MAX	Unit	Description
HSYNC, VSYNC	T_{SYNCS}	VSYNC, HSYNC Setup Time	25	-	ns	
ENABLE	T_{ENS}	Enable Setup Time	25	-	ns	
	T_{ENH}	Enable Hold Time	25	-	ns	
DOTCLK	PWDH	DOTCLK High-level Pulse Width	25	-	ns	
	PWDL	DOTCLK Low-level Pulse Width	25	-	ns	
	T_{CYCD}	DOTCLK Cycle Time	55	-	ns	
	Trghr, Trghf	DOTCLK Rise/Fall time	-	10	ns	
DB	T_{PDS}	PD Data Setup Time	25	-	ns	
	T_{PDH}	PD Data Hold Time	25	-	ns	

Table 8 6 Bits RGB Interface Timing Characteristics

RESET TIMING

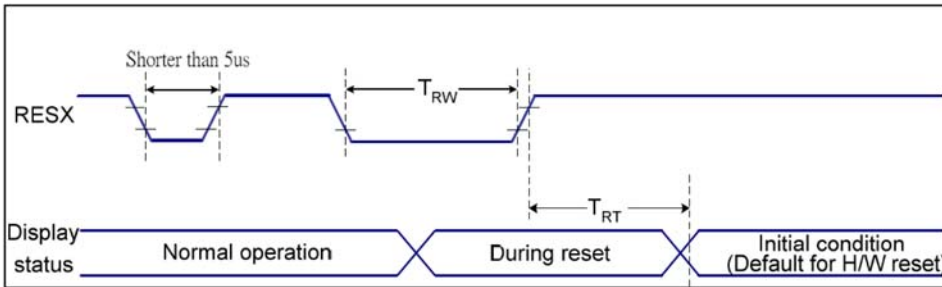

Figure 7 Reset Timing

VDDI=1.65 to 3.3V, VDD=2.4 to 3.3V, AGND=DGND=0V, Ta=25°C

Related Pins	Symbol	Parameter	MIN	MAX	Unit
RESX	TRW	Reset pulse duration	10	-	us
	TRT	Reset cancel	-	5 (Note 1, 5)	ms
			120 (Note 1, 6, 7)	ms	

Table 9 Reset Timing

Notes:

- The reset cancel includes also required time for loading ID bytes, VCOM setting and other settings from NVM (or similar device) to registers. This loading is done every time when there is HW reset cancel time (tRT) within 5 ms after a rising edge of RESX.
- Spike due to an electrostatic discharge on RESX line does not cause irregular system reset according to the table below:

RESX Pulse	Action
Shorter than 5us	Reset Rejected
Longer than 9us	Reset
Between 5us and 9us	Reset starts

- During the Resetting period, the display will be blanked (The display is entering blanking sequence, which maximum time is 120 ms, when Reset Starts in Sleep Out -mode. The display remains the blank state in Sleep In -mode.) and then return to Default condition for Hardware Reset.

- Spike Rejection also applies during a valid reset pulse as shown below:

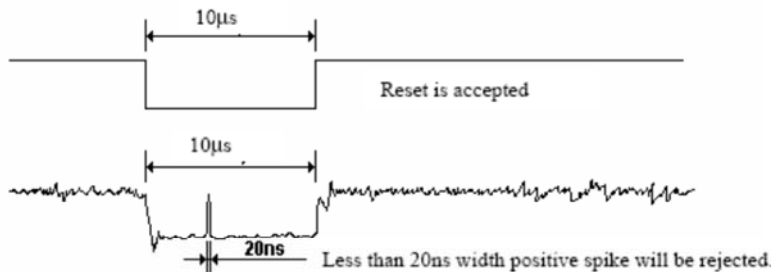

- When Reset applied during Sleep In Mode.
- When Reset applied during Sleep Out Mode.
- It is necessary to wait 5msec after releasing RESX before sending commands. Also Sleep Out command cannot be sent for 120msec.

RELIABILITY AND INSPECTION STANDARD

No.	Test Item		Test Conditions	Remark
1	High Temperature	Storage	70°C, 120Hr	Note
		Operation	60°C, 120Hr	Note
2	Low Temperature	Storage	-30°C, 120Hr	Note
		Operation	-20°C, 120Hr	
3	High Temperature and High Humidity		40°C, 90%RH, 120Hr	Note
4	Thermal Cycling Test(No operation)		-20C for 30min, 70c for 30 min. 100 cycles. Then test at room temperature after 1 hour	Note
5	Vibration Test(No operation)		Frequency :10~55 HZ; Stroke :1.5 mm;Sweep:10HZ~55HZ~10HZ; 2hours for each direction of X, Y, Z(6 hours for total)	
6	Package Drop Test		Height:60 cm,1 corner, 3 edges, 6 surfaces	
7	Electro Static Discharge		±2KV,Human Body Mode, 100pF/1500Ω	

Note:Sample quantity for each test item is 5~10pcs.

Note 4: Before cosmetic and function test, the product must have enough recovery time, at least 2 hours at room temperature.

INITIALIZATION EXAMPLE

```

WriteComm(0x01);
Delay(200);

//-----//
WriteComm(0x11);
Delay(120); //Delay 120ms

//-----display and color format setting-----//
WriteComm(0x36); WriteData(0x00);
WriteComm(0x3a); WriteData(0x05);
WriteComm(0x21);

//-----ST7789V Frame rate setting-----//
WriteComm(0xb2); WriteData(0x05); WriteData(0x05); WriteData(0x00); WriteData(0x33); WriteData(0x33);
WriteComm(0xb7); WriteData(0x35);

//-----ST7789V Power setting-----//
WriteComm(0xb8); WriteData(0x2f); WriteData(0x2b);WriteData(0x2f);
WriteComm(0xbb); WriteData(0x2B);
WriteComm(0xc0); WriteData(0x2c);
WriteComm(0xc2); WriteData(0x01);
WriteComm(0xc3); WriteData(0x0b);
WriteComm(0xc4); WriteData(0x20);
WriteComm(0xc6); WriteData(0x11);
WriteComm(0xd0); WriteData(0xa4); WriteData(0xa1);
WriteComm(0xe8); WriteData(0x03);
WriteComm(0xe9); WriteData(0x0d); WriteData(0x12); WriteData(0x00);

//-----ST7789V gamma setting-----//
WriteComm(0xe0); WriteData(0xd0); WriteData(0x06); WriteData(0x0b); WriteData(0x0a); WriteData(0x09);
WriteData(0x05); WriteData(0x2e); WriteData(0x43); WriteData(0x44); WriteData(0x09); WriteData(0x16);
WriteData(0x15); WriteData(0x23); WriteData(0x27);

WriteComm(0xe1); WriteData(0xd0); WriteData(0x06); WriteData(0x0b); WriteData(0x09); WriteData(0x08);
WriteData(0x06); WriteData(0x2e); WriteData(0x44); WriteData(0x44); WriteData(0x3a); WriteData(0x15);
WriteData(0x15); WriteData(0x23); WriteData(0x26);

//-----Init RGB-Mode-----
WriteComm(0x3A); //Interface Pixel Format
WriteData(0x55); //RGB 65K Colors, Control interface 16bit/pixel

WriteComm(0xB0); //RAM access control
WriteData(0x11); //RGB interface access RAM, Display operation RGB interface
WriteData(0xE0); //16 Bit color format R7 -> R0, MSB first, 18 bit bus width,

WriteComm(0xB1); //RGB interfacecontrol
WriteData(0xEF); //Direct RGB mode, RGB DE Mode, Control pins high active
WriteData(0x08); //VSYNC Back porch setting
WriteData(0x14); //HSYNC Back porch setting

//-----Display on-----
WriteComm(0x11);
Delay(120); //Delay 120ms

WriteComm(0x29);
Delay(100);

```

PCAP CONTROLLER GT911

preliminary

PRECAUTIONS FOR USING LCD MODULES

HANDING PRECAUTIONS

- (1) The display panel is made of glass and polarizer. As glass is fragile, it tends to become or chipped during handling especially on the edges. Please avoid dropping or jarring. Do not subject it to a mechanical shock by dropping it or impact.
- (2) If the display panel is damaged and the liquid crystal substance leaks out, be sure not to get any in your mouth. If the substance contacts your skin or clothes, wash it off using soap and water.
- (3) Do not apply excessive force to the display surface or the adjoining areas since this may cause the color tone to vary. Do not touch the display with bare hands. This will stain the display area and degraded insulation between terminals (some cosmetics are determined to the polarizer).
- (4) The polarizer covering the display surface of the LCD module is soft and easily scratched. Handle this polarizer carefully. Do not touch, push or rub the exposed polarizers with anything harder than an HB pencil lead (glass, tweezers, etc.). Do not put or attach anything on the display area to avoid leaving marks on. Condensation on the surface and contact with terminals due to cold will damage, stain or dirty the polarizer. After products are tested at low temperature they must be warmed up in a container before coming is contacting with room temperature air.
- (5) If the display surface becomes contaminated, breathe on the surface and gently wipe it with a soft dry cloth. If it is heavily contaminated, moisten cloth with one of the following solvents
 - Isopropyl alcohol
 - Ethyl alcoholDo not scrub hard to avoid damaging the display surface.
- (6) Solvents other than those above-mentioned may damage the polarizer. Especially, do not use the following:
 - Water
 - Ketone
 - Aromatic solventsWipe off saliva or water drops immediately, contact with water over a long period of time may cause deformation or color fading. Avoid contacting oil and fats.
- (7) Exercise care to minimize corrosion of the electrode. Corrosion of the electrodes is accelerated by water droplets, moisture condensation or a current flow in a high-humidity environment.
- (8) Install the LCD Module by using the mounting holes. When mounting the LCD module make sure it is free of twisting, warping and distortion. In particular, do not forcibly pull or bend the I/O cable or the backlight cable.
- (9) Do not attempt to disassemble or process the LCD module.
- (10) NC terminal should be open. Do not connect anything.
- (11) If the logic circuit power is off, do not apply the input signals.
- (12) Since LCM has been assembled and adjusted with a high degree of precision, avoid applying excessive shocks to the module or making any alterations or modifications to it.
 - Do not alter, modify or change the shape of the tab on the metal frame.
 - Do not make extra holes on the printed circuit board, modify its shape or change the positions of components to be attached.
 - Do not damage or modify the pattern writing on the printed circuit board.
 - Absolutely do not modify the zebra rubber strip (conductive rubber) or heat seal connector.
 - Except for soldering the interface, do not make any alterations or modifications with a soldering iron.
 - Do not drop, bend or twist LCM.

STORAGE PRECAUTIONS

When storing the LCD modules, the following precaution is necessary.

- (1) Store them in a sealed polyethylene bag. If properly sealed, there is no need for the dessicant.
- (2) Store them in a dark place. Do not expose to sunlight or fluorescent light, keep the temperature between 0°C and 35°C.
- (3) The polarizer surface should not come in contact with any other objects. (We advise you to store them in the container in which they were shipped).

OTHERS

Liquid crystals solidify under low temperature (below the storage temperature range) leading to defective orientation or the generation of air bubbles (black or white). Air bubbles may also be generated if the module is subject to a low temperature.

If the LCD modules have been operating for a long time showing the same display patterns, the display patterns may remain on the screen as ghost images and a slight contrast irregularity may also appear. A normal operating status can be regained by suspending use for some time. It should be noted that this phenomenon does not adversely affect performance reliability.

To minimize the performance degradation of the LCD modules resulting from destruction caused by static electricity etc., exercise care to avoid holding the following sections when handling the modules.

- Exposed area of the printed circuit board.
- Terminal electrode sections.

OUTLINE DIMENSION

- Preliminary-

