

**DISPLAY Elektronik GmbH**

# DATA SHEET

*TFT MODULE*

**DEM 80048001 VMH-PW-N  
(A-TOUCH)**

**7,0" TFT**

Product Specification

Ver.: 0

25.05.2020

**Revision History**

<b>Revision</b>	<b>Date</b>	<b>Originator</b>	<b>Detail</b>	<b>Remarks</b>
0	25.05.2020	MHI	Initial Release	

**Table of Contents**

No.	Item	Page
1.	General Description .....	4
2.	Module Parameter .....	4
3.	Absolute Maximum Ratings .....	4
4.	DC Characteristics .....	5
5.	Backlight Characteristic .....	5
5.1.	Backlight Characteristic .....	5
5.2.	Backlighting circuit .....	5
6.	Touch Screen Panel Specifications.....	6
7.	Optical Characteristics .....	7
7.1.	Optical Characteristics .....	7
7.2.	Definition of Response Time .....	7
7.3.	Definition of Contrast Ratio .....	8
7.4.	Definition of Viewing Angles.....	8
7.5.	Definition of Color Appearance .....	9
7.6.	Definition of Surface Luminance, Uniformity and Transmittance.....	9
8.	Block Diagram and Power Supply .....	10
9.	Interface Pins Definition .....	11
10.	AC Characteristics .....	13
10.1.	Timing Characteristics of input signals .....	13
10.2.	Data Input format .....	13
10.3.	Timing.....	14
10.	Quality Assurance .....	15
10.1.	Purpose .....	15
10.2.	Standard for Quality Test.....	15
10.3.	Nonconforming Analysis & Disposition .....	15
10.4.	Agreement Items.....	15
10.5.	Standard of the Product Visual Inspection .....	15
10.6.	Inspection Specification .....	16
10.7.	Classification of Defects.....	21
10.8.	Identification/marketing criteria .....	21
10.9.	Packing .....	21
11.	Reliability Specification .....	22
12.	Precautions and Warranty .....	23
12.1.	Safety .....	23
12.2.	Handling .....	23
12.3.	Storage.....	23
12.4.	Metal Pin (Apply to Products with Metal Pins) .....	23
12.5.	Operation .....	24
12.6.	Static Electricity .....	24
12.7.	Limited Warranty .....	24
13.	Outline Drawing .....	25

**1. General Description**

The specification is a transmissive type color active matrix liquid crystal display (LCD) which uses amorphous thin film transistor (TFT) as switching devices. This product is composed of a TFT-LCD panel, driver ICs, a touch panel and a backlight unit.

**2. Module Parameter**

Features	Details	Unit
Display Size(Diagonal)	7.0"	
LCD Type	MVA TFT	
Display Mode	Transmissive / Normally White	
Resolution	800 RGB x 480	Pixels
View Direction	Full viewing	Best Image
Module Outline	165.00 x 104.00 x 4.70	mm
Active Area	154.08 x 85.92	mm
Pixel Size	0.1926 x 0.1790	mm
Pixel Arrangement	RGB- Island	
Polarizer Surface Treatment	Anti-Glare	
Driver IC	EK9713& EK73002	
Display Colors	16.7 Million	
Interface	24bits-RGB Interface	
With or Without Touch Panel	With	-
Operating Temperature	-20~70	°C
Storage Temperature	-30~80	°C
Weight	TBD	g

Note 1: Exclusive hooks, post, FFC/FPC tail etc.

**3. Absolute Maximum Ratings**

$V_{SS}=0V, T_a=25^{\circ}C$

Item	Symbol	Min.	Max.	Unit
Power Supply Voltage	VDD	-0.3	5.0	V
Storage Temperature	$T_{STG}$	-30	+80	°C
Operating Temperature	$T_{OP}$	-20	+70	°C

**Note 1:** If  $T_a$  below  $50^{\circ}C$ , the maximal humidity is 90%RH, if  $T_a$  over  $50^{\circ}C$ , absolute humidity should be less than 60%RH.

**Note 2:** The response time will be extremely slow when the operating temperature is around  $-10^{\circ}C$ , and the back ground will become darker at high temperature operating.

4. DC Characteristics

Item	Symbol	Min.	Typ.	Max.	Unit	
Supply Voltage	VDD	3.0	3.3	3.6	V	
Logic Low Input Voltage	V <sub>IL</sub>	GND	-	0.3*VDD	V	
Logic High Input Voltage	V <sub>IH</sub>	0.7*VDD	-	VDD	V	
Current Consumption All Black	Logic	I <sub>CC+ I<sub>IN</sub></sub>	-	TBD	-	mA
	Analog					

5. Backlight Characteristic

5.1. Backlight Characteristic

Item	Symbol	Condition	Min.	Typ.	Max.	Unit
Backlight Voltage	V <sub>LED</sub>	Ta=25 °C, I <sub>F</sub> =20mA/LED	8.7	9.6	9.9	V
Backlight Current	I <sub>LED</sub>	Ta=25 °C, V <sub>F</sub> =3.2V/LED	-	180	-	mA
Power Dissipation	P <sub>D</sub>	-	-	1728	-	mW
Uniformity	Avg	-	70	75	-	%
LED Lifetime (25°C)	-	-	20000	30,000	-	Hrs
Drive Method	Constant Current					
LED Configuration	27 White LEDs ( 3 LEDs in one string and 9 groups in parallel)					

Note1: LED life time defined as follows: The final brightness is at 50% of original brightness.  
 The environmental conducted under ambient air flow, at Ta=25± 2 °C,60%RH± 5%,  
 I<sub>F</sub>=20mA/LED.

5.2. Backlighting circuit

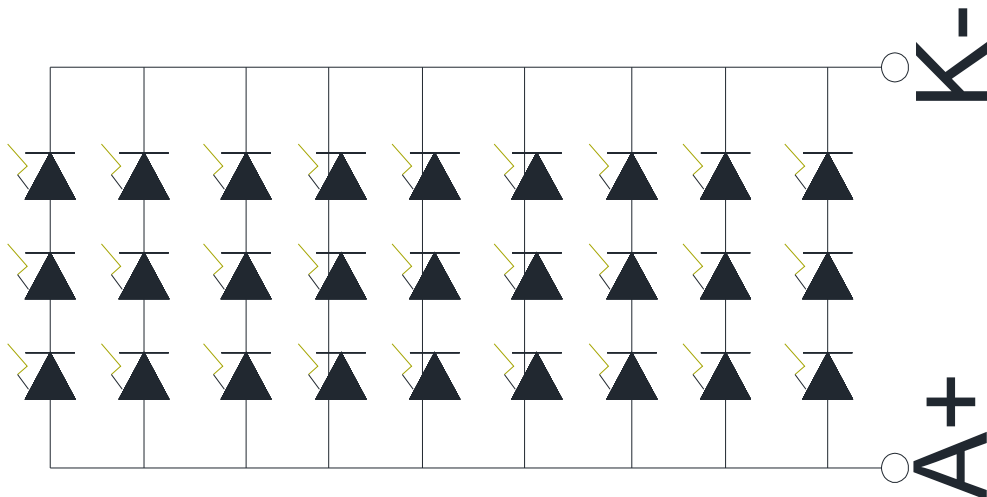

**6. Touch Screen Panel Specifications**

6.1 Electrical Characteristics

Item	Min.	Typ.	Max.	Unit	Note
Linearity	-3	-	3	%	Analog X and Y directions
Terminal Resistance	50	-	400	$\Omega$	X (Film side)
	350	-	1100	$\Omega$	Y (Glass side)
Insulation Resistance	20	-	-	M $\Omega$	DC $\leq$ 10V
Voltage	-	-	10	V	DC
Chattering	-	-	10	ms	

Caution (1) : Do not operate it with a thing except a polyacetal pen (tip R0.8mm or less) or a finger, especially those with hard or sharp tips such as a ball point pen or a mechanical pencil.

6.2 Mechanical & Reliability Characteristics

Item	Min.	Typ.	Max.	Unit	Note
Activation Force	10	-	100	g	(1)
Durability-Surface Scratching	Write 20,000	-	-	characters	(2)
Durability-Surface Pitting	1,000,000	-	-	touches	(3)
Surface Hardness	3	-	-	H	

Note (1) Stylus pen Input: R0.8mm polyacetal pen or Finger

Note (2) Measurement for Surface area.

- Force: 150-250gf
- Speed: 60mm/sec
- Stylus: R0.8 polyacetal pen or Finger

Note (3) Pit 1,000,000 times on the Film with a R3.75 silicon rubber.

- Force: Force: 2.45N
- Speed: 3times/sec

7. Optical Characteristics

7.1. Optical Characteristics

Ta=25°C, DVDD=3.3V

	Item	Symbol	Condition	Specification			Unit	
				Min.	Typ.	Max.		
Backlight On (Transmissive Mode)	Luminance On TFT( $I_f=20\text{mA/LED}$ )	Lv	Normally viewing angle $\theta_x = \phi_y = 0^\circ$	260	330	-	cd/m <sup>2</sup>	
	Contrast Ratio(See 7.3)	CR		500	800	-		
	Response Time (See 7.2)	TR+TF		-	25	50	ms	
	Chromaticity Transmissive (See 7.5)	Red	X <sub>R</sub>	Center CR≥10	-	TBD	-	
			Y <sub>R</sub>		-	TBD	-	
		Green	X <sub>G</sub>		-	TBD	-	
			Y <sub>G</sub>		-	TBD	-	
		Blue	X <sub>B</sub>		-	TBD	-	
			Y <sub>B</sub>		-	TBD	-	
	White	X <sub>W</sub>	-	TBD	-			
Y <sub>W</sub>		-	TBD	-				
Viewing Angle (See 7.4)	Horizontal	$\theta_{x+}$	Center CR≥10	60	75	-	Deg.	
		$\theta_{x-}$		60	75	-		
	Vertical	$\phi_{y+}$		60	75	-		
		$\phi_{y-}$		60	75	-		
NTSC Ratio(Gamut)				41	51	-	%	

7.2. Definition of Response Time

7.2.1. Normally Black Type (Negative)

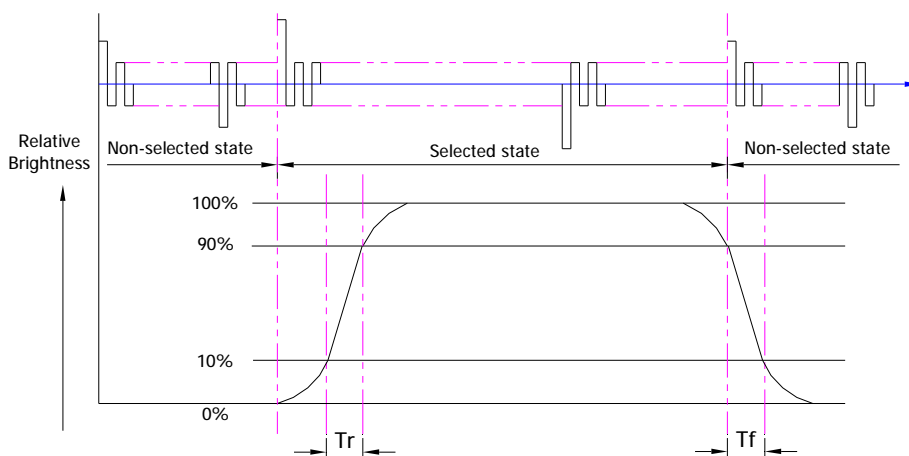

Tr is the time it takes to change from non-selected stage with relative luminance 10% to selected state with relative luminance 90%;

Tf is the time it takes to change from selected state with relative luminance 90% to non-selected state with relative luminance 10%.

Note: Measuring machine: LCD-5100

7.2.2. Normally White Type (Positive)

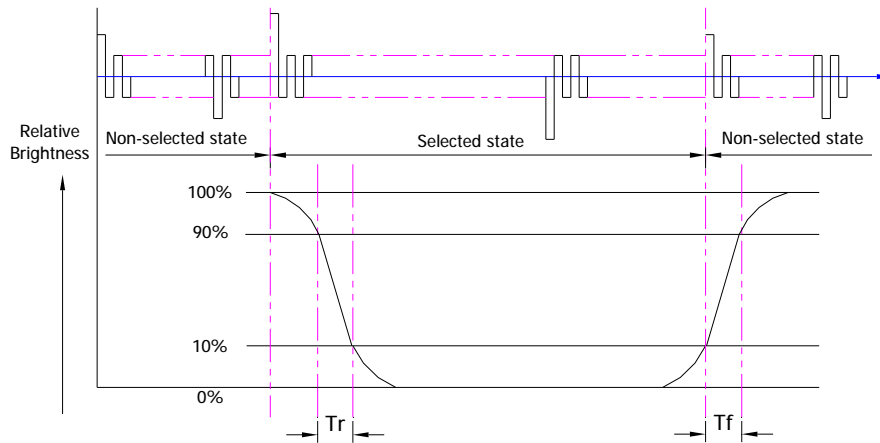

Tr is the time it takes to change from non-selected stage with relative luminance 90% to selected state with relative luminance 10%;

Tf is the time it takes to change from selected state with relative luminance 10% to non-selected state with relative luminance 90%;

Note: Measuring machine: LCD-5100 or EQUI

7.3. Definition of Contrast Ratio

Contrast is measured perpendicular to display surface in reflective and transmissive mode.

The measurement condition is:

Measuring Equipment	Eldim or Equivalent
Measuring Point Diameter	3mm//1mm
Measuring Point Location	Active Area centre point
Test Pattern	A: All Pixels white
	B: All Pixel black
Contrast Setting	Maximum

Definitions: CR (Contrast) = Luminance of White Pixel / Luminance of Black Pixel

7.4. Definition of Viewing Angles

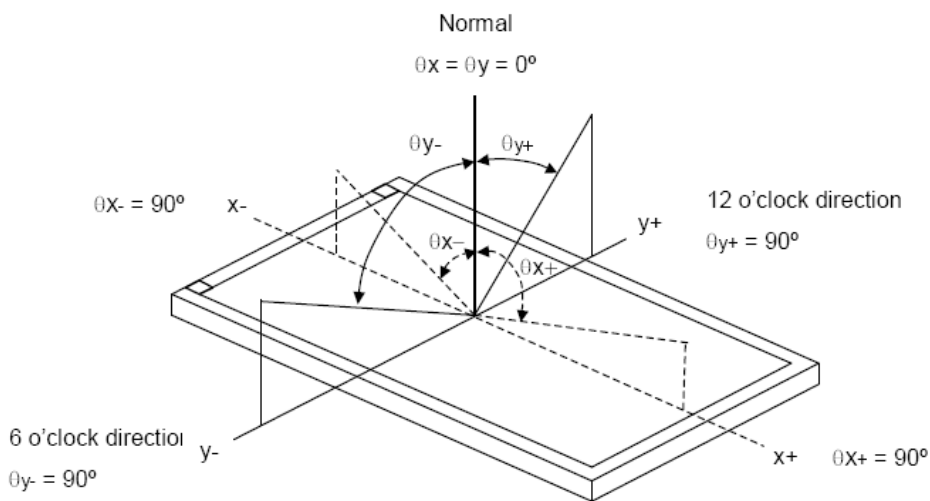

Measuring machine: LCD-5100 or EQUI



**7.5. Definition of Color Appearance**

R, G, B and W are defined by (x, y) on the IE chromaticity diagram

NTSC=area of RGB triangle/area of NTSC triangleX100%

Measuring picture: Red, Green, Blue and White (Measuring machine: BM-7)

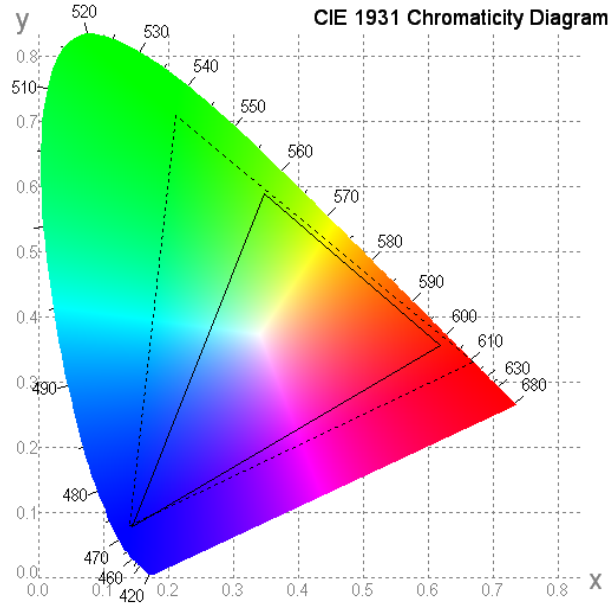

**7.6. Definition of Surface Luminance, Uniformity and Transmittance**

Using the transmissive mode measurement approach, measure the white screen luminance of the display panel and backlight.

- 7.6.1. Surface Luminance:  $L_v = \text{average} (L_{P1}:L_{P9})$
- 7.6.2. Uniformity =  $\text{Minimal} (L_{P1}:L_{P9}) / \text{Maximal} (L_{P1}:L_{P9}) * 100\%$
- 7.6.3. Transmittance =  $L_v \text{ on LCD} / L_v \text{ on Backlight} * 100\%$

Note: Measuring machine: BM-7

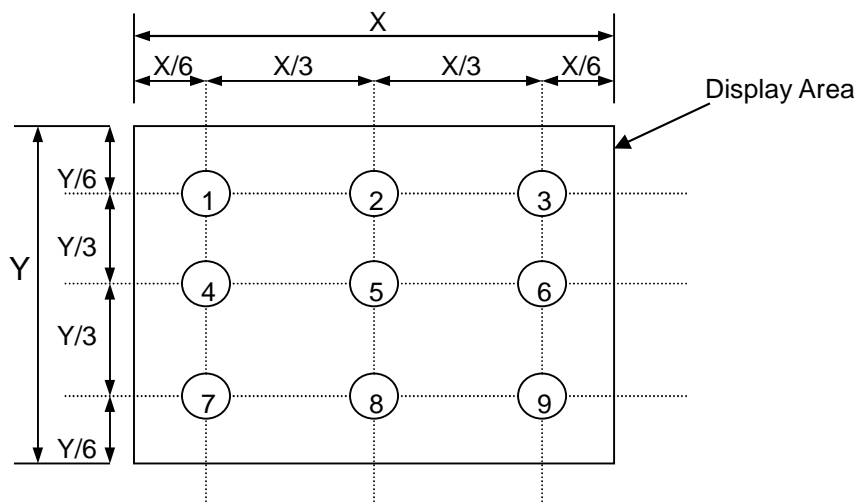

8. Block Diagram and Power Supply

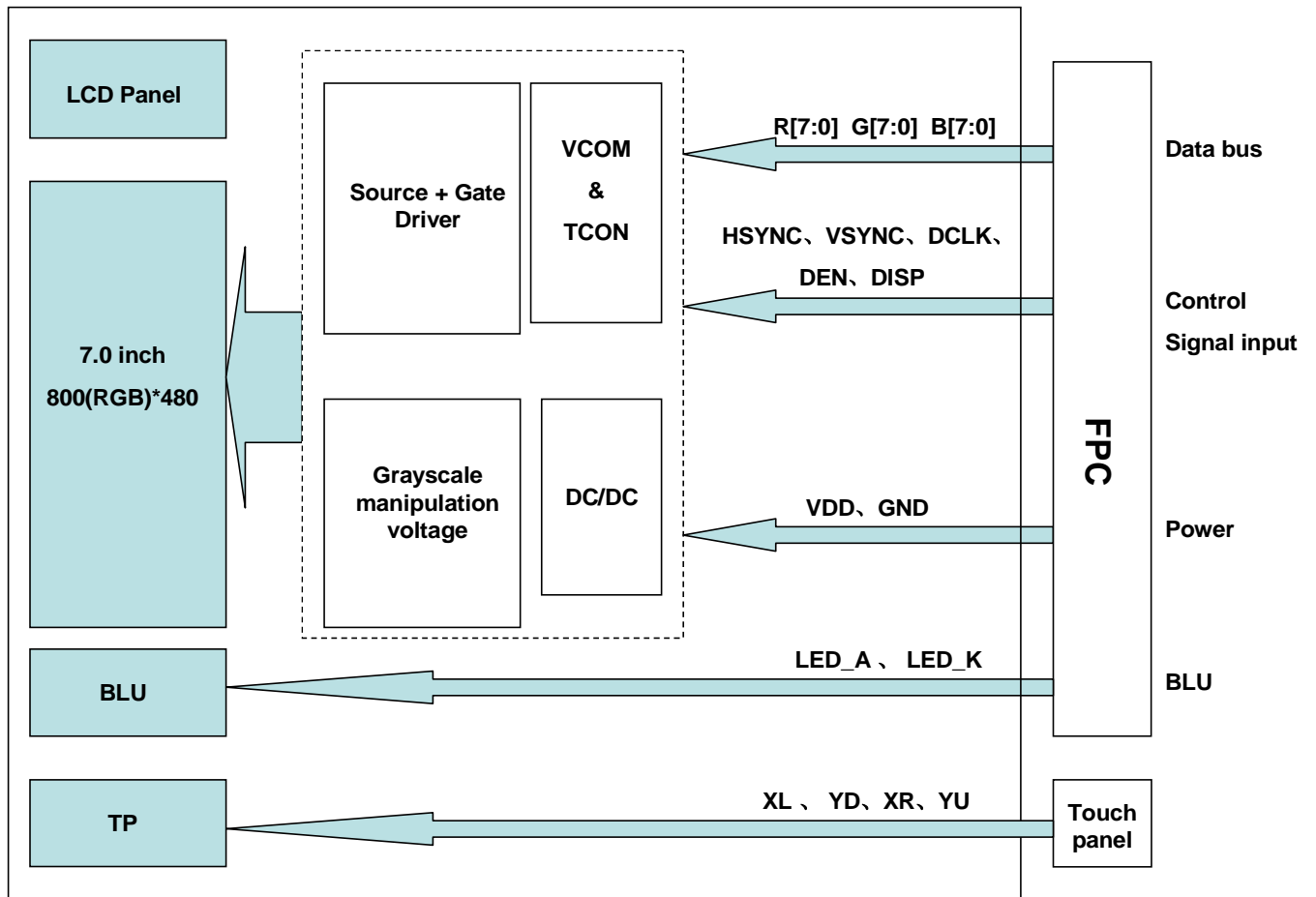

**9. Interface Pins Definition**

No.	Symbol	Function
1	LED_K	LED backlight(Cathode)
2	LED_A	LED backlight(Anode)
3	GND	Ground
4	VDD	Power supply
5	R0	Red Data
6	R1	Red Data
7	R2	Red Data
8	R3	Red Data
9	R4	Red Data
10	R5	Red Data
11	R6	Red Data
12	R7	Red Data
13	G0	Green Data
14	G1	Green Data
15	G2	Green Data
16	G3	Green Data
17	G4	Green Data
18	G5	Green Data
19	G6	Green Data
20	G7	Green Data
21	B0	Blue Data
22	B1	Blue Data
23	B2	Blue Data
24	B3	Blue Data
25	B4	Blue Data
26	B5	Blue Data
27	B6	Blue Data
28	B7	Blue Data
29	GND	Ground
30	DCLK	Dot data clock
31	DISP	Display on/off. DISP=1:Display on.
32	HSYNC	Horizontal sync input in RGB mode(short to GND if not used)
33	VSYNC	Vertical sync input in RGB mode(short to GND if not used)
34	DEN	Data Enable. Active high to enable the data input bus.
35	NC	No connection
36	GND	Ground
37	NC(XR)	No connection
38	NC(YD)	No connection
39	NC(XL)	No connection
40	NC(YU)	No connection

**PIN Assignment**

<b>No.</b>	<b>Symbol</b>	<b>Function</b>
1	XL	Touch panel terminal
2	YD	Touch panel terminal
3	XR	Touch panel terminal
4	YU	Touch panel terminal

10. AC Characteristics

10.1. Timing Characteristics of input signals

Parameter	Symbol	Spec.			Unit
		Min.	typ.	Max.	
HS setup time	$T_{hst}$	8	-	-	ns
HS hold time	$T_{hhd}$	8	-	-	ns
VS setup time	$T_{vst}$	8	-	-	ns
VS hold time	$T_{vhd}$	8	-	-	ns
Data setup time	$T_{dsu}$	8	-	-	ns
Data hold time	$T_{dhd}$	8	-	-	ns
DE setup time	$T_{esu}$	8	-	-	ns
DE hold time	$T_{ehd}$	8	-	-	ns
VDD Power On Slew rate	$T_{POR}$	-	-	20	ms
RSTB pulse width	$T_{Rst}$	10	-	-	us
CLKIN cycle time	$T_{cph}$	20	-	-	ns
CLKIN pulse duty	$T_{cwh}$	40	50	60	%
Output stable time	$T_{sst}$	-	-	6	us

10.2. Data Input format



Horizontal input timing diagram

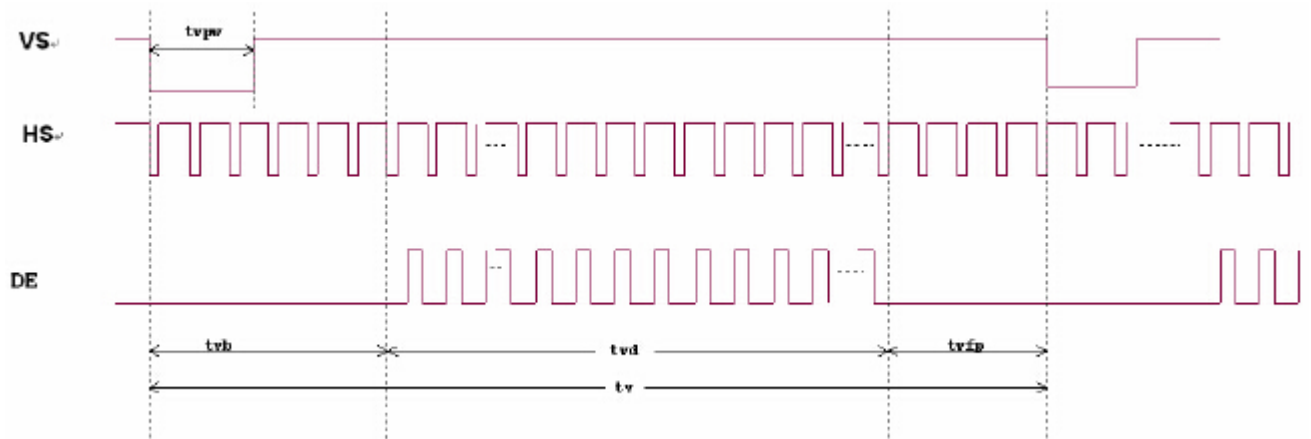

Vertical input timing diagram

10.3. Timing

Item	Symbol	Values			Unit	Remark
		Min.	Typ.	Max.		
Horizontal Display Area	thd	--	800	--	DCLK	
DCLK Frequency	fclk	26.4	33.3	46.8	MHz	
One Horizontal Line	th	862	1056	1200	DCLK	
HS Pulse Width	thpw	1	--	40	DCLK	
HS Blanking	thb	46	46	46	DCLK	
HS Front Porch	thfp	16	210	354	DCLK	

Item	Symbol	Values			Unit	Remark
		Min.	Typ.	Max.		
Vertical Display Area	tvd	--	480	--	TH	
VS Period Time	tv	510	525	650	TH	
VS Pulse Width	tvpw	1	--	20	TH	
VS Blanking	tvb	23	23	23	TH	
VS Front Porch	tvfp	7	22	147	TH	

## **10. Quality Assurance**

### **10.1.Purpose**

This standard for Quality Assurance assures the quality of LCD module products supplied to customer.

### **10.2.Standard for Quality Test**

#### 10.2.1. Sampling Plan:

GB2828.1-2012

Single sampling, general inspection level II

#### 10.2.2. Sampling Criteria:

Visual inspection: AQL 1.5

Electrical functional: AQL 0.65.

#### 10.2.3. Reliability Test:

Detailed requirement refer to Reliability Test Specification.

### **10.3.Nonconforming Analysis & Disposition**

#### 10.3.1. Nonconforming analysis:

10.3.1.1. Customer should provide overall information of non-conforming sample for their complaints.

10.3.1.2. After receipt of detailed information from customer, the analysis of nonconforming parts usually should be finished in one week.

10.3.1.3. If cannot finish the analysis on time, customer will be notified with the progress status.

#### 10.3.2. Disposition of nonconforming:

10.3.2.1. Non-conforming product over PPM level will be replaced.

10.3.2.2. The cause of non-conformance will be analyzed. Corrective action will be discussed and implemented.

### **10.4.Agreement Items**

Shall negotiate with customer if the following situation occurs:

10.4.1. There is any discrepancy in standard of quality assurance.

10.4.2. Additional requirement to be added in product specification.

10.4.3. Any other special problem.

### **10.5.Standard of the Product Visual Inspection**

#### 10.5.1. Appearance inspection:

10.5.1.1. The inspection must be under illumination about 1000 – 1500 lx, and the distance of view must be at 30cm ± 2cm.

10.5.1.2. The viewing angle should be 45° from the vertical line without reflection light or follows customer's viewing angle specifications.

10.5.1.3. Definition of area: A Zone: Active Area, B Zone: Viewing Area,

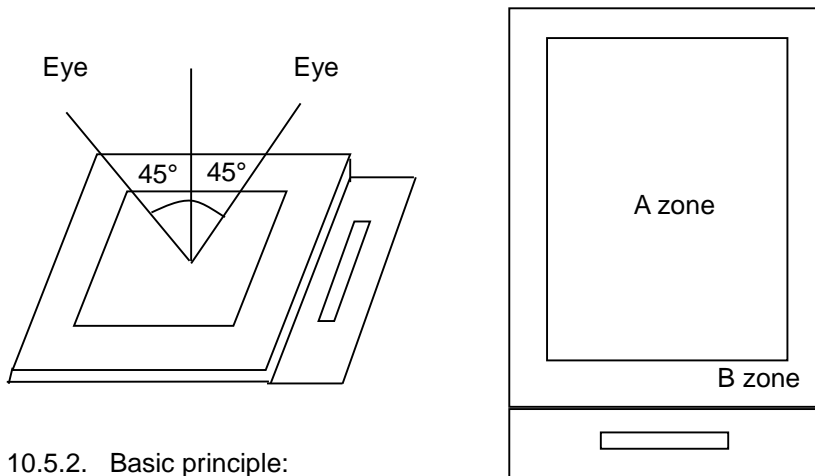

10.5.2. Basic principle:

10.5.2.1. A set of sample to indicate the limit of acceptable quality level must be discussed by both us and customer when there is any dispute happened.

10.5.2.2. New item must be added on time when it is necessary.

**10.6. Inspection Specification**

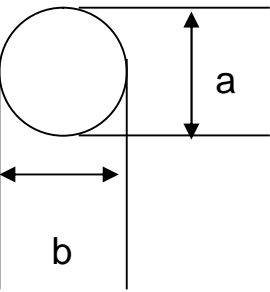
No.	Item	Criteria (Unit: mm)																		
01	Black / White Spot Foreign Material (Round Type) Pinholes Stain Particles Inside cell. (Minor Defect)	 <table border="1" data-bbox="909 929 1412 1153"> <thead> <tr> <th>Size</th> <th>Area</th> <th>Acc. Qty</th> </tr> </thead> <tbody> <tr> <td><math>\phi \leq 0.20</math></td> <td></td> <td>Ignore</td> </tr> <tr> <td><math>0.20 &lt; \phi \leq 0.50</math></td> <td></td> <td><math>N \leq 3</math></td> </tr> <tr> <td><math>0.50 &lt; \phi</math></td> <td></td> <td>0</td> </tr> </tbody> </table> <p><math>\phi = (a + b) / 2</math> Distance between 2 defects should more than 5mm apart.</p>	Size	Area	Acc. Qty	$\phi \leq 0.20$		Ignore	$0.20 < \phi \leq 0.50$		$N \leq 3$	$0.50 < \phi$		0						
Size	Area	Acc. Qty																		
$\phi \leq 0.20$		Ignore																		
$0.20 < \phi \leq 0.50$		$N \leq 3$																		
$0.50 < \phi$		0																		
02	Electrical Defect (Minor Defect)	<table border="1" data-bbox="550 1366 1412 1590"> <thead> <tr> <th>Bright dot</th> <th>Display Area</th> <th>Total</th> <th rowspan="3">Note1</th> </tr> </thead> <tbody> <tr> <td></td> <td><math>N \leq 2</math></td> <td><math>N \leq 2</math></td> </tr> <tr> <td>Dark dot</td> <td><math>N \leq 4</math></td> <td><math>N \leq 4</math></td> </tr> <tr> <td>Total dot</td> <td><math>N \leq 4</math></td> <td><math>N \leq 4</math></td> <td></td> </tr> <tr> <td>Mura</td> <td colspan="2">Not visible through 5% ND filters.</td> <td>Note 2</td> </tr> </tbody> </table> <p>Remark: 1. Bright dot caused by scratch and foreign object accords to item 1.</p>	Bright dot	Display Area	Total	Note1		$N \leq 2$	$N \leq 2$	Dark dot	$N \leq 4$	$N \leq 4$	Total dot	$N \leq 4$	$N \leq 4$		Mura	Not visible through 5% ND filters.		Note 2
Bright dot	Display Area	Total	Note1																	
	$N \leq 2$	$N \leq 2$																		
Dark dot	$N \leq 4$	$N \leq 4$																		
Total dot	$N \leq 4$	$N \leq 4$																		
Mura	Not visible through 5% ND filters.		Note 2																	

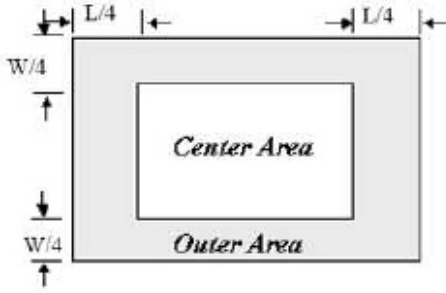
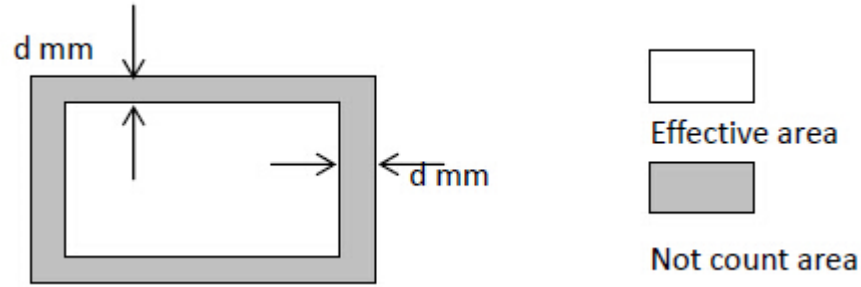

03	Inactive Area (Minor Defect)	<p>Line Criteria: <math>L \leq 1\text{mm}</math>, <math>W \leq 0.1\text{mm}</math>,                      Dot Criteria: Please refer to Note 1,2&amp;3                      Note1: Definition of Area</p>  <p>Note2:</p> <table border="1" data-bbox="531 701 1457 1077"> <thead> <tr> <th>尺寸</th> <th>缺圖</th> <th>中心 Center</th> <th>外圍 Outer</th> <th>總數 Total</th> <th>備註</th> </tr> </thead> <tbody> <tr> <td>All</td> <td><math>\varnothing &lt; 0.2\text{mm}</math>;</td> <td colspan="4">不計數</td> </tr> <tr> <td>&lt;6°</td> <td><math>0.2 \leq \varnothing \leq 0.3\text{mm}</math>; <math>L \leq 1\text{mm}, W \leq 0.1\text{mm}</math></td> <td><math>N \leq 1</math></td> <td><math>N \leq 2</math></td> <td><math>N \leq 3</math></td> <td></td> </tr> <tr> <td>6~8°</td> <td><math>0.2 \leq \varnothing \leq 0.5\text{mm}</math>; <math>L \leq 1\text{mm}, W \leq 0.1\text{mm}</math></td> <td><math>N \leq 2</math></td> <td><math>N \leq 3</math></td> <td><math>N \leq 5</math></td> <td>0.4 <math>\leq \varnothing \leq 0.5\text{mm}</math>, <math>N \leq 1</math> is allowed at outer.)</td> </tr> <tr> <td>8.1°~10.1°</td> <td><math>0.2 \leq \varnothing \leq 0.5\text{mm}</math>; <math>L \leq 1\text{mm}, W \leq 0.1\text{mm}</math></td> <td><math>N \leq 2</math></td> <td><math>N \leq 5</math></td> <td><math>N \leq 7</math></td> <td>0.4 <math>\leq \varnothing \leq 0.5\text{mm}</math>, <math>N \leq 2</math> is allowed at outer.)</td> </tr> <tr> <td>10.2°~15°</td> <td><math>0.2 \leq \varnothing \leq 0.5\text{mm}</math>; <math>L \leq 1\text{mm}, W \leq 0.1\text{mm}</math></td> <td><math>N \leq 5</math></td> <td><math>N \leq 10</math></td> <td><math>N \leq 15</math></td> <td>(0.4 <math>\leq \varnothing \leq 0.5\text{mm}</math>, <math>N \leq 5</math> is allowed at outer.)</td> </tr> </tbody> </table> <p>Note3: Inactive area <math>D &lt; 0.2\text{mm}</math> is not counted without appearance observation.                      Remark:                      Effective area is from the POL cutting side to 0.5mm of inside. This is no count area. Other part is effective area. In no count area, any defect can ignore. In effective area, have to judge from above-mentioned specification.</p> 	尺寸	缺圖	中心 Center	外圍 Outer	總數 Total	備註	All	$\varnothing < 0.2\text{mm}$ ;	不計數				<6°	$0.2 \leq \varnothing \leq 0.3\text{mm}$ ; $L \leq 1\text{mm}, W \leq 0.1\text{mm}$	$N \leq 1$	$N \leq 2$	$N \leq 3$		6~8°	$0.2 \leq \varnothing \leq 0.5\text{mm}$ ; $L \leq 1\text{mm}, W \leq 0.1\text{mm}$	$N \leq 2$	$N \leq 3$	$N \leq 5$	0.4 $\leq \varnothing \leq 0.5\text{mm}$ , $N \leq 1$ is allowed at outer.)	8.1°~10.1°	$0.2 \leq \varnothing \leq 0.5\text{mm}$ ; $L \leq 1\text{mm}, W \leq 0.1\text{mm}$	$N \leq 2$	$N \leq 5$	$N \leq 7$	0.4 $\leq \varnothing \leq 0.5\text{mm}$ , $N \leq 2$ is allowed at outer.)	10.2°~15°	$0.2 \leq \varnothing \leq 0.5\text{mm}$ ; $L \leq 1\text{mm}, W \leq 0.1\text{mm}$	$N \leq 5$	$N \leq 10$	$N \leq 15$	(0.4 $\leq \varnothing \leq 0.5\text{mm}$ , $N \leq 5$ is allowed at outer.)
		尺寸	缺圖	中心 Center	外圍 Outer	總數 Total	備註																															
All	$\varnothing < 0.2\text{mm}$ ;	不計數																																				
<6°	$0.2 \leq \varnothing \leq 0.3\text{mm}$ ; $L \leq 1\text{mm}, W \leq 0.1\text{mm}$	$N \leq 1$	$N \leq 2$	$N \leq 3$																																		
6~8°	$0.2 \leq \varnothing \leq 0.5\text{mm}$ ; $L \leq 1\text{mm}, W \leq 0.1\text{mm}$	$N \leq 2$	$N \leq 3$	$N \leq 5$	0.4 $\leq \varnothing \leq 0.5\text{mm}$ , $N \leq 1$ is allowed at outer.)																																	
8.1°~10.1°	$0.2 \leq \varnothing \leq 0.5\text{mm}$ ; $L \leq 1\text{mm}, W \leq 0.1\text{mm}$	$N \leq 2$	$N \leq 5$	$N \leq 7$	0.4 $\leq \varnothing \leq 0.5\text{mm}$ , $N \leq 2$ is allowed at outer.)																																	
10.2°~15°	$0.2 \leq \varnothing \leq 0.5\text{mm}$ ; $L \leq 1\text{mm}, W \leq 0.1\text{mm}$	$N \leq 5$	$N \leq 10$	$N \leq 15$	(0.4 $\leq \varnothing \leq 0.5\text{mm}$ , $N \leq 5$ is allowed at outer.)																																	

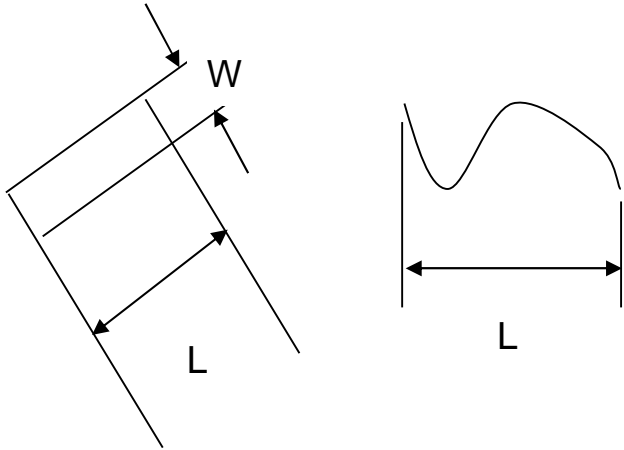
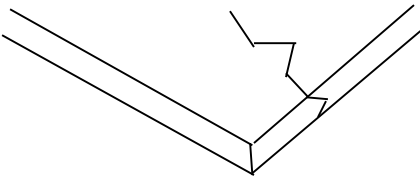
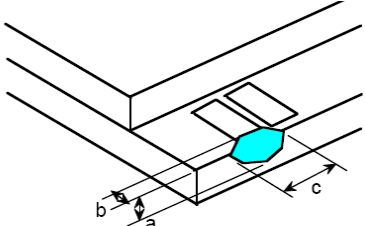
<p>04</p>	<p>Black and White Line Scratch Foreign Material (Line Type) (Minor Defect)</p>	 <table border="1" data-bbox="608 721 1235 983"> <thead> <tr> <th>Length</th> <th>Width</th> <th>Acc. Qty</th> </tr> </thead> <tbody> <tr> <td>/</td> <td><math>W \leq 0.1</math></td> <td>Ignore</td> </tr> <tr> <td><math>L \leq 2.5</math></td> <td><math>0.1 &lt; W \leq 0.2</math></td> <td>3</td> </tr> <tr> <td><math>L &gt; 2.5</math></td> <td><math>0.2 &lt; W</math></td> <td>0</td> </tr> <tr> <td colspan="2">Total</td> <td>3</td> </tr> </tbody> </table> <p>Distance between 2 defects should more than 3mm apart. Scratches not viewable through the back of the display are acceptable.</p>	Length	Width	Acc. Qty	/	$W \leq 0.1$	Ignore	$L \leq 2.5$	$0.1 < W \leq 0.2$	3	$L > 2.5$	$0.2 < W$	0	Total		3
Length	Width	Acc. Qty															
/	$W \leq 0.1$	Ignore															
$L \leq 2.5$	$0.1 < W \leq 0.2$	3															
$L > 2.5$	$0.2 < W$	0															
Total		3															
<p>05</p>	<p>Glass Crack (Minor Defect)</p>	 <p>Crack is potential to enlarge, any type is not allowed.</p>															
<p>06</p>	<p>Glass Chipping Pad Area: (Minor Defect)</p> 	<table border="1" data-bbox="863 1592 1334 1765"> <thead> <tr> <th>Length and Width</th> <th>Acc. Qty</th> </tr> </thead> <tbody> <tr> <td><math>c &gt; 3.0, b &lt; 1.0</math></td> <td>1</td> </tr> <tr> <td><math>c &lt; 3.0, b &lt; 1.0</math></td> <td>3</td> </tr> <tr> <td colspan="2"><math>a &lt; \text{Glass Thickness}</math></td> </tr> </tbody> </table>	Length and Width	Acc. Qty	$c > 3.0, b < 1.0$	1	$c < 3.0, b < 1.0$	3	$a < \text{Glass Thickness}$								
Length and Width	Acc. Qty																
$c > 3.0, b < 1.0$	1																
$c < 3.0, b < 1.0$	3																
$a < \text{Glass Thickness}$																	

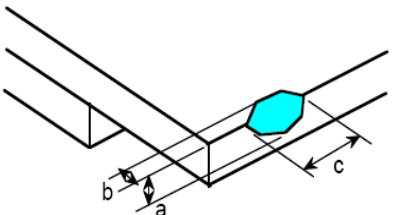
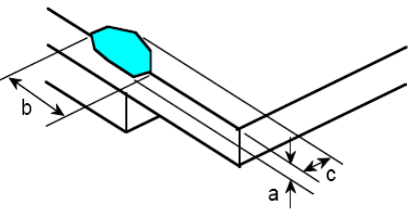
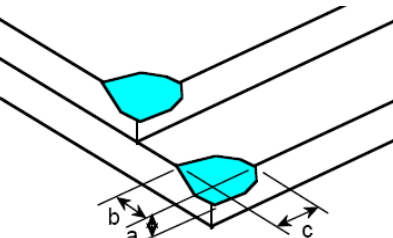
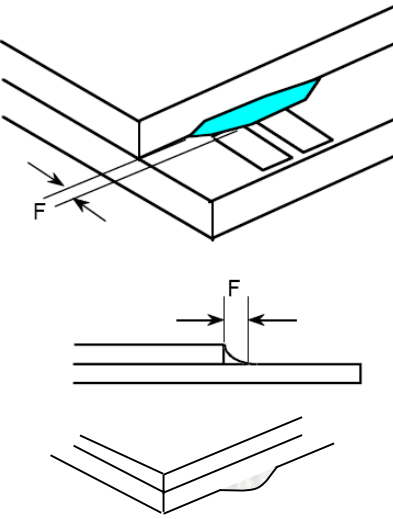
<p>07</p>	<p>Glass Chipping Rear of Pad Area: (Minor Defect)</p> 	<table border="1"> <thead> <tr> <th>Length and Width</th> <th>Acc. Qty</th> </tr> </thead> <tbody> <tr> <td><math>c &gt; 3.0, b &lt; 1.0</math></td> <td>1</td> </tr> <tr> <td><math>c &lt; 3.0, b &lt; 1.0</math></td> <td>2</td> </tr> <tr> <td><math>c &lt; 3.0, b &lt; 0.5</math></td> <td>4</td> </tr> <tr> <td colspan="2">a &lt; Glass Thickness</td> </tr> </tbody> </table>	Length and Width	Acc. Qty	$c > 3.0, b < 1.0$	1	$c < 3.0, b < 1.0$	2	$c < 3.0, b < 0.5$	4	a < Glass Thickness	
Length and Width	Acc. Qty											
$c > 3.0, b < 1.0$	1											
$c < 3.0, b < 1.0$	2											
$c < 3.0, b < 0.5$	4											
a < Glass Thickness												
<p>08</p>	<p>Glass Chipping Except Pad Area: (Minor Defect)</p> 	<table border="1"> <thead> <tr> <th>Length and Width</th> <th>Acc. Qty</th> </tr> </thead> <tbody> <tr> <td><math>c &gt; 3.0, b &lt; 1.0</math></td> <td>1</td> </tr> <tr> <td><math>c &lt; 3.0, b &lt; 1.0</math></td> <td>2</td> </tr> <tr> <td><math>c &lt; 3.0, b &lt; 0.5</math></td> <td>4</td> </tr> <tr> <td colspan="2">a &lt; Glass Thickness</td> </tr> </tbody> </table>	Length and Width	Acc. Qty	$c > 3.0, b < 1.0$	1	$c < 3.0, b < 1.0$	2	$c < 3.0, b < 0.5$	4	a < Glass Thickness	
Length and Width	Acc. Qty											
$c > 3.0, b < 1.0$	1											
$c < 3.0, b < 1.0$	2											
$c < 3.0, b < 0.5$	4											
a < Glass Thickness												
<p>09</p>	<p>Glass Corner Chipping: (Minor Defect)</p> 	<table border="1"> <thead> <tr> <th>Length and Width</th> <th>Acc. Qty</th> </tr> </thead> <tbody> <tr> <td><math>c &lt; 3.0, b &lt; 3.0</math></td> <td>Ignore</td> </tr> <tr> <td colspan="2">a &lt; Glass Thickness</td> </tr> </tbody> </table>	Length and Width	Acc. Qty	$c < 3.0, b < 3.0$	Ignore	a < Glass Thickness					
Length and Width	Acc. Qty											
$c < 3.0, b < 3.0$	Ignore											
a < Glass Thickness												
<p>10</p>	<p>Glass Burr: (Minor Defect)</p> 	<table border="1"> <thead> <tr> <th>Length</th> <th>Acc. Qty</th> </tr> </thead> <tbody> <tr> <td><math>F &lt; 1.0</math></td> <td>Ignore</td> </tr> </tbody> </table> <p>Glass burr don't affect assemble and module dimension.</p>	Length	Acc. Qty	$F < 1.0$	Ignore						
Length	Acc. Qty											
$F < 1.0$	Ignore											

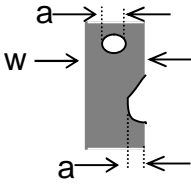
11	<p>FPC Defect: (Minor Defect)</p> 	<p>11.1 Dent, pinhole width <math>a &lt; w/3</math>. (w: circuitry width.) 11.2 Open circuit is unacceptable. 11.3 No oxidation, contamination and distortion.</p>								
12	<p>Bubble on Polarizer (Minor Defect)</p>	<table border="1" data-bbox="737 584 1209 757"> <thead> <tr> <th>Diameter</th> <th>Acc. Qty</th> </tr> </thead> <tbody> <tr> <td><math>\varphi \leq 0.30</math></td> <td>Ignore</td> </tr> <tr> <td><math>0.30 &lt; \varphi \leq 0.50</math></td> <td><math>N \leq 2</math></td> </tr> <tr> <td><math>0.50 &lt; \varphi</math></td> <td><math>N = 0</math></td> </tr> </tbody> </table>	Diameter	Acc. Qty	$\varphi \leq 0.30$	Ignore	$0.30 < \varphi \leq 0.50$	$N \leq 2$	$0.50 < \varphi$	$N = 0$
Diameter	Acc. Qty									
$\varphi \leq 0.30$	Ignore									
$0.30 < \varphi \leq 0.50$	$N \leq 2$									
$0.50 < \varphi$	$N = 0$									
13	<p>Dent on Polarizer (Minor Defect)</p>	<table border="1" data-bbox="737 837 1209 1010"> <thead> <tr> <th>Diameter</th> <th>Acc. Qty</th> </tr> </thead> <tbody> <tr> <td><math>\varphi \leq 0.25</math></td> <td>Ignore</td> </tr> <tr> <td><math>0.25 &lt; \varphi \leq 0.50</math></td> <td><math>N \leq 4</math></td> </tr> <tr> <td><math>0.50 &lt; \varphi</math></td> <td>None</td> </tr> </tbody> </table>	Diameter	Acc. Qty	$\varphi \leq 0.25$	Ignore	$0.25 < \varphi \leq 0.50$	$N \leq 4$	$0.50 < \varphi$	None
Diameter	Acc. Qty									
$\varphi \leq 0.25$	Ignore									
$0.25 < \varphi \leq 0.50$	$N \leq 4$									
$0.50 < \varphi$	None									
14	<p>Bezel</p>	<p>14.1 No rust, distortion on the Bezel. 14.2 No visible fingerprints, stains or other contamination.</p>								
15	<p>Touch Panel</p>	<p>D: Diameter W: width L: length 15.1 Spot: <math>D &lt; 0.25</math> is acceptable <math>0.25 \leq D \leq 0.4</math> 2dots are acceptable and the distance between defects should more than 10 mm. <math>D &gt; 0.4</math> is unacceptable 15.2 Dent: <math>D &gt; 0.40</math> is unacceptable 15.3 Scratch: <math>W \leq 0.03</math>, <math>L \leq 10</math> is acceptable, <math>0.03 &lt; W \leq 0.10</math>, <math>L \leq 10</math> is acceptable Distance between 2 defects should more than 10 mm. <math>W &gt; 0.10</math> is unacceptable.</p>								
16	<p>PCB</p>	<p>16.1 No distortion or contamination on PCB terminals. 16.2 All components on PCB must same as documented on the BOM/component layout. 16.3 Follow IPC-A-600F.</p>								
17	<p>Soldering</p>	<p>Follow IPC-A-610C standard</p>								

18	Electrical Defect (Major Defect)	<p>The below defects must be rejected.</p> <p>18.1 Missing vertical / horizontal segment,</p> <p>18.2 Abnormal Display.</p> <p>18.3 No function or no display.</p> <p>18.4 Current exceeds product specifications.</p> <p>18.5 LCD viewing angle defect.</p> <p>18.6 No Backlight.</p> <p>18.7 Dark Backlight.</p> <p>18.8 Touch Panel no function.</p>
----	-------------------------------------	---

Remark: LCD Panel Broken shall be rejected. Defect out of LCD viewing area is acceptable.

**10.7. Classification of Defects**

- 10.7.1. Visual defects (Except no / wrong label) are treated as minor defect and electrical defect is major.
- 10.7.2. Two minor defects are equal to one major in lot sampling inspection.

**10.8. Identification/marketing criteria**

Any unit with illegible / wrong /double or no marking/ label shall be rejected.

**10.9. Packing**

- 10.9.1. There should be no damage of the outside carton box, each packaging box should have one identical label.
- 10.9.2. Modules inside package box should have compliant mark.
- 10.9.3. All direct package materials shall offer ESD protection.

**Note1:** Bright dot is defined as the defective area of the dot is larger than 50% of one sub-pixel area.

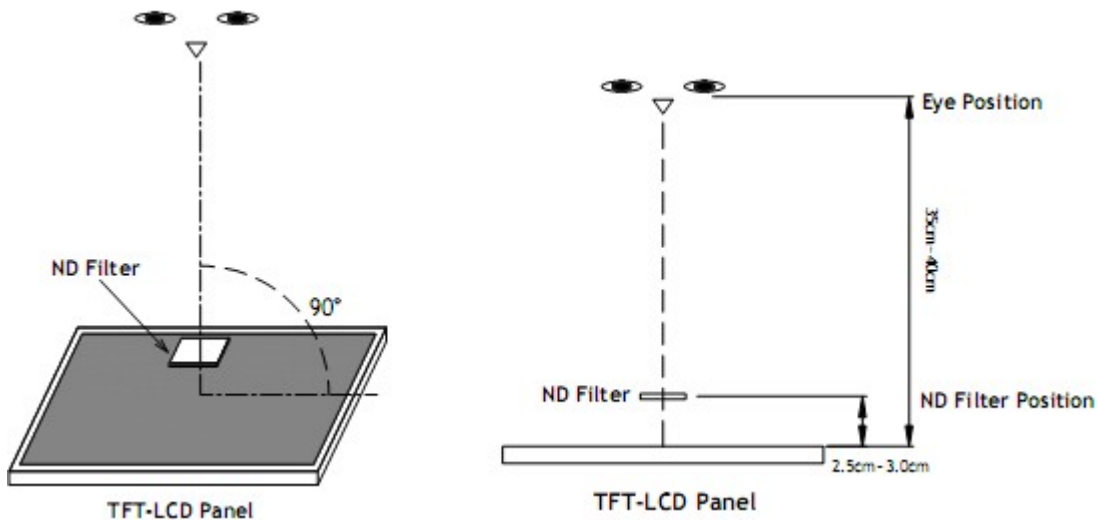

Bright dot: The bright dot size defect at black display pattern. It can be recognized by 2% transparency of filter when the distance between eyes and panel is 350mm± 50mm.

Dark dot: Cyan, Magenta or Yellow dot size defect at white display pattern. It can be recognized by 5% transparency of filter when the distance between eyes and panel is 350mm± 50mm.

**Note2:** Mura on display which appears darker / brighter against background brightness on parts of display area.

**11. Reliability Specification**

No	Item	Condition	Quantity	Criteria
1	High Temperature Operating	70°C, 96Hrs	2	GB/T2423.2-2008
2	Low Temperature Operating	-20°C, 96Hrs	2	GB/T2423.1-2008
3	High Humidity Storage	50°C, 90%RH, 96Hrs	2	GB/T2423.3-2016
4	High Temperature Storage	80°C, 96Hrs	2	GB/T2423.2-2008
5	Low Temperature Storage	-30°C, 96Hrs	2	GB/T2423.1-2008
6	Thermal Cycling Test Storage	-20°C, 60min~70°C, 60min, 20 cycles.	2	GB/T2423.22-2012
7	Packing vibration	Frequency range:10Hz~50Hz Acceleration of gravity:5G X, Y, Z 30 min for each direction.	2	GB/T5170.14-2009
8	Electrical Static Discharge	Air: ± 8kV 150pF/330 Ω 5 times Contact: ± 4kV 150pF/330 Ω 5 times	2	GB/T17626.2-2018
9	Drop Test (Packaged)	Height:80 cm,1 corner, 3 edges, 6 surfaces.	2	GB/T2423.8-1995

Note1. No deflection cosmetic and operational function allowable.

Note2. Total current Consumption should be below double of initial value

**12. Precautions and Warranty**

**12.1. Safety**

- 12.1.1. The liquid crystal in the LCD is poisonous. Do not put it in your mouth. If the liquid crystal touches your skin or clothes, wash it off immediately using soap and water.
- 12.1.2. Since the liquid crystal cells are made of glass, do not apply strong impact on them. Handle with care.

**12.2. Handling**

- 12.2.1. Reverse and use within ratings in order to keep performance and prevent damage.
- 12.2.2. Do not wipe the polarizer with dry cloth, as it might cause scratch. If the surface of the LCD needs to be cleaned, wipe it swiftly with cotton or other soft cloth soaked with petroleum IPA, do not use other chemicals.

**12.3. Storage**

- 12.3.1. Do not store the LCD module beyond the specified temperature ranges.
- 12.3.2. Strong light exposure causes degradation of polarizer and color filter.

**12.4. Metal Pin (Apply to Products with Metal Pins)**

12.4.1. Pins of LCD and Backlight

12.4.1.1. Solder tip can touch and press on the tip of Pin LEAD during the soldering

12.4.1.2. Recommended Soldering Conditions

Solder Type: Sn96.3~94-Ag3.3~4.3-Cu0.4~1.1

Maximum Solder Temperature: 370°C

Maximum Solder Time: 3s at the maximum temperature

Recommended Soldering Temp: 350±20°C

Typical Soldering Time: ≤3s

12.4.1.3. Solder Wetting

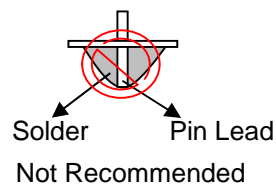
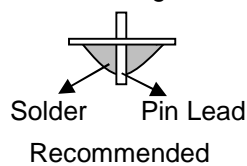

12.4.2. Pins of EL

12.4.2.1. Solder tip can touch and press on the tip of EL leads during soldering.

12.4.2.2. No Solder Paste on the soldering pad on the motherboard is recommended.

12.4.2.3. Recommended Soldering Conditions

Solder type: Nippon Alimit Leadfree SR-34, size 0.5mm

Recommended Solder Temperature: 270~290°C

Typical Soldering Time: ≤2s

Minimum solder distance from EL lamp (body):2.0mm

12.4.2.4. No horizontal press on the EL leads during soldering.

12.4.2.5. 180° bend EL leads three times is not allowed.

12.4.2.6. Solder Wetting

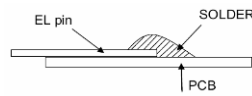

Recommended

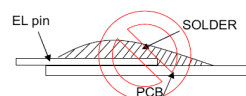

Not Recommended

12.4.2.7. The type of the solder iron:

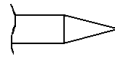

Recommended

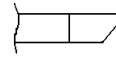

Not Recommended

12.4.2.8. Solder Pad

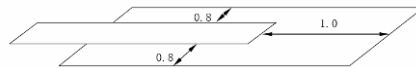

**12.5.Operation**

- 12.5.1. Do not drive LCD with DC voltage
- 12.5.2. Response time will increase below lower temperature
- 12.5.3. Display may change color with different temperature
- 12.5.4. Mechanical disturbance during operation, such as pressing on the display area, may cause the segments to appear “fractured”.
- 12.5.5. Do not connect or disconnect the LCM to or from the system when power is on.
- 12.5.6. Never use the LCM under abnormal condition of high temperature and high humidity.
- 12.5.7. Module has high frequency circuits. Sufficient suppression to the electromagnetic interface shall be done by system manufacturers. Grounding and shielding methods may be important to minimize the interference.
- 12.5.8. Do not display the fixed pattern for long time (we suggest the time not longer than one hour) because it may develop image sticking due to the TFT structure.

**12.6.Static Electricity**

- 12.6.1. CMOS LSIs are equipped in this unit, so care must be taken to avoid the electro-static charge, by ground human body, etc.
- 12.6.2. The normal static prevention measures should be observed for work clothes and benches.
- 12.6.3. The module should be kept into anti-static bags or other containers resistant to static for storage.

**12.7.Limited Warranty**

- 12.7.1. Our warranty liability is limited to repair and/or replacement. We will not be responsible for any consequential loss.
- 12.7.2. If possible, we suggest customer to use up all modules in six months. If the module storage time over twelve months, we suggest that recheck it before the module be used.
- 12.7.3. After the product shipped, any product quality issues must be feedback within three months, otherwise, we will not be responsible for the subsequent or consequential events.



13. Outline Drawing

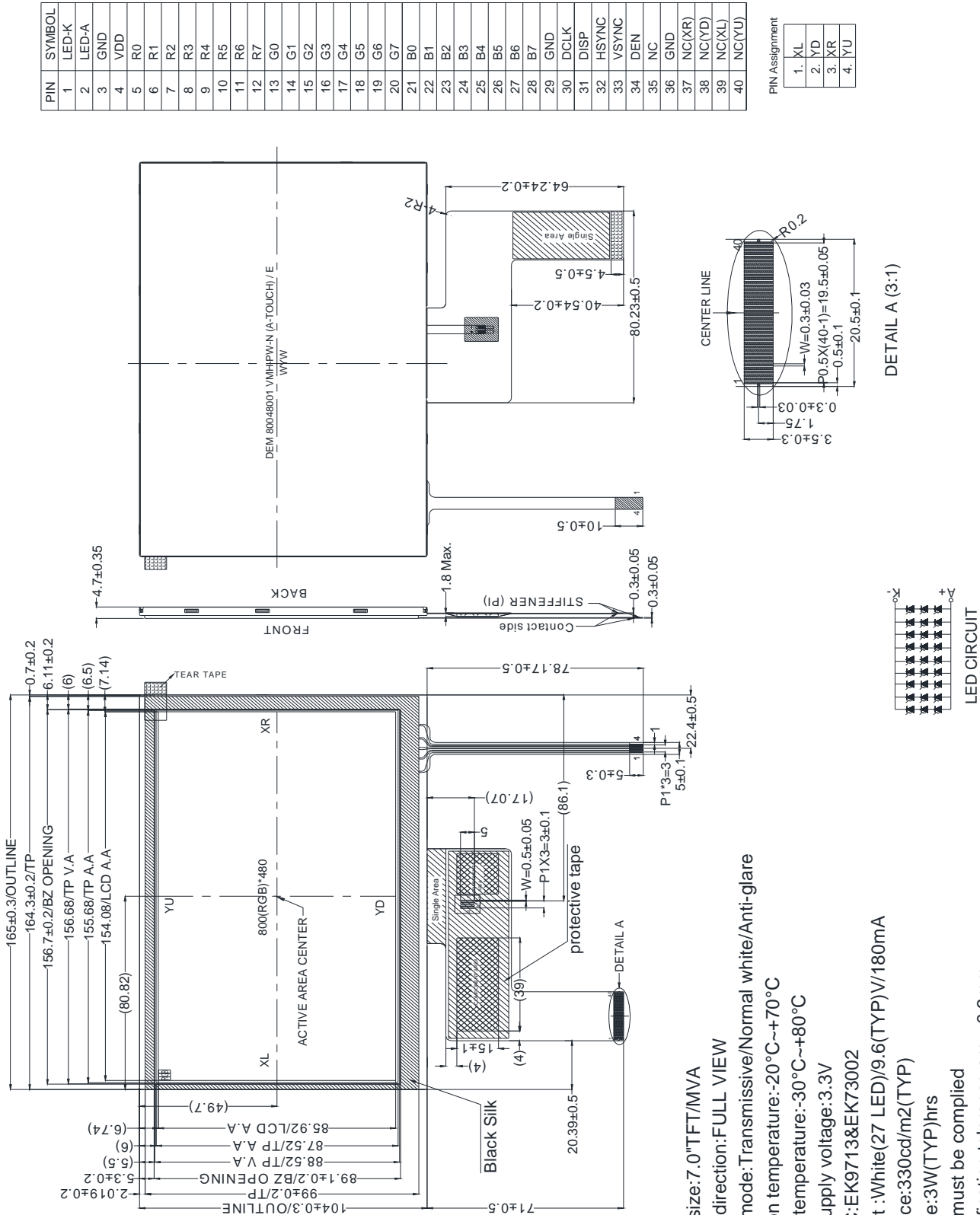

PIN	SYMBOL
1	LED-K
2	LED-A
3	GND
4	VDD
5	R0
6	R1
7	R2
8	R3
9	R4
10	R5
11	R6
12	R7
13	G0
14	G1
15	G2
16	G3
17	G4
18	G5
19	G6
20	G7
21	B0
22	B1
23	B2
24	B3
25	B4
26	B5
27	B6
28	B7
29	GND
30	DCLK
31	DISP
32	HSYNC
33	VSYNC
34	DEN
35	NC
36	GND
37	NC(XR)
38	NC(YD)
39	NC(XL)
40	NC(YU)

PIN Assignment

1.	XL
2.	YD
3.	XR
4.	YU

- NOTES:
1. Display size: 7.0" TFT/MVA
  2. Viewing direction: FULL VIEW
  3. Display mode: Transmissive/Normal white/Anti-glare
  4. Operation temperature: -20°C ~ +70°C
  5. Storage temperature: -30°C ~ +80°C
  6. Power supply voltage: 3.3V
  7. Driver IC: EK9713&EK73002
  8. Backlight : White(27 LED)/9.6(TYP)V/180mA
  9. Luminance: 330cd/m2(TYP)
  10. Life time: 3W(TYP)hrs
  11. ROHS must be complied
- \* Unspecification tolerance are ±0.3mm  
 \* The dimension with mark brackets "( )" just for reference