



Elektrotechnik Karl-Heinz Mauz GmbH

LSF-S2509A (Artikel-Nr. 106120)

EKULIT

1. Product Outline	
1-1. Scope	This specification is a typical speaker unit for telephone handset & tablet pc
1-2. Dimensions	As shown in figure 1
1-3. Net Weight	Approx 2.4grams
1-4. Operating Temperature Range	-20°C to +70°C without loss of function
1-5. Storage Temperature Range	-40°C to +85°C (Note: Return to ambient room temperature before using)
2. Electroacoustic Characteristics	
2-1. Test Setup	Measuring instrument as shown in Figure 2
2-2. Impedance	DC: $7.5 \pm 15\%$ ohm AC: $8 \pm 15\%$ ohm (at 2.0 KHz, 1V input)
2-3. Sound Pressure Level	94 ± 3 dB SPL /1.0W/10cm at 2kHz in 1.0cc box Speaker shall be mounted in a baffle with minimum dimensions of 80cm x 100cm. See Figure 3.
2-4. Frequency Response	See Figure 4, Table 1 Test at 2.83Vrms/10 cm with the speaker mounted in 1.0cc measure box in a baffle.
2-5. Bass Resonance Frequency	$850 \pm 15\%$ Hz in 1.0cc box
2-6. Input Power (Rated./Max.)	Rated Power: 1.0W (in 1.0cc box) Maximum Power: 1.5W (in 1.0cc box)
2-7. Rub and Buzz:	The input power shall be set at 1.0W. Using an audio oscillator, sweep from 300 to 4000 Hz with the speaker mounted in 1.0cc measure box and in a baffle. There shall be no buzzes, rattles, nor spurious noises.
2-8. THD	See Figure 5, Table 2 Test at 2.83Vrms/10 cm with the speaker mounted in 1.0cc measure box in a baffle.
2-9. Polarity	When a DC source's "+" polarity is attached to speaker's "+" polarity, "-" polarity is attached speaker's "-" polarity, the membrane will move forward.

Adresse: **Felix-Wankel-Str. 35 • 73760 Ostfildern/Nellingen**

Tel: **+49-711/3414023**

Fax: **+49-711/3414024**

E-mail: **info@ekulit.de** Web site: www.EKULIT.de



Elektrotechnik Karl-Heinz Mauz GmbH

LSF-S2509A (Artikel-Nr. 106120)

EKULIT

3. General Reliability	
3-1 General	After any following tests the response at 1 KHz shall not deviate more than ± 3 dB from the initial value
3-1 Temperature Shock Test	<p>Temperature: $-40^{\circ}\pm 3^{\circ}\text{C}$ \longleftrightarrow $+85^{\circ}\pm 3^{\circ}\text{C}$ Cycle: 10 cycles Duration: 1 hour 1 hour (recovery 2 hours)</p> <p>(30minutes) (5minutes) 1 cycle (5minutes)</p>
3-2 Static Humidity Test	Precondition at $+25^{\circ}\text{C}$ for 1 hour. Next expose samples to $+55^{\circ}\text{C}$ with 95% relative humidity for 96 hours with no bias. Finally allow test samples to dry at room ambient temperature for 3 ± 1 hour before taking final measurements.
3-3 Vibration Test	Secure device using a fixture appropriate for this test. Fixture shall be capable of mounting on vibration table. Vibrate from 10Hz to 2000Hz, 1 octave per minute, 2mm displacement $\pm x$, $\pm y$, $\pm z$ directions with 15 g's force for 2 hrs per each plane.
3-4 Drop Test	Drop samples 1.5 meters three times in each direction along each of the three mutually perpendicular axes for a total of 18 shocks. (Samples shall be mounted in a 100g fixture)
3-5 Operating Life Test	1.0cc box; 25°C ; Pink noise; 20Hz-20kHz; 1.0W; Crest factor 3-4; 96 H
3-6. Rated Sweep Power Test	1.0cc box; 25°C ; Rated Power(1.0W); 600-1000Hz; 1 sec; 12 H
3-7 Max Power Test	1.0cc box; 25°C ; Pink noise; 20Hz-20kHz; 1.5W; 1 sec on/60 sec off; 60 cycles
3-8. High Temperature Test	$85 \pm 2^{\circ}\text{C}$; 96H; 2H Recovery time
3-9. Low Temperature Test	$-40 \pm 2^{\circ}\text{C}$; 96H; 2H Recovery time

Adresse: Felix-Wankel-Str. 35 • 73760 Ostfildern/Nellingen

Tel: +49-711/3414023

Fax: +49-711/3414024

E-mail: info@ekulit.de Web site: www.EKULIT.de

LSF-S2509A (Artikel-Nr. 106120)

EKULIT

4. Mechanical Layout and Dimensions

4.1 Mechanical Layout

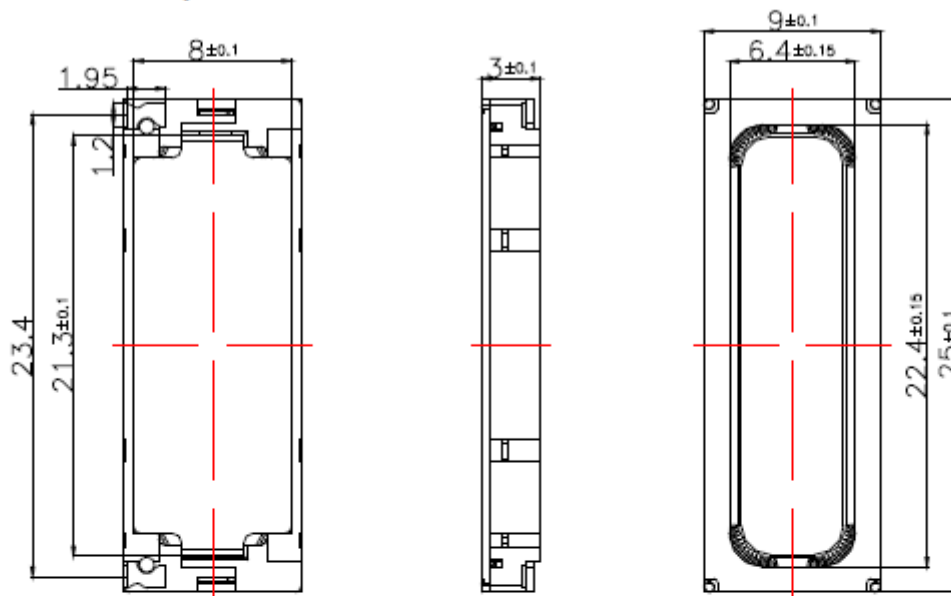

Notes:

1. General unless otherwise noted $\pm 0.15\text{mm}$.

(Figure 1)

8	PAD	Stainless Steel	2	
7	Cover	Plastic	1	
6	Voice Coil	Copper	1	
5	Diaphragm	Polymer	1	
4	Pole Piece	Iron	3	
3	Magnet	NdFeB	3	
2	Yoke	Iron	1	
1	Frame	Plastic	1	
No.	Part Name	Material	Q'TY	Remark

LSF-S2509A (Artikel-Nr. 106120)

EKULIT

4.2 Permitted Force to Speaker

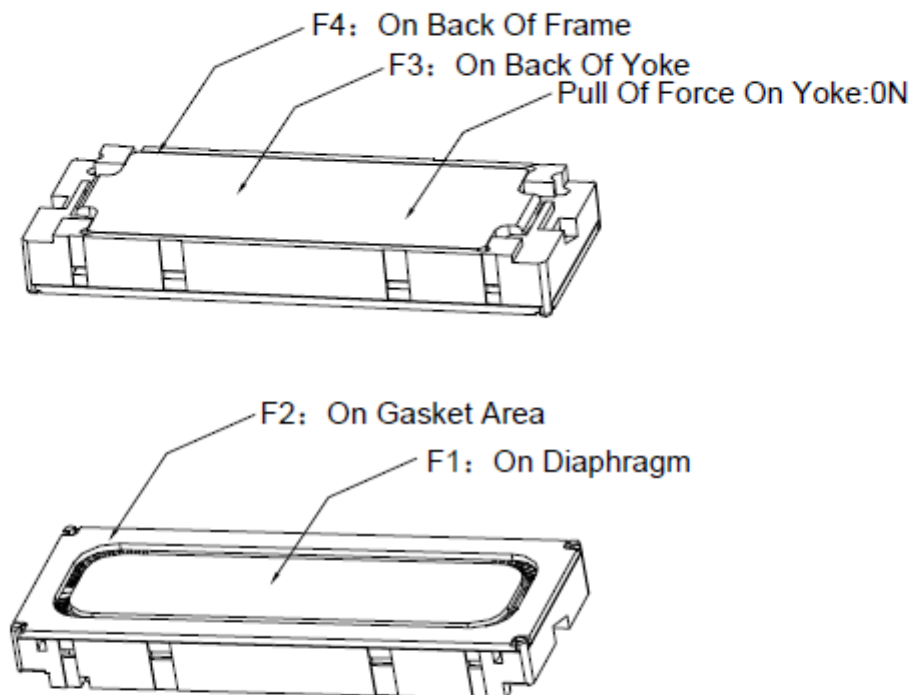

Max. Permitted Compression Forces			
No.	From	To	Maxmum Force
1	F1		0N
2	F3	F2	10N
3	F4	F2	10N

LSF-S2509A (Artikel-Nr. 106120)

EKULIT

5. Measuring Setup

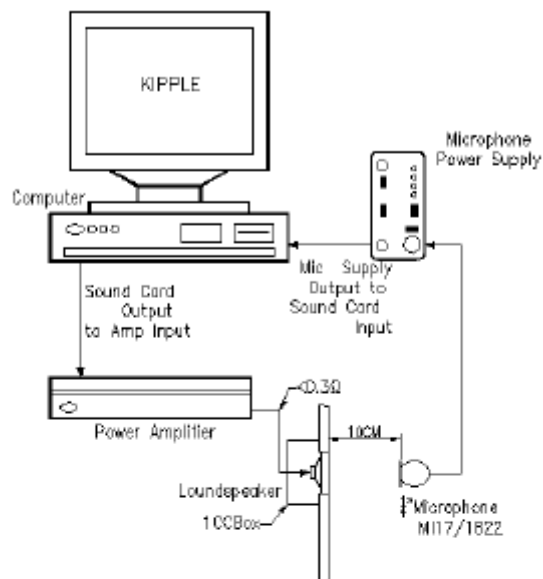

(Figure 2)

Baffle

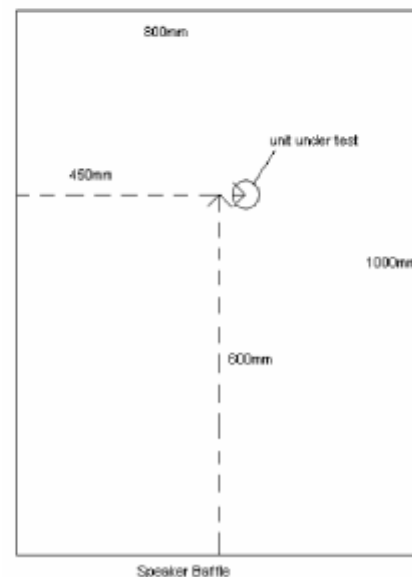

(Figure 3)

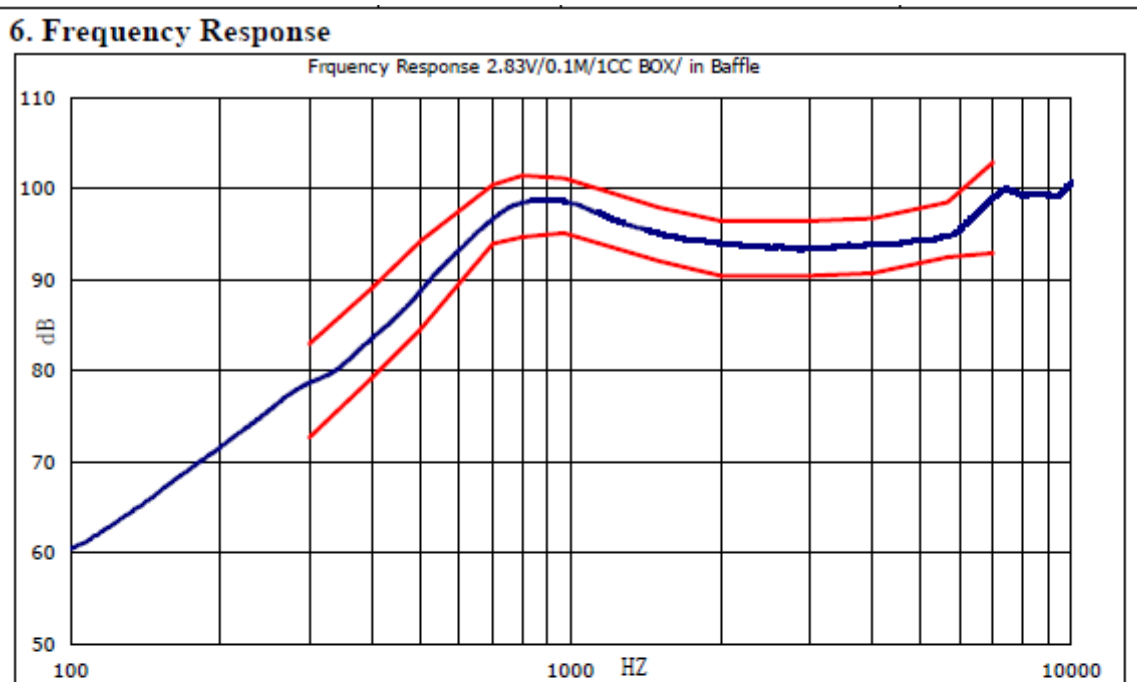

(Figure 4)

Table 1: Tolerance Limits Date for FR

Frequency(Hz)	Upper Limits(dB)	Frequency(Hz)	Lower Limits(dB)
300	82.9	300	72.6
400	89.1	400	79.2
500	94.2	500	84.5
700	100.5	700	94
800	101.5	800	94.7
970	101.2	970	95.2
1500	98	1500	92
2000	96.5	2000	90.5
3000	96.5	3000	90.5
4000	96.8	4000	90.8
5662	98.5	5662	92.5
7000	102.9	7000	92.9



Elektrotechnik Karl-Heinz Mauz GmbH

LSF-S2509A (Artikel-Nr. 106120)

EKULIT

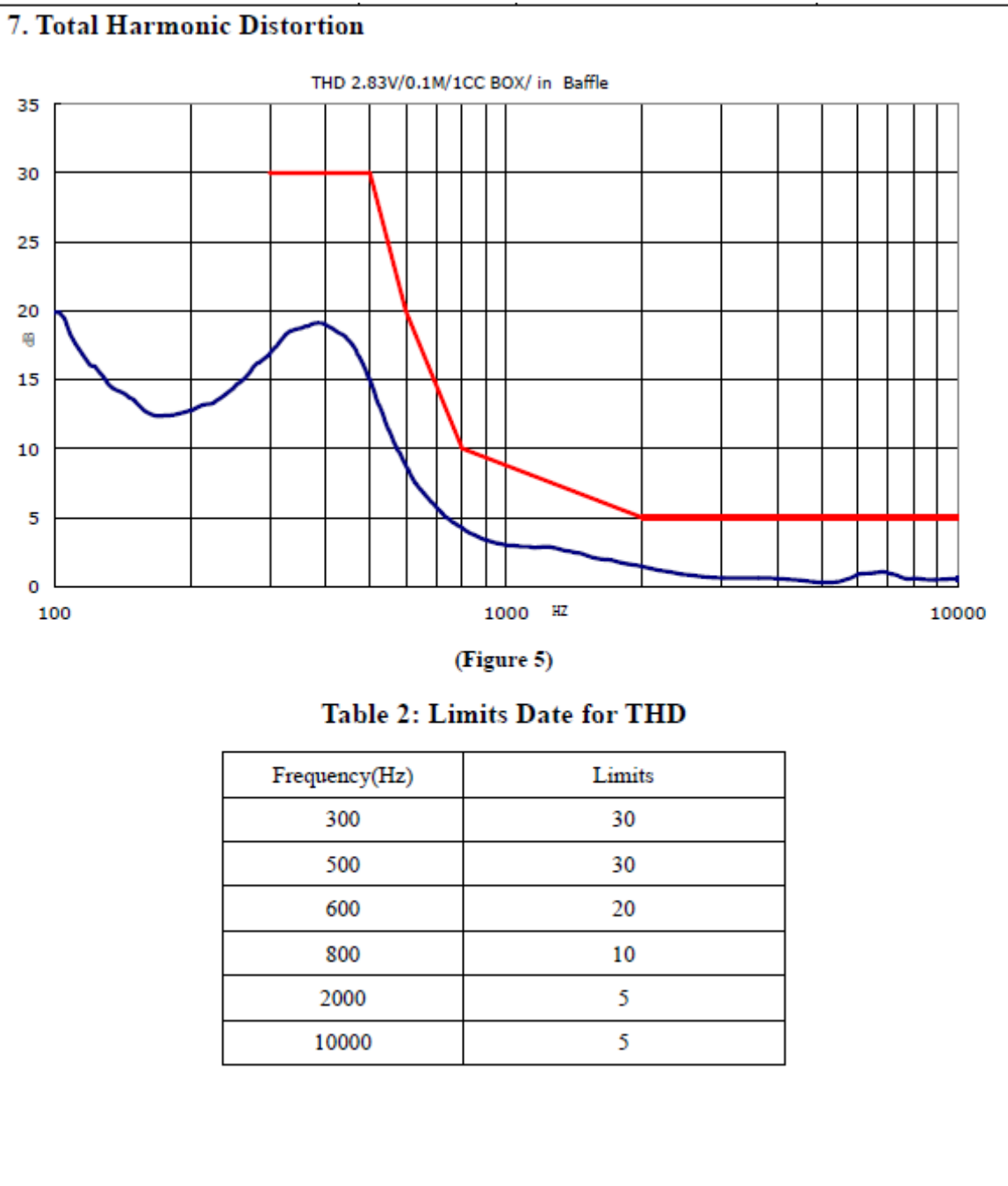

Adresse: Felix-Wankel-Str. 35 • 73760 Ostfildern/Nellingen

Tel: +49-711/3414023

Fax: +49-711/3414024

E-mail: info@ekulit.de Web site: www.EKULIT.de

8. Application Note

1. Air tight is needed between front cover of speaker and housing, otherwise cause audio performance's losing, such as higher THD, lower sensitivity;
2. Tiny air leakage in back of speaker is permitted to keep balance of air pressure;
3. For this speaker, the standard power is 1.0W in 1.0cc back cavity, when the back cavity is less or more than the standard volume of back cavity, the handling power also will be changed. See below figure about the relationship between power handling and back volume, here the power is excursion limited power; the thermal power should be evaluated, especially in small back cavity, such as 0.5cc. And the recommend minimum back volume is 0.5cc.
4. If the power higher than 1W input the speaker in standard back cavity, there is the risk of damaging speaker. In case of the back volume larger than 1.0cc, i.e. 2cc, the power handing of the speaker is pretty low. To maintain the rated power as 1.0W, we suggest adding thicker mesh with more acoustic resistance on the cover to reduce the vibration amplitude, or using electric filter to attenuate the maximum vibration amplitude.

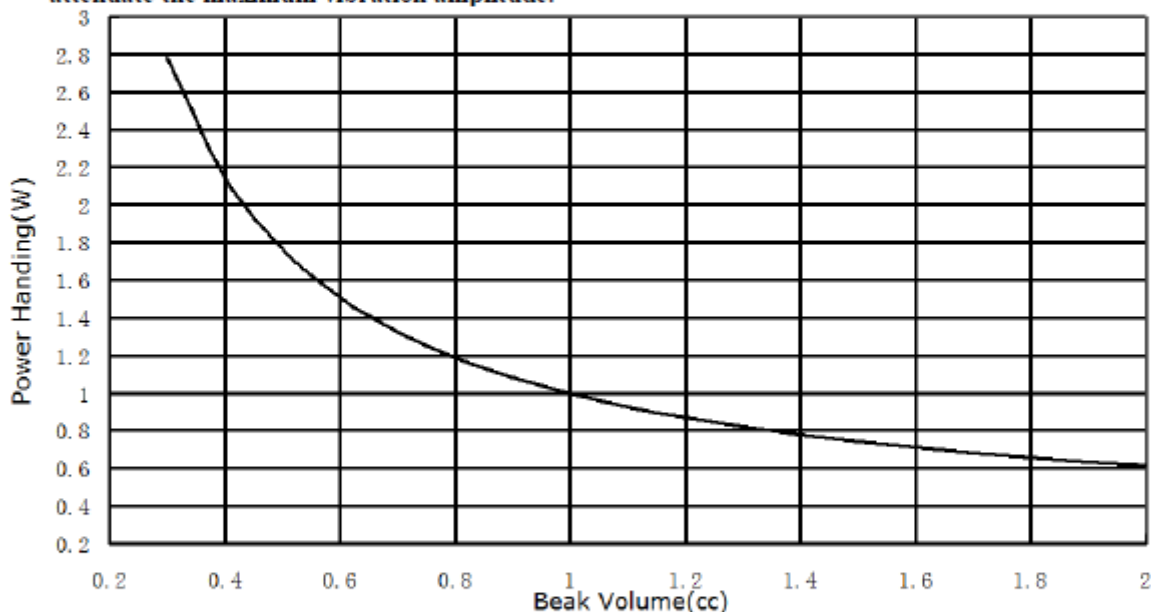

(Figure 6)

8. Application Note

1. Air tight is needed between front cover of speaker and housing, otherwise cause audio performance's losing, such as higher THD, lower sensitivity;
2. Tiny air leakage in back of speaker is permitted to keep balance of air pressure;
3. For this speaker, the standard power is 1.0W in 1.0cc back cavity, when the back cavity is less or more than the standard volume of back cavity, the handling power also will be changed. See below figure about the relationship between power handling and back volume, here the power is excursion limited power; the thermal power should be evaluated, especially in small back cavity, such as 0.5cc. And the recommend minimum back volume is 0.5cc.
4. If the power higher than 1W input the speaker in standard back cavity, there is the risk of damaging speaker. In case of the back volume larger than 1.0cc, i.e. 2cc, the power handing of the speaker is pretty low. To maintain the rated power as 1.0W, we suggest adding thicker mesh with more acoustic resistance on the cover to reduce the vibration amplitude, or using electric filter to attenuate the maximum vibration amplitude.

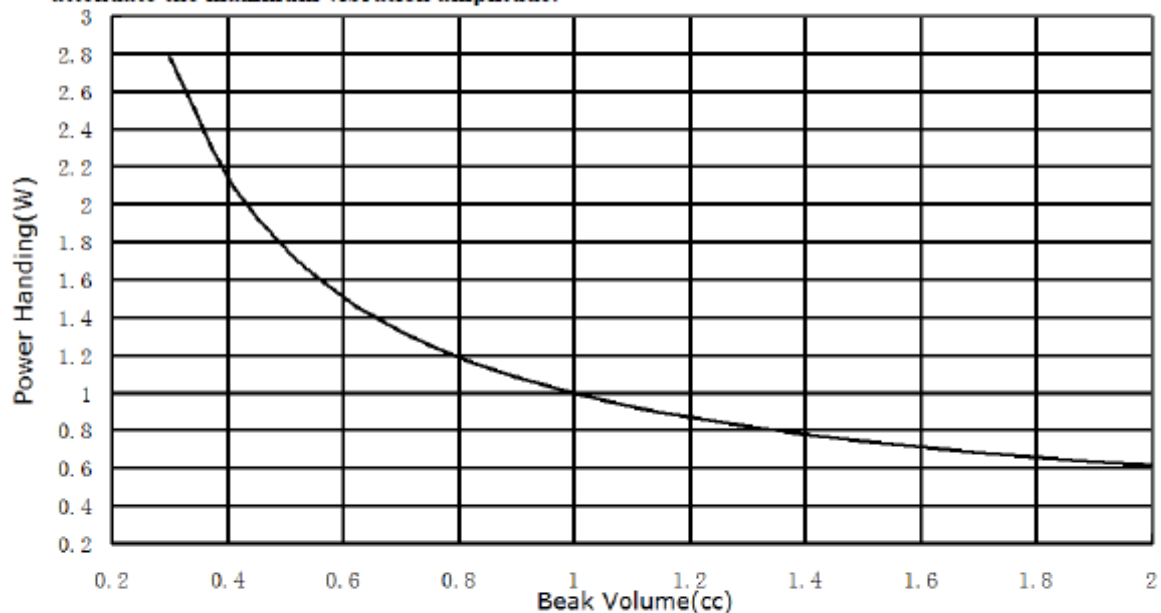

(Figure 6)

LSF-S2509A (Artikel-Nr. 106120)

EKULIT

9. Resonance frequency VS sealed back volume

The resonance frequency of the speaker box will vary with different sealed back volume.

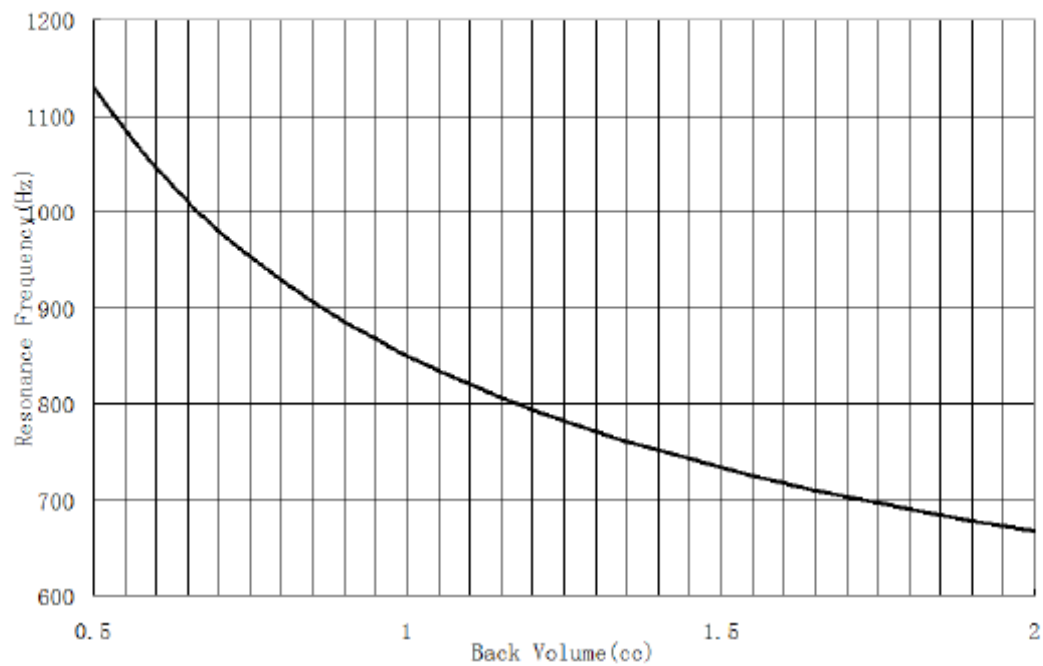

(Figure 7)

10. T/S parameters

Thiele-Small Parameters: The following Thiele-Small Parameters are guidelines from a speaker exhibiting good audio performance.

Fs	430	Hz
Re	7.3	ohm
Sd	1.52	cm ²
Bl	1.02	T.m
Vas	3.3	cc
Cms	1.014	mm/N
Mms	133	mg
Qms	2.25	
Qes	1.86	
Qt	1.01	



Elektrotechnik Karl-Heinz Mauz GmbH

LSF-S2509A (Artikel-Nr. 106120)

EKULIT

11. Peak to peak excursion Amplitude
Xp (mm) at different Frequency rated power

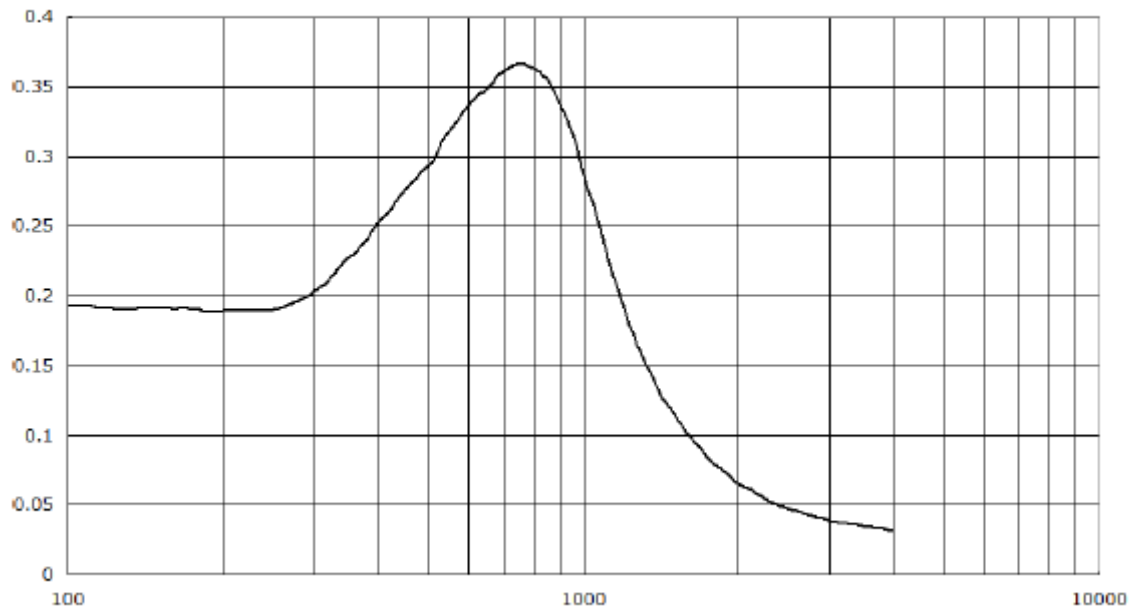

(Figure 8)

Adresse: **Felix-Wankel-Str. 35 • 73760 Ostfildern/Nellingen**

Tel: **+49-711/3414023**

Fax: **+49-711/3414024**

E-mail: **info@ekulit.de** Web site: www.EKULIT.de

LSF-S2509A (Artikel-Nr. 106120)

EKULIT

12. Package

- 1、 100pcs of speaker in each tray
- 2、 20 trays in one carton
- 3、 Total:2000 pcs / 1 carton
- 4、 Gross Weight:6.8KGS
- 5、 Net Weight: 4.8KGS

