

Display Elektronik GmbH

DATA SHEET

TFT MODULE

DEM 800480V VMH-PW-N

4,3" TFT

Product Specification

Ver.: 2

12.09.2019

Revision History

Revision	Date	Originator	Detail	Remarks
0	18.09.2018	MH	Initial Release	-
1	29.11.2018	MH	Add Weight Add Chromacity Transmissive	-
2	12.09.2019	MHI	Modify Luminance on TFT Modify Criteria Modify Outline Drawing	-

Table of Contents

No.	Item	Page
1.	General Description	4
2.	Module Parameter.....	4
3.	Absolute Maximum Ratings	4
4.	DC Characteristics	5
5.	Backlight Characteristics.....	5
5.1.	Backlight Characteristics	5
5.2.	Backlighting circuit	5
6.	Optical Characteristics	6
6.1.	Optical Characteristics.....	6
6.2.	Definition of Response Time.....	6
6.3.	Definition of Contrast Ratio.....	7
6.4.	Definition of Viewing Angles	7
6.5.	Definition of Color Appearance	8
6.6.	Definition of Surface Luminance, Uniformity and Transmittance.....	8
7.	Block Diagram and Power Supply	9
8.	Interface Pins Definition	10
9.	AC Characteristics.....	12
10.	Power on/off Sequence.....	14
11.	Quality Assurance	15
11.1.	Purpose	15
11.2.	Standard for Quality Test.....	15
11.3.	Nonconforming Analysis & Disposition	15
11.4.	Agreement Items	15
11.5.	Standard of the Product Visual Inspection	16
11.6.	Inspection Specification	16
11.7.	Classification of Defects.....	20
11.8.	Identification/marketing criteria	20
11.9.	Packaging	21
12.	Reliability Specification	22
13.	Precautions and Warranty.....	23
13.1.	Safety.....	23
13.2.	Handling.....	23
13.3.	Storage.....	23
13.4.	Metal Pin (Apply to Products with Metal Pins).....	23
13.5.	Operation	24
13.6.	Static Electricity.....	24
13.7.	Limited Warranty.....	24
14.	Outline Drawing.....	25

1. General Description

The specification is a transmissive type color active matrix liquid crystal display (LCD) which uses amorphous thin film transistor (TFT) as switching devices. This product is composed of a TFT-LCD panel, driver ICs and a backlight unit.

2. Module Parameter

Features	Details	Unit
Display Size (Diagonal)	4.3"	-
LCD Type	a-Si (IPS) TFT	-
Display Mode	Normally Black / Transmissive	-
Resolution	800 x RGB x 480	Pixels
View Direction	FULL VIEW	Best Image
Module Outline	105.50 x 67.20 x 2.70	mm
Active Area	95.04 x 53.86	mm
Pixel Size	0.1188 x 0.1122	mm
Pixel Arrangement	R.G.B Vertical Stripe	-
Polarizer Surface Treatment	Glare Type	-
Display Colors	16.7 Million	-
Driver IC	HX8264-D & HX8664-B (HIMAX)	-
Interface	24-Bit RGB-Interface, 18-Bit-RGB-Interface	-
With or Without Touch Panel	Without	-
Operating Temperature	-20°C to +80°C	°C
Storage Temperature	-30°C to +85°C	°C
Weight	~ 39	g

Note 1: Exclusive hooks, posts, FFC/FPC tail etc.

3. Absolute Maximum Ratings

V_{SS}=0V, Ta=25°C

Item	Symbol	Min.	Max.	Unit
Supply Voltage	DVDD	-0.5	+3.96	V
	AVDD	-0.5	+14.85	V
	VGH	-0.3	42	V
	VGL	VGH-42	0.3	V
Storage Temperature	T _{STG}	-30	85	°C
Operating Temperature	T _{OP}	-20	80	°C

Note 1: If Ta below 50°C, the maximal Humidity is 90%RH, if Ta over +50°C, absolute Humidity should be less than 60%RH.

Note 2: The Response Time will be extremely slow when the Operating Temperature is around -10°C, and the Background will become darker at High Temperature operating.

4. DC Characteristics

Item	Symbol	Min.	Typ.	Max.	Unit
Supply Voltage	VDD	2.7	3.3	3.6	V
	AVDD	(6.5)	-	(13.5)	V
	VGH	-	(15)	-	V
	VGL	-	(-10)	-	V
	VCOM	(3.1)	-	(5.1)	V
Logic Low Input Voltage	V _{IL}	0	-	0.3*DVDD	V
Logic High Input Voltage	V _{IH}	0.7*DVDD	-	DVDD	V
Output Low Voltage	V _{OL}	-	-	VSS+0.4	V
Output High Voltage	V _{OH}	DVDD-0.4	-	-	V

Note 1: Typical VCOM is only a reference value. It must be optimized according to each LCM. Please use VR and base on below application circuit.

5. Backlight Characteristics

5.1. Backlight Characteristics

Item	Symbol	Condition	Min.	Typ.	Max.	Unit
Backlight Voltage	V _{LED}	T _a =25°C, I _F =20mA/LED	16.8	19.2	20.4	V
Backlight Current	I _{LED}	T _a =25°C, V _F =3.2V/LED	-	40	-	mA
Power Dissipation	P _D		-	768	-	mW
Uniformity	Avg		-	80	-	%
LED Lifetime (+25°C)	-		20000	30000	-	Hrs
Drive Method	Constant Current					
LED Configuration	12 White LEDs (6 LEDs in one string and 2 groups in parallel)					

Note1: LED Lifetime defined as follows: The final brightness is at 50% of original brightness.
 The environmental conducted under ambient air flow,
 at T_a=25°C ± 2°C, 60%RH ± 5%, I_F=20mA/LED.

5.2. Backlighting Circuit

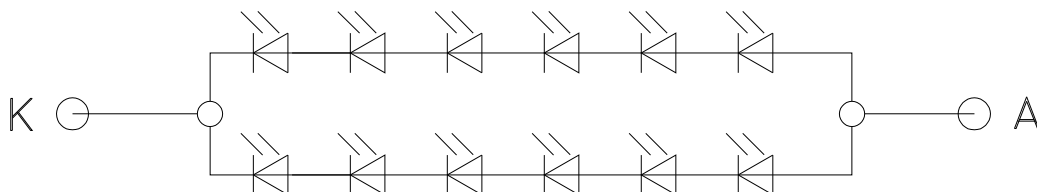

6. Optical Characteristics

6.1. Optical Characteristics

Ta=25°C, DVDD=3.3V

	Item	Symbol	Condition	Specification			Unit	
				Min.	Typ.	Max.		
Backlight On (Transmissive Mode)	Luminance on TFT ($I_f = 20\text{mA/LED}$)	Lv	Normally viewing angle $\theta_x = \phi_y = 0^\circ$	480	600	-	cd/m ²	
	Contrast Ratio(See 6.3)	CR		640	800	-		
	Response Time (See 6.2)	TR+TF		-	30	40	ms	
	Chromaticity Transmissive (See 6.5)	Red	XR	Center CR ≥ 10	0.554	0.604	0.654	
			YR		0.300	0.350	0.400	
		Green	XG		0.306	0.356	0.406	
			YG		0.546	0.596	0.646	
		Blue	XB		0.095	0.145	0.195	
			YB		0.066	0.116	0.166	
	White	XW	0.272	0.322	0.372			
		YW	0.322	0.372	0.422			
	Viewing Angle (See 6.4)	Horizontal	θ_{x+}	Center CR ≥ 10	70	80	-	Deg.
			θ_{x-}		70	80	-	
Vertical		ϕ_{y+}	70		80	-		
		ϕ_{y-}	70		80	-		
NSTC			$\Theta = 0^\circ$	45	50		%	

6.2. Definition of Response Time

6.2.1. Normally Black Type (Negative)

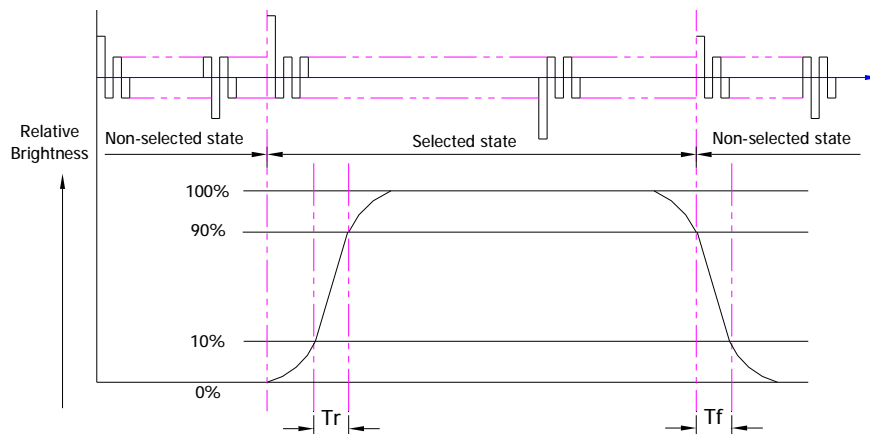

Tr is the time it takes to change from non-selected state with relative luminance 10% to selected state with relative luminance 90%;

Tf is the time it takes to change from selected state with relative luminance 90% to non-selected state with relative luminance 10%

Note: Measuring machine: LCD-5100

6.2.2. Normally White Type (Positive)

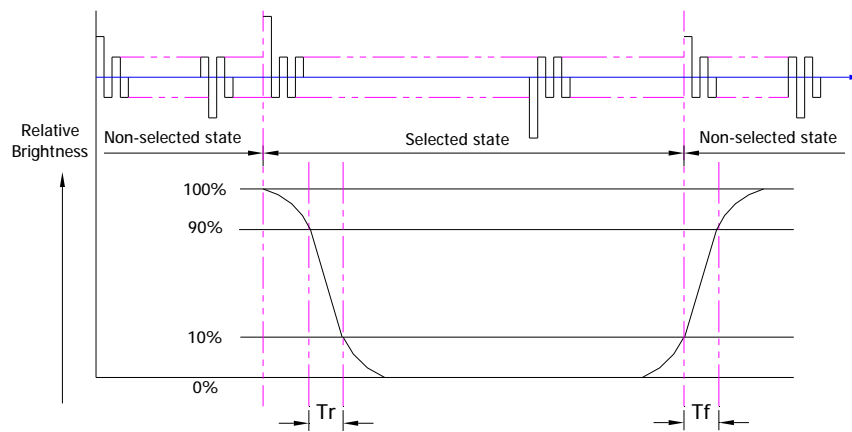

T_r is the time it takes to change from non-selected stage with relative luminance 90% to selected state with relative luminance 10%;

T_f is the time it takes to change from selected state with relative luminance 10% to non-selected state with relative luminance 90%;

Note: Measuring machine: LCD-5100 or EQUI

6.3. Definition of Contrast Ratio

Contrast is measured perpendicular to display surface in reflective and transmissive mode. The measurement condition is:

Measuring Equipment	Eldim or Equivalent
Measuring Point Diameter	3mm//1mm
Measuring Point Location	Active Area centre point
Test Pattern	A: All Pixels white
	B: All Pixel black
Contrast Setting	Maximum

Definitions: CR (Contrast) = Luminance of White Pixel / Luminance of Black Pixel

6.4. Definition of Viewing Angles

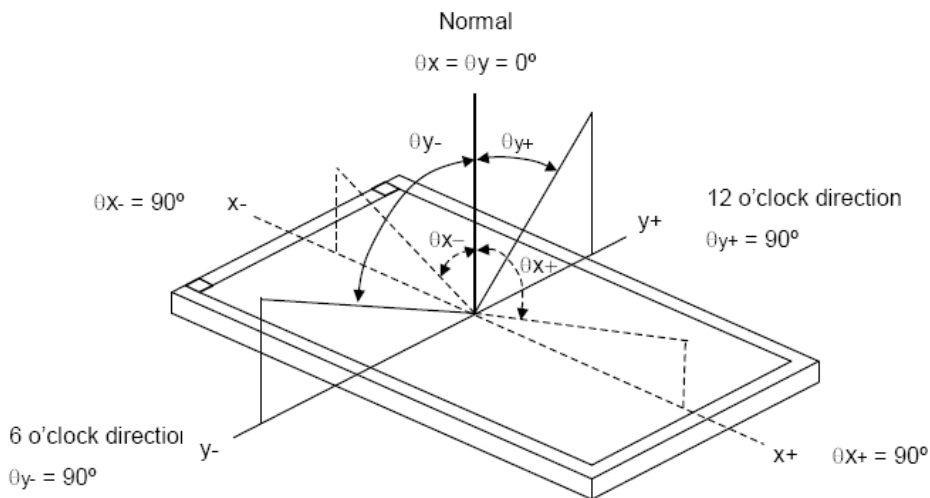

Measuring machine: LCD-5100 or EQUI

6.5. Definition of Color Appearance

R,G,B and W are defined by (x, y) on the IE chromaticity diagram

NTSC=area of RGB triangle/area of NTSC triangleX100%

Measuring picture: Red, Green, Blue and White (Measuring machine: BM-7)

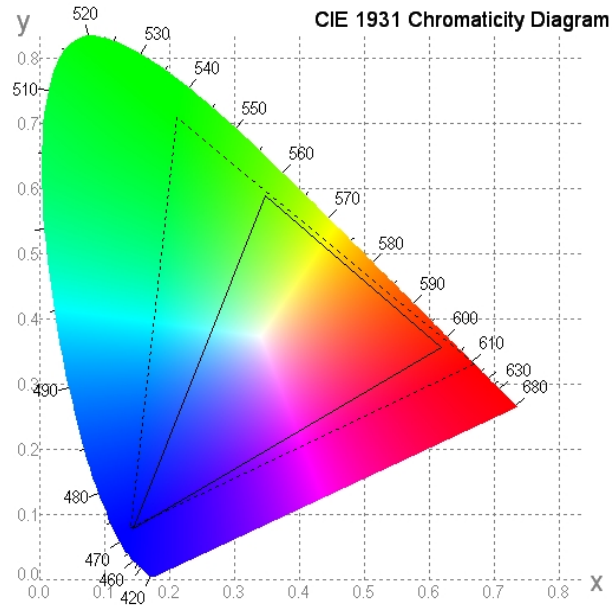

6.6. Definition of Surface Luminance, Uniformity and Transmittance

Using the transmissive mode measurement approach, measure the white screen luminance of the display panel and backlight.

6.6.1. Surface Luminance: $L_v = \text{average} (L_{P1}:L_{P9})$

6.6.2. Uniformity = $\text{Minimal} (L_{P1}:L_{P9}) / \text{Maximal} (L_{P1}:L_{P9}) * 100\%$

6.6.3. Transmittance = $L_v \text{ on LCD} / L_v \text{ on Backlight} * 100\%$

Note: Measuring machine: BM-7

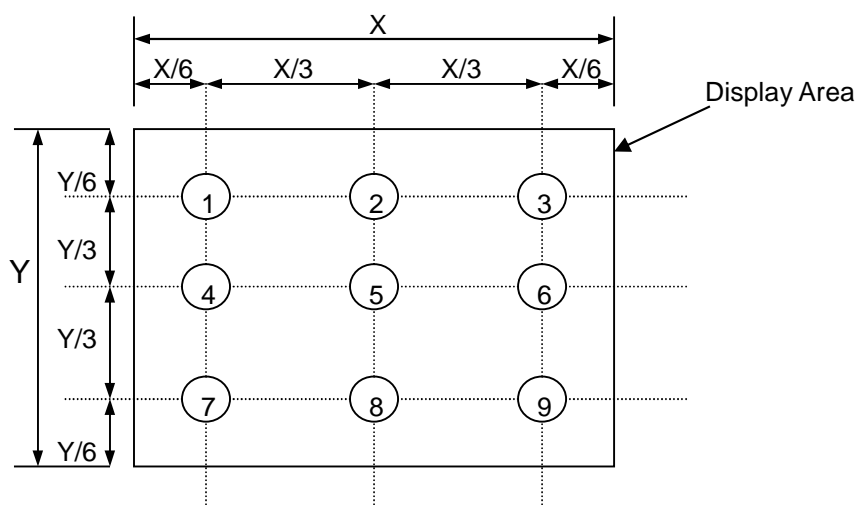

7. Block Diagram and Power Supply

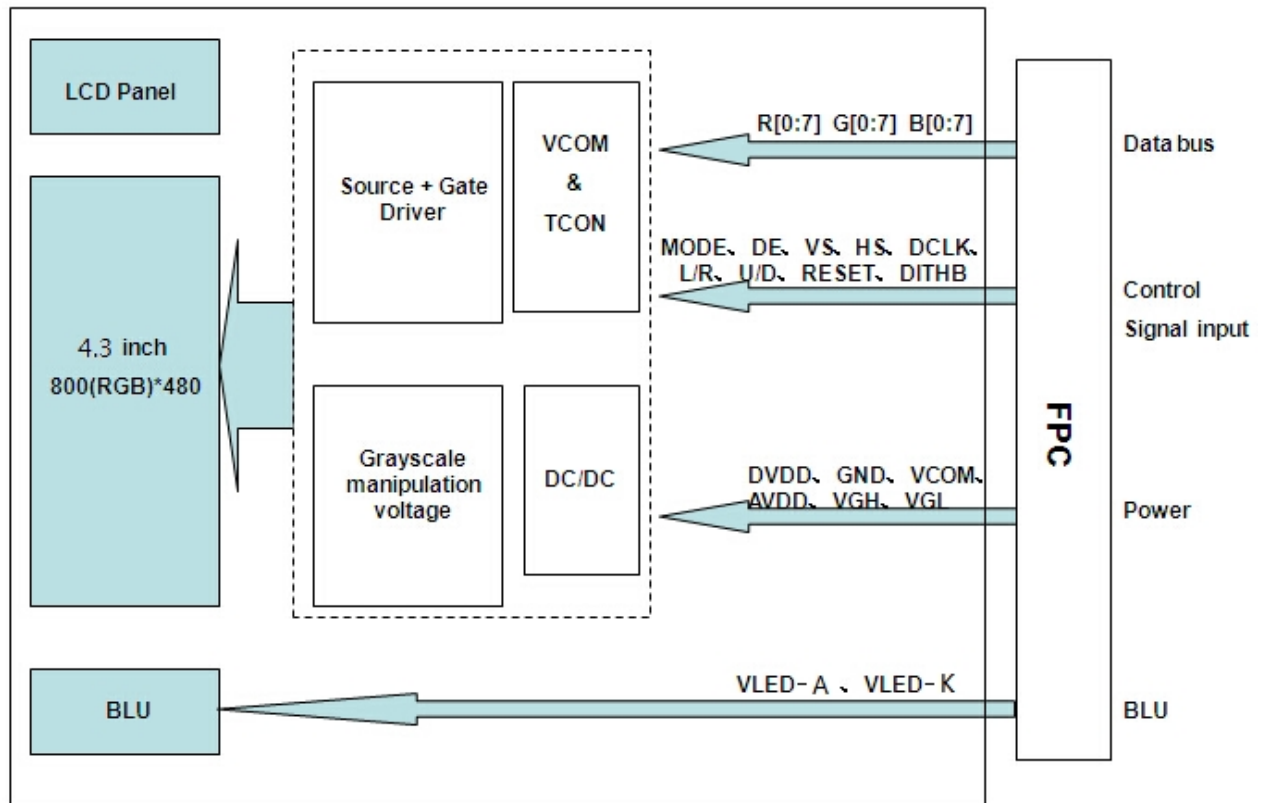

8. Interface Pins Definition

No.	Symbol	Function	Remark
1	VLED-A	LED Anode	
2	VLED-K	LED Cathode	
3	AVDD	Power for Analog Circuit.	
4	GND	Ground.	
5	DVDD	Power for Digital Circuit.	
6	RESET	Global reset pin. Active low to enter Reset State	
7	U/D	Up / Down selection.	Note 4
8	L/R	Left / right selection.	Note 3
9	DITHB	Dithering function enable control. Normally pull high. DITHB="1": Disable internal dithering function. (Default) DITHB="0": Enable internal dithering function.	
10	MODE	DE/SYNC mode select.	Note 1
11	R0	Red data(LSB)	Note 2
12	R1	Red data	Note 2
13	R2	Red data	
14	R3	Red data	
15	R4	Red data	
16	R5	Red data	
17	R6	Red data	
18	R7	Red data(MSB)	
19	G0	Green data(LSB)	Note 2
20	G1	Green data	Note 2
21	G2	Green data	
22	G3	Green data	
23	G4	Green data	
24	G5	Green data	
25	G6	Green data	
26	G7	Green data(MSB)	
27	B0	Blue data(LSB)	Note 2
28	B1	Blue data	Note 2
29	B2	Blue data	
30	B3	Blue data	
31	B4	Blue data	
32	B5	Blue data	
33	B6	Blue data	
34	B7	Blue data(MSB)	
35	GND	Ground.	
36	DCLK	Clock for input data. Data latched at rising/falling edge of this signal.	
37	DE	Data Input Enable.	

38	HS	Horizontal Sync Input.	
39	VS	Vertical Sync Input.	
40	NC	No connection.	
41	YU	No connection.	
42	XL	No connection.	
43	YD	No connection.	
44	XR	No connection.	
45	NC	No connection.	
46	VGH	Gate ON Voltage.	
47	VGL	Gate OFF Voltage.	
48	VCOM	Common voltage.	
49	GND	Ground	
50	NC	No connection.	

Note 1: DE/SYNC mode select. Normally pull high.

When MODE="1", DE mode,

When MODE="0", SYNC mode,

Note 2: When input 18 bits RGB data, the two low bits of R,G and B data must be grounded.

Note 3: Source Right or Left sequence control. Normally pulled high.

L/R="0": Shift left: last data=S1 _ S2 _ S3..... _S1200=first data.

L/R="1": Shift right: first data=S1_S2_S3....._S1200=last data.

Note 4: Gate up or down scan control. Normally pulled low.

U/D="0": STV2 output vertical start pulse and UD pin output logical "0" to gate driver. (Default)

U/D="1": STV1 output vertical start pulse and UD pin output logical "1" to gate driver.

9. AC Characteristics

9.1 AC Electrical Characteristics

Parameter	Symbol	Spec.			Unit
		Min.	Typ.	Max.	
HS setup time	T_{hst}	8	-	-	ns
HS hold time	T_{hhd}	8	-	-	ns
VS setup time	T_{vst}	8	-	-	ns
VS hold time	T_{vhd}	8	-	-	ns
Data setup time	T_{dsu}	8	-	-	ns
Data hold time	T_{dhd}	8	-	-	ns
DE setup time	T_{esu}	8	-	-	ns
DE hold time	T_{ehd}	8	-	-	ns
VDD Power On Slew rate	T_{POR}	-	-	20	ms
RSTB pulse width	T_{Rst}	10	-	-	us
CLKIN cycle time	T_{cph}	20	-	-	ns
CLKIN pulse duty	T_{cwh}	40	50	60	%
Output stable time	T_{sst}	-	-	6	us

9.2 Data Input Format

Horizontal timing

Parameter	Symbol	Spec.			Unit
		Min.	Typ.	Max.	
Horizontal Display Area	thd	800			DCLK
DCLK frequency	fclk	-	30	50	MHz
One Horizontal Line	th	889	928	1143	DCLK
HS pulse width	thpw	1	48	255	DCLK
HS Back Porch (Blanking)	thb	88			DCLK
HS Front Porch	thfp	1	40	255	DCLK
DE mode Blanking	th-thd	85	128	512	DCLK

Vertical timing

Parameter	Symbol	Spec.			Unit
		Min.	Typ.	Max.	
Vertical Display Area	tvd	480			T_H
VS period time	tv	513	525	767	T_H
VS pulse width	tvpw	3	3	255	T_H
VS Back Porch (Blanking)	tvb	32			T_H
VS Front Porch	tvfp	1	13	255	T_H
DE mode Blanking	tv-tvd	4	45	255	T_H

9.3 Horizontal Input Timing Diagram

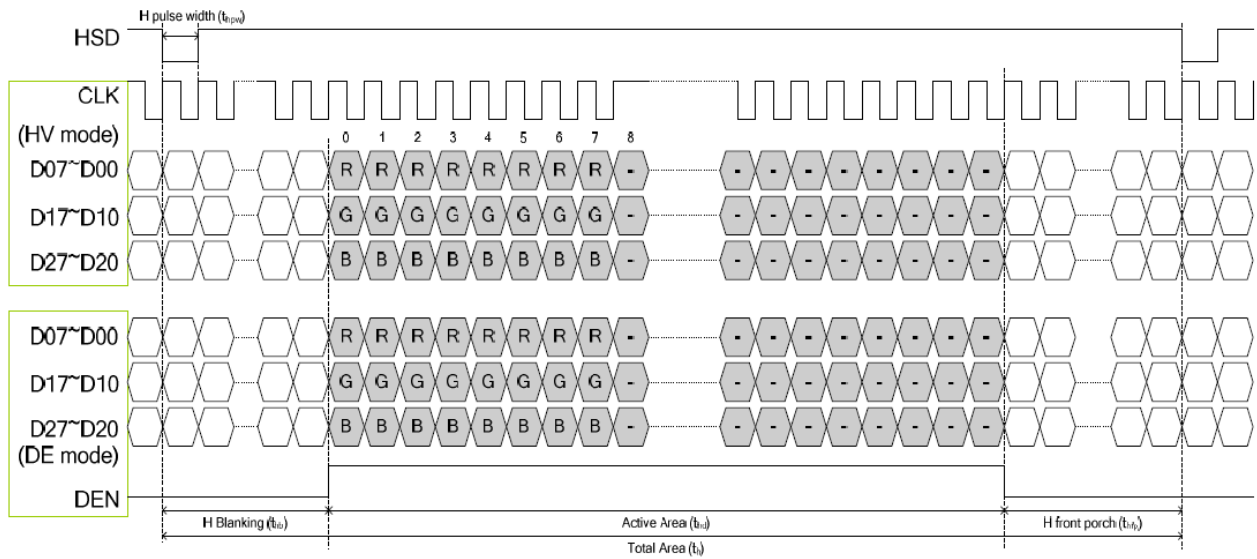

9.4 Vertical Input Timing Diagram

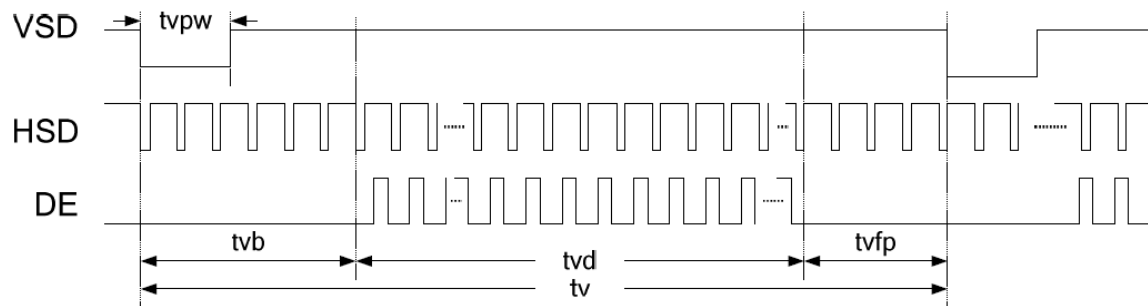

10. Power on/off Sequence

To prevent the device damage from latch up, the power on/off sequence shown below must be followed.

Power ON: VDD, VSS _ VDDA, VSSA

Power OFF: VDDA, VSSA _ VDD, VSS

10.1 Power On/Off Control

HX8264-D has a power on/off sequence control function. In order to prevent IC from power on reset fail, the rising time (TPOR) of the digital power supply VDD should be maintained within the given specifications.

Please refer to “AC Characteristics” for more detail on timing.

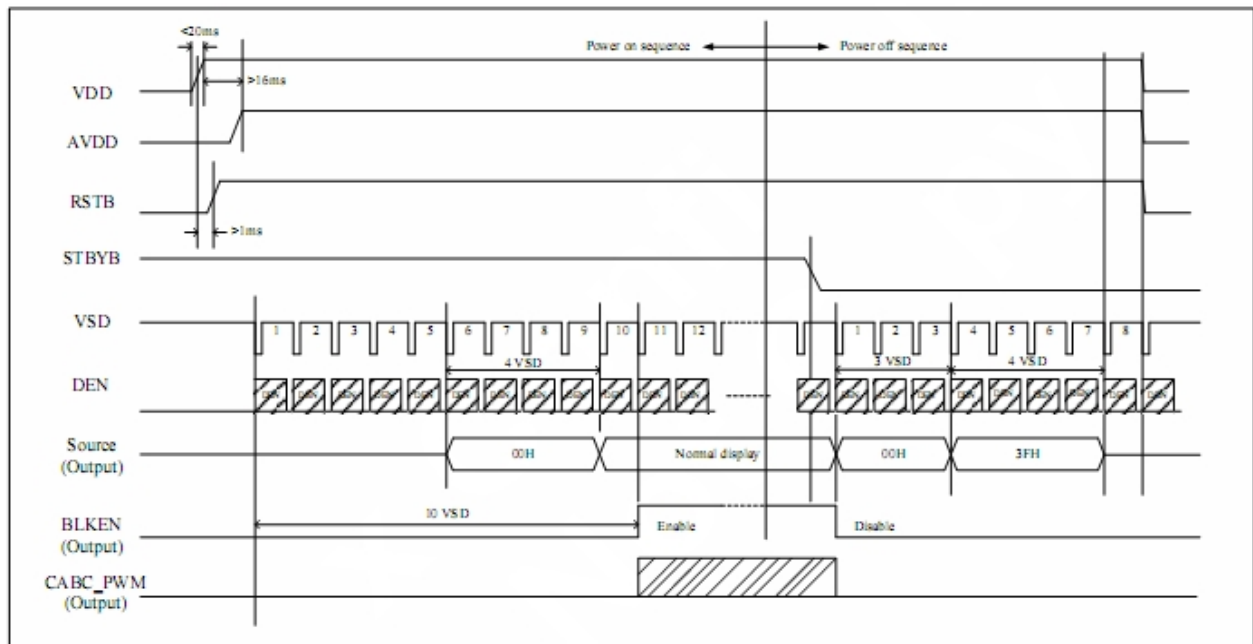

10.2 Enter and Exit Standby Mode Sequence

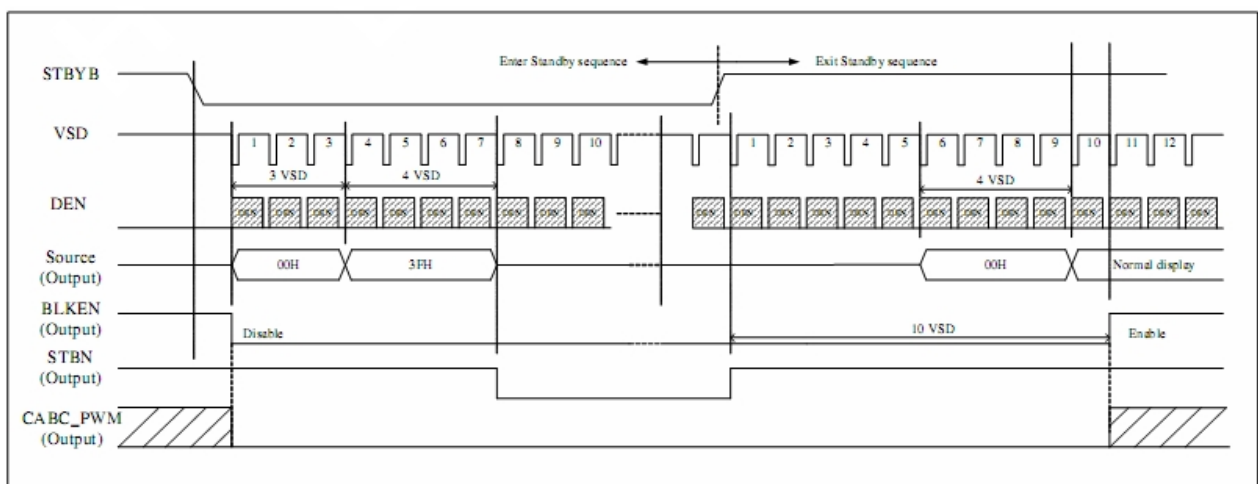

11. Quality Assurance

11.1.Purpose

This standard for Quality Assurance assures the quality of LCD module products supplied to customer.

11.2.Standard for Quality Test

11.2.1. Sampling Plan:

GB2828.1-2012

Single sampling, general inspection level II

11.2.2. Sampling Criteria:

Visual inspection: AQL 1.5%

Electrical functional: AQL 0.65%.

11.2.3. Reliability Test:

Detailed requirement refer to Reliability Test Specification.

11.3.Nonconforming Analysis & Disposition

11.3.1. Nonconforming analysis:

11.3.1.1. Customer should provide overall information of non-conforming sample for their complaints.

11.3.1.2. After receipt of detailed information from customer, the analysis of nonconforming parts usually should be finished in one week.

11.3.1.3. If cannot finish the analysis on time, customer will be notified with the progress status.

11.3.2. Disposition of nonconforming:

11.3.2.1. Non-conforming product over PPM level will be replaced.

11.3.2.2. The cause of non-conformance will be analyzed. Corrective action will be discussed and implemented.

11.4.Agreement Items

Shall negotiate with customer if the following situation occurs:

11.4.1. There is any discrepancy in standard of quality assurance.

11.4.2. Additional requirement to be added in product specification.

11.4.3. Any other special problem.

11.5. Standard of the Product Visual Inspection

11.5.1. Appearance inspection:

11.5.1.1. The inspection must be under illumination about 1000 – 1500 lx, and the distance of view must be at 30cm ± 2cm.

11.5.1.2. The viewing angle should be 45° from the vertical line without reflection light or follows customer's viewing angle specifications.

11.5.1.3. Definition of area: A Zone: Active Area, B Zone: Viewing Area,

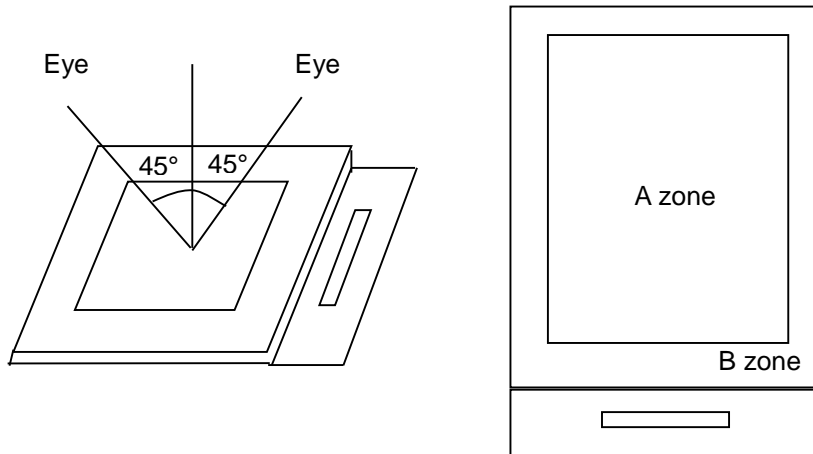

11.5.2. Basic principle:

11.5.2.1. A set of sample to indicate the limit of acceptable quality level must be discussed by both us and customer when there is any dispute happened.

11.5.2.2. New item must be added on time when it is necessary.

11.6. Inspection Specification

No.	Item	Criteria (Unit: mm)																			
01	Black / White spot Foreign material (Round type) Pinholes Stain Particles inside cell. (Minor defect)	<p>$\phi = (a + b) / 2$ Distance between 2 defects should more than 5mm apart.</p>	<table border="1"> <thead> <tr> <th>Size</th> <th>Area</th> <th>Acc. Qty</th> </tr> </thead> <tbody> <tr> <td>$\phi \leq 0.10$</td> <td></td> <td>Ignore</td> </tr> <tr> <td>$0.10 < \phi \leq 0.15$</td> <td></td> <td>2</td> </tr> <tr> <td>$0.15 < \phi \leq 0.25$</td> <td></td> <td>1</td> </tr> <tr> <td>$0.25 < \phi$</td> <td></td> <td>0</td> </tr> <tr> <td>Total</td> <td></td> <td>2 no include $\phi \leq 0.10$</td> </tr> </tbody> </table>	Size	Area	Acc. Qty	$\phi \leq 0.10$		Ignore	$0.10 < \phi \leq 0.15$		2	$0.15 < \phi \leq 0.25$		1	$0.25 < \phi$		0	Total		2 no include $\phi \leq 0.10$
			Size	Area	Acc. Qty																
$\phi \leq 0.10$		Ignore																			
$0.10 < \phi \leq 0.15$		2																			
$0.15 < \phi \leq 0.25$		1																			
$0.25 < \phi$		0																			
Total		2 no include $\phi \leq 0.10$																			

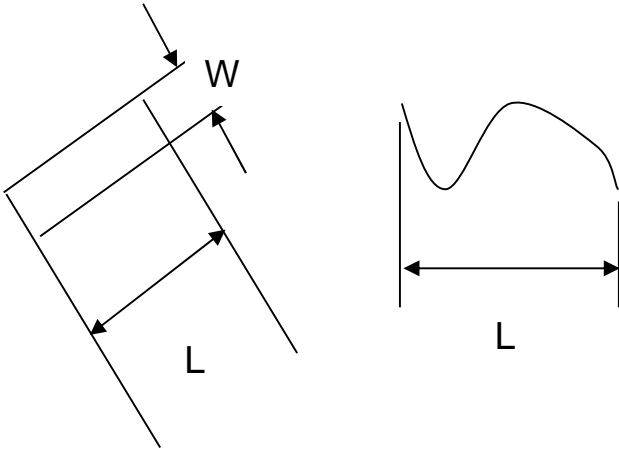
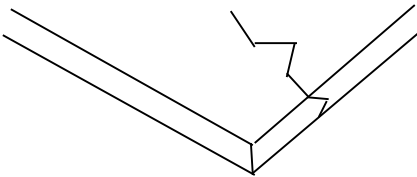
02	Electrical Defect (Minor defect)	<table border="1"> <thead> <tr> <th></th> <th>Display Area</th> <th>Total</th> <th rowspan="3">Note1</th> </tr> </thead> <tbody> <tr> <td>Bright dot</td> <td>0</td> <td>0</td> </tr> <tr> <td>Dark dot</td> <td>$N \leq 2$</td> <td>$N \leq 2$</td> </tr> <tr> <td>Total dot</td> <td>$N \leq 2$</td> <td>$N \leq 2$</td> <td></td> </tr> <tr> <td>Mura</td> <td colspan="2">Not visible through 5% ND filters.</td> <td>Note 2</td> </tr> </tbody> </table>		Display Area	Total	Note1	Bright dot	0	0	Dark dot	$N \leq 2$	$N \leq 2$	Total dot	$N \leq 2$	$N \leq 2$		Mura	Not visible through 5% ND filters.		Note 2
			Display Area	Total	Note1															
Bright dot	0	0																		
Dark dot	$N \leq 2$	$N \leq 2$																		
Total dot	$N \leq 2$	$N \leq 2$																		
Mura	Not visible through 5% ND filters.		Note 2																	
Remark: 1. Bright dot caused by scratch and foreign object accords to item 1.																				
03	Black and White line Scratch Foreign material (Line type) (Minor defect)																			
		<table border="1"> <thead> <tr> <th>Length</th> <th>Width</th> <th>Acc. Qty</th> </tr> </thead> <tbody> <tr> <td>/</td> <td>$W \leq 0.1$</td> <td>Ignore</td> </tr> <tr> <td>$L \leq 2.5$</td> <td>$0.1 < W \leq 0.2$</td> <td>3</td> </tr> <tr> <td>$L > 2.5$</td> <td>$0.2 < W$</td> <td>0</td> </tr> <tr> <td colspan="2">Total</td> <td>3</td> </tr> </tbody> </table>	Length	Width	Acc. Qty	/	$W \leq 0.1$	Ignore	$L \leq 2.5$	$0.1 < W \leq 0.2$	3	$L > 2.5$	$0.2 < W$	0	Total		3			
Length	Width	Acc. Qty																		
/	$W \leq 0.1$	Ignore																		
$L \leq 2.5$	$0.1 < W \leq 0.2$	3																		
$L > 2.5$	$0.2 < W$	0																		
Total		3																		
Distance between 2 defects should more than 3mm apart. Scratches not viewable through the back of the display are acceptable.																				
04	Glass Crack (Minor defect)																			
Crack is potential to enlarge, any type is not allowed.																				

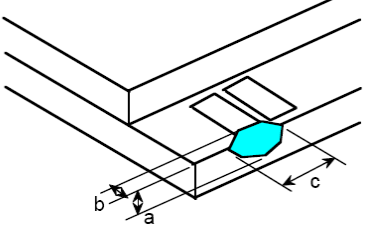
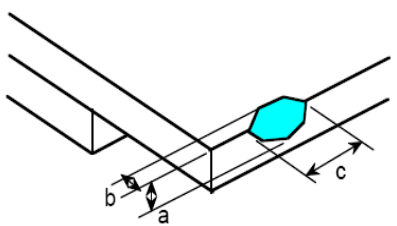
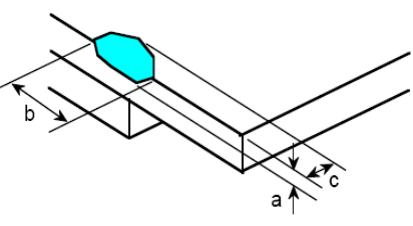
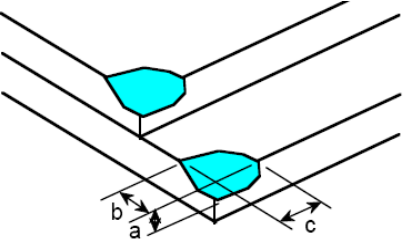
<p>05</p>	<p>Glass Chipping Pad Area: (Minor defect)</p> 	<table border="1"> <thead> <tr> <th>Length and Width</th> <th>Acc. Qty</th> </tr> </thead> <tbody> <tr> <td>$c > 3.0, b < 1.0$</td> <td>1</td> </tr> <tr> <td>$c < 3.0, b < 1.0$</td> <td>3</td> </tr> <tr> <td colspan="2">$a < \text{Glass Thickness}$</td> </tr> </tbody> </table>	Length and Width	Acc. Qty	$c > 3.0, b < 1.0$	1	$c < 3.0, b < 1.0$	3	$a < \text{Glass Thickness}$			
Length and Width	Acc. Qty											
$c > 3.0, b < 1.0$	1											
$c < 3.0, b < 1.0$	3											
$a < \text{Glass Thickness}$												
<p>06</p>	<p>Glass Chipping Rear of Pad Area: (Minor defect)</p> 	<table border="1"> <thead> <tr> <th>Length and Width</th> <th>Acc. Qty</th> </tr> </thead> <tbody> <tr> <td>$c > 3.0, b < 1.0$</td> <td>1</td> </tr> <tr> <td>$c < 3.0, b < 1.0$</td> <td>2</td> </tr> <tr> <td>$c < 3.0, b < 0.5$</td> <td>4</td> </tr> <tr> <td colspan="2">$a < \text{Glass Thickness}$</td> </tr> </tbody> </table>	Length and Width	Acc. Qty	$c > 3.0, b < 1.0$	1	$c < 3.0, b < 1.0$	2	$c < 3.0, b < 0.5$	4	$a < \text{Glass Thickness}$	
Length and Width	Acc. Qty											
$c > 3.0, b < 1.0$	1											
$c < 3.0, b < 1.0$	2											
$c < 3.0, b < 0.5$	4											
$a < \text{Glass Thickness}$												
<p>07</p>	<p>Glass Chipping Except Pad Area: (Minor defect)</p> 	<table border="1"> <thead> <tr> <th>Length and Width</th> <th>Acc. Qty</th> </tr> </thead> <tbody> <tr> <td>$c > 3.0, b < 1.0$</td> <td>1</td> </tr> <tr> <td>$c < 3.0, b < 1.0$</td> <td>2</td> </tr> <tr> <td>$c < 3.0, b < 0.5$</td> <td>4</td> </tr> <tr> <td colspan="2">$a < \text{Glass Thickness}$</td> </tr> </tbody> </table>	Length and Width	Acc. Qty	$c > 3.0, b < 1.0$	1	$c < 3.0, b < 1.0$	2	$c < 3.0, b < 0.5$	4	$a < \text{Glass Thickness}$	
Length and Width	Acc. Qty											
$c > 3.0, b < 1.0$	1											
$c < 3.0, b < 1.0$	2											
$c < 3.0, b < 0.5$	4											
$a < \text{Glass Thickness}$												
<p>08</p>	<p>Glass Corner Chipping: (Minor defect)</p> 	<table border="1"> <thead> <tr> <th>Length and Width</th> <th>Acc. Qty</th> </tr> </thead> <tbody> <tr> <td>$c < 3.0, b < 3.0$</td> <td>Ignore</td> </tr> <tr> <td colspan="2">$a < \text{Glass Thickness}$</td> </tr> </tbody> </table>	Length and Width	Acc. Qty	$c < 3.0, b < 3.0$	Ignore	$a < \text{Glass Thickness}$					
Length and Width	Acc. Qty											
$c < 3.0, b < 3.0$	Ignore											
$a < \text{Glass Thickness}$												

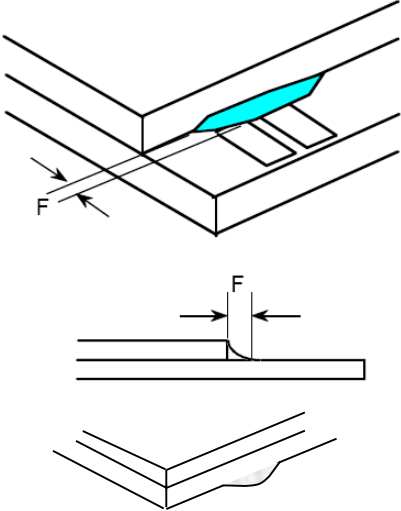
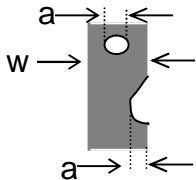
<p>09</p>	<p>Glass Burr: (Minor defect)</p> 	<table border="1" data-bbox="882 264 1355 351"> <thead> <tr> <th>Length</th> <th>Acc. Qty</th> </tr> </thead> <tbody> <tr> <td>$F < 1.0$</td> <td>Ignore</td> </tr> </tbody> </table> <p>Glass burr don't affect assemble and module dimension.</p>	Length	Acc. Qty	$F < 1.0$	Ignore				
Length	Acc. Qty									
$F < 1.0$	Ignore									
<p>10</p>	<p>FPC Defect: (Minor defect)</p> 	<p>10.1 Dent, pinhole width $a < w/3$. (w: circuitry width.)</p> <p>10.2 Open circuit is unacceptable.</p> <p>10.3 No oxidation, contamination and distortion.</p>								
<p>11</p>	<p>Bubble on Polarizer (Minor defect)</p>	<table border="1" data-bbox="758 1272 1227 1444"> <thead> <tr> <th>Diameter</th> <th>Acc. Qty</th> </tr> </thead> <tbody> <tr> <td>$\varphi \leq 0.30$</td> <td>Ignore</td> </tr> <tr> <td>$0.30 < \varphi \leq 0.50$</td> <td>$N \leq 2$</td> </tr> <tr> <td>$0.50 < \varphi$</td> <td>$N = 0$</td> </tr> </tbody> </table>	Diameter	Acc. Qty	$\varphi \leq 0.30$	Ignore	$0.30 < \varphi \leq 0.50$	$N \leq 2$	$0.50 < \varphi$	$N = 0$
Diameter	Acc. Qty									
$\varphi \leq 0.30$	Ignore									
$0.30 < \varphi \leq 0.50$	$N \leq 2$									
$0.50 < \varphi$	$N = 0$									
<p>12</p>	<p>Dent on Polarizer (Minor defect)</p>	<table border="1" data-bbox="758 1514 1227 1686"> <thead> <tr> <th>Diameter</th> <th>Acc. Qty</th> </tr> </thead> <tbody> <tr> <td>$\varphi \leq 0.25$</td> <td>Ignore</td> </tr> <tr> <td>$0.25 < \varphi \leq 0.50$</td> <td>$N \leq 4$</td> </tr> <tr> <td>$0.50 < \varphi$</td> <td>None</td> </tr> </tbody> </table>	Diameter	Acc. Qty	$\varphi \leq 0.25$	Ignore	$0.25 < \varphi \leq 0.50$	$N \leq 4$	$0.50 < \varphi$	None
Diameter	Acc. Qty									
$\varphi \leq 0.25$	Ignore									
$0.25 < \varphi \leq 0.50$	$N \leq 4$									
$0.50 < \varphi$	None									
<p>13</p>	<p>Bezel</p>	<p>13.1 No rust, distortion on the Bezel.</p> <p>13.2 No visible fingerprints, stains or other contamination.</p>								

14	Touch Panel	<p>D: Diameter W: width L: length</p> <p>14.1 Spot: $D < 0.25$ is acceptable $0.25 \leq D \leq 0.4$</p> <p>2dots are acceptable and the distance between defects should more than 10 mm.</p> <p>$D > 0.4$ is unacceptable</p> <p>14.2 Dent: $D > 0.40$ is unacceptable</p> <p>14.3 Scratch: $W \leq 0.03$, $L \leq 10$ is acceptable, $0.03 < W \leq 0.10$, $L \leq 10$ is acceptable</p> <p>Distance between 2 defects should more than 10 mm. $W > 0.10$ is unacceptable.</p>
15	PCB	<p>15.1 No distortion or contamination on PCB terminals.</p> <p>15.2 All components on PCB must same as documented on the BOM/component layout.</p> <p>15.3 Follow IPC-A-600F.</p>
16	Soldering	Follow IPC-A-610C standard
17	Electrical Defect (Major defect)	<p>The below defects must be rejected.</p> <p>17.1 Missing vertical / horizontal segment,</p> <p>17.2 Abnormal Display.</p> <p>17.3 No function or no display.</p> <p>17.4 Current exceeds product specifications.</p> <p>17.5 LCD viewing angle defect.</p> <p>17.6 No Backlight.</p> <p>17.7 Dark Backlight.</p> <p>17.8 Touch Panel no function.</p>

Remark: LCD Panel Broken shall be rejected. Defect out of LCD viewing area is acceptable.

11.7. Classification of Defects

11.7.1. Visual defects (Except no / wrong label) are treated as minor defect and electrical defect is major.

11.7.2. Two minor defects are equal to one major in lot sampling inspection.

11.8. Identification/marketing criteria

Any unit with illegible / wrong /double or no marking/ label shall be rejected.

11.9.Packaging

- 11.9.1. There should be no damage of the outside carton box, each packaging box should have one identical label.
- 11.9.2. Modules inside package box should have compliant mark.
- 11.9.3. All direct package materials shall offer ESD protection

Note1: Bright dot is defined as the defective area of the dot is larger than 50% of one sub-pixel area.

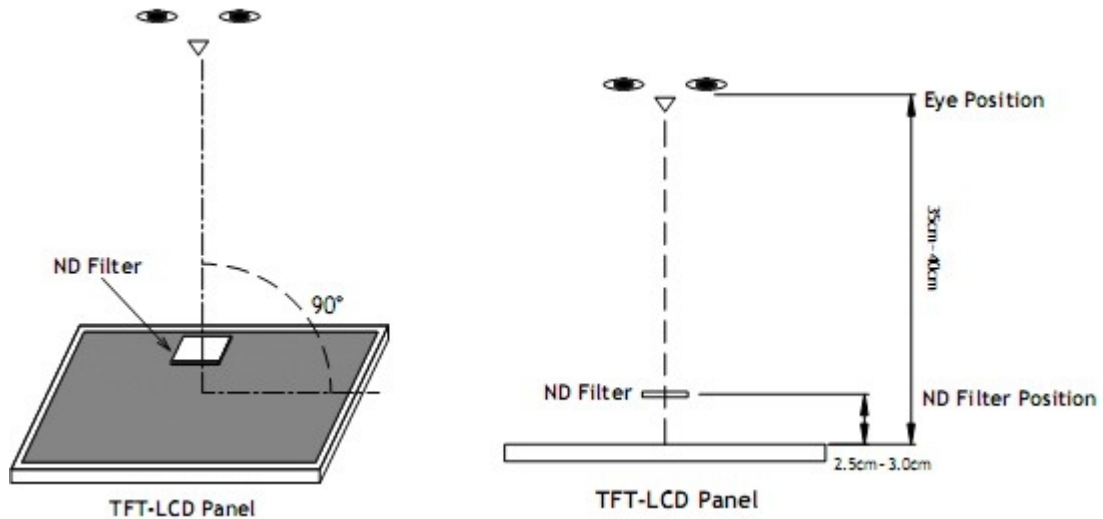

Bright dot: The bright dot size defect at black display pattern. It can be recognized by 2% transparency of filter when the distance between eyes and panel is 350mm± 50mm.

Dark dot: Cyan, Magenta or Yellow dot size defect at white display pattern. It can be recognized by 5% transparency of filter when the distance between eyes and panel is 350mm± 50mm.

Note2: Mura on display which appears darker / brighter against background brightness on parts of display area.

12. Reliability Specification

No	Item	Condition	Quantity	Criteria
1	High Temperature Operating	+80°C, 96Hrs	2	GB/T2423.2-2008
2	Low Temperature Operating	-20°C, 96Hrs	2	GB/T2423.1-2008
3	High Humidity	+50°C, 90%RH, 96Hrs	2	GB/T2423.3-2016
4	High Temperature Storage	+85°C, 96Hrs	2	GB/T2423.2-2008
5	Low Temperature Storage	-20°C, 96Hrs	2	GB/T2423.1-2008
6	Thermal Cycling Test	-20°C, 60min~+80°C, 60min, 20 cycles.	2	GB/T2423.22-2012
7	Packing vibration	Frequency range:10Hz~50Hz Acceleration of gravity:5G X, Y, Z 30 min for each direction.	2	GB/T5170.14-2009
8	Electrical Static Discharge	Air: ± 4KV 150pF/330Ω 5 times	2	GB/T17626.2-2018
		Contact: ± 2KV 150pF/330Ω 5 times		
9	Drop Test (Packaged)	Height:80 cm,1 corner, 3 edges, 6 surfaces.	2	GB/T2423.8-1995

Note1. No deflection cosmetic and operational function allowable.

Note2. Total current Consumption should be below double of initial value

13. Precautions and Warranty

13.1. Safety

- 13.1.1. The liquid crystal in the LCD is poisonous. Do not put it in your mouth. If the liquid crystal touches your skin or clothes, wash it off immediately using soap and water.
- 13.1.2. Since the liquid crystal cells are made of glass, do not apply strong impact on them. Handle with care.

13.2. Handling

- 13.2.1. Reverse and use within ratings in order to keep performance and prevent damage.
- 13.2.2. Do not wipe the polarizer with dry cloth, as it might cause scratch. If the surface of the LCD needs to be cleaned, wipe it swiftly with cotton or other soft cloth soaked with petroleum IPA, do not use other chemicals.

13.3. Storage

- 13.3.1. Do not store the LCD module beyond the specified temperature ranges.
- 13.3.2. Strong light exposure causes degradation of polarizer and color filter

13.4. Metal Pin (Apply to Products with Metal Pins)

- 13.4.1. Pins of LCD and Backlight
 - 13.4.1.1. Solder tip can touch and press on the tip of Pin LEAD during the soldering
 - 13.4.1.2. Recommended Soldering Conditions
 - Solder Type: Sn96.3~94-Ag3.3~4.3-Cu0.4~1.1
 - Maximum Solder Temperature: 370°C
 - Maximum Solder Time: 3s at the maximum temperature
 - Recommended Soldering Temp: 350±20°C
 - Typical Soldering Time: ≤3s

13.4.1.3. Solder Wetting

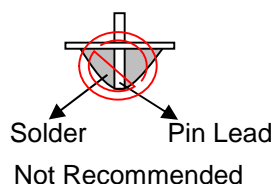
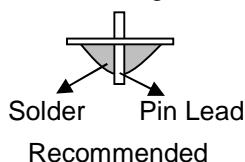

- 13.4.2. Pins of EL
 - 13.4.2.1. Solder tip can touch and press on the tip of EL leads during soldering.
 - 13.4.2.2. No Solder Paste on the soldering pad on the motherboard is recommended.
 - 13.4.2.3. Recommended Soldering Conditions
 - Solder type: Nippon Alimit Leadfree SR-34, size 0.5mm
 - Recommended Solder Temperature: 270~290°C
 - Typical Soldering Time: ≤2s
 - Minimum solder distance from EL lamp (body):2.0mm
 - 13.4.2.4. No horizontal press on the EL leads during soldering.
 - 13.4.2.5. 180° bend EL leads three times is not allowed.

13.4.2.6. Solder Wetting

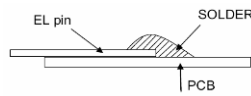

Recommended

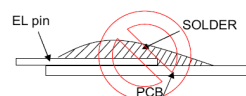

Not Recommended

13.4.2.7. The type of the solder iron:

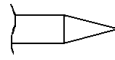

Recommended

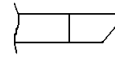

Not Recommended

13.4.2.8. Solder Pad

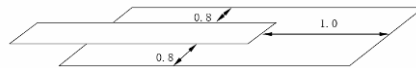

13.5. Operation

- 13.5.1. Do not drive LCD with DC voltage
- 13.5.2. Response time will increase below lower temperature
- 13.5.3. Display may change color with different temperature
- 13.5.4. Mechanical disturbance during operation, such as pressing on the display area, may cause the segments to appear “fractured”.
- 13.5.5. Do not connect or disconnect the LCM to or from the system when power is on.
- 13.5.6. Never use the LCM under abnormal condition of high temperature and high humidity.
- 13.5.7. Module has high frequency circuits. Sufficient suppression to the electromagnetic interface shall be done by system manufacturers. Grounding and shielding methods may be important to minimize the interference.
- 13.5.8. Do not display the fixed pattern for long time (we suggest the time not longer than one hour) because it may develop image sticking due to the TFT structure.

13.6. Static Electricity

- 13.6.1. CMOS LSIs are equipped in this unit, so care must be taken to avoid the electro-static charge, by ground human body, etc.
- 13.6.2. The normal static prevention measures should be observed for work clothes and benches.
- 13.6.3. The module should be kept into anti-static bags or other containers resistant to static for storage.

13.7. Limited Warranty

- 13.7.1. Our warranty liability is limited to repair and/or replacement. We will not be responsible for any consequential loss.
- 13.7.2. If possible, we suggest customer to use up all modules in six months. If the module storage time over twelve months, we suggest that recheck it before the module be used.
- 13.7.3. After the product shipped, any product quality issues must be feedback within three months, otherwise, we will not be responsible for the subsequent or consequential events.

14. Outline Drawing

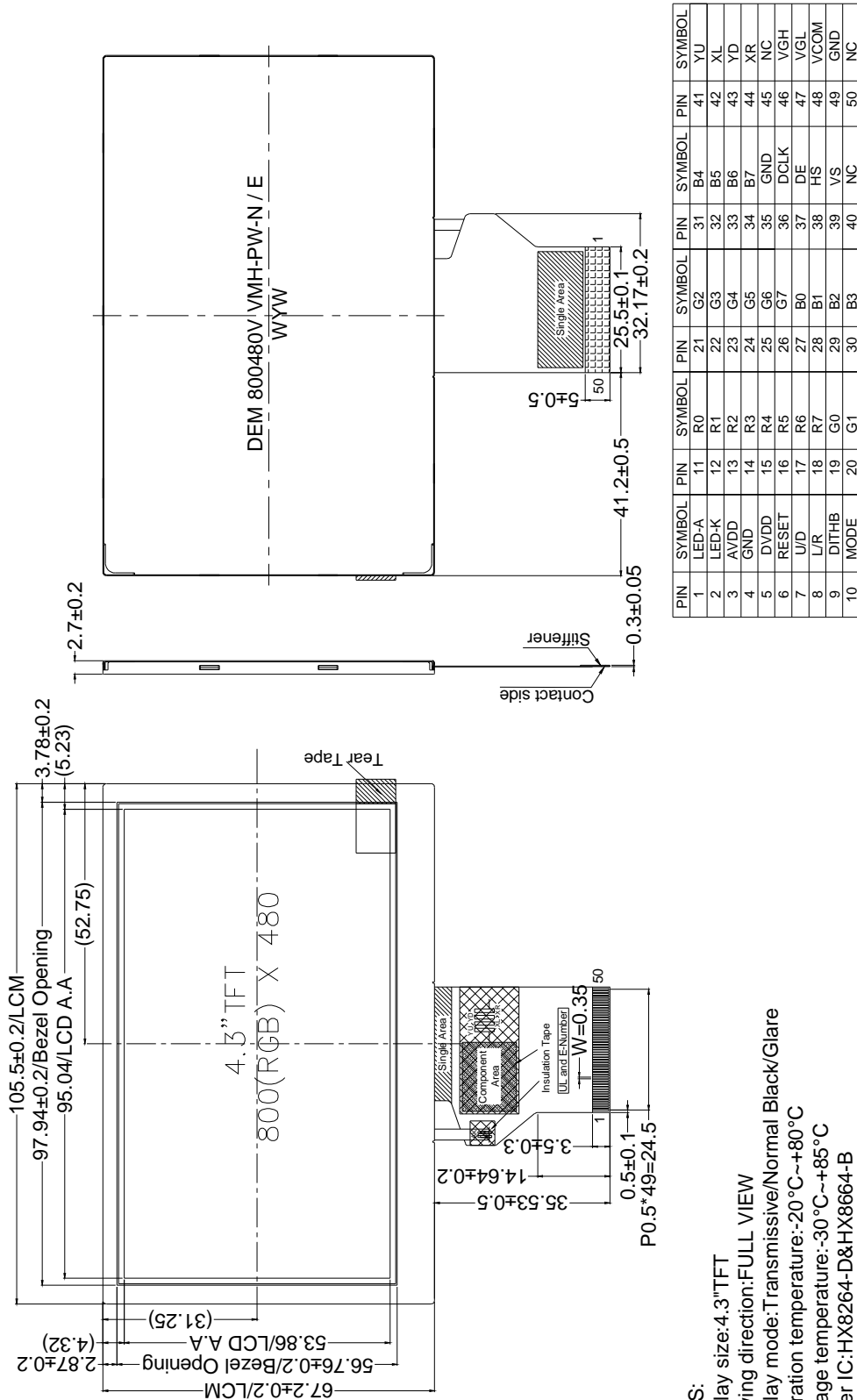

PIN	SYMBOL	PIN	SYMBOL	PIN	SYMBOL	PIN	SYMBOL	PIN	SYMBOL	PIN	SYMBOL
1	LED-A	11	R0	21	G2	31	B4	41	YU		
2	LED-K	12	R1	22	G3	32	B5	42	XL		
3	AVDD	13	R2	23	G4	33	B6	43	YD		
4	GND	14	R3	24	G5	34	B7	44	XR		
5	DVDD	15	R4	25	G6	35	GND	45	NC		
6	RESET	16	R5	26	G7	36	DCLK	46	VGH		
7	U/D	17	R6	27	B0	37	DE	47	VGL		
8	L/R	18	R7	28	B1	38	HS	48	VCOM		
9	DITHB	19	G0	29	B2	39	VS	49	GND		
10	MODE	20	G1	30	B3	40	NC	50	NC		

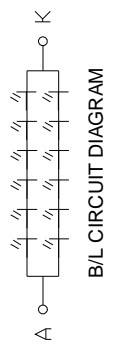

- NOTES:
1. Display size: 4.3" TFT
 2. Viewing direction: FULL VIEW
 3. Display mode: Transmissive/Normal Black/Glare
 4. Operation temperature: -20°C ~ +80°C
 5. Storage temperature: -30°C ~ +85°C
 6. Driver IC: HX8264-D & HX8664-B
 7. Power supply voltage: 3.3V
 8. Backlight: White (12 LED) / 19.2 (TYP) V / 40mA
 9. Brightness: 600 (TYP) cd/m²
LED Time: 30,000 (TYP) / Hrs
 10. ROHS must be complied
- * Unspecification tolerance are ±0.2mm