

**DISPLAY Elektronik GmbH**

# DATA SHEET

**TFT MODULE**

**DEM 320240Q TMH-PW-N**

**3,5" TFT**

*Product Specification*

*Version: 2*

**13.02.2017**

# GENERAL SPECIFICATION

---

MODULE NO. :

## DEM 320240Q TMH-PW-N

CUSTOMER

VERSION NO.	CHANGE DESCRIPTION	DATE
0	ORIGINAL VERSION	20.01.2017
1	CHANGE PRINT NUMBER	08.02.2017
2	CHANGE INTERFACE TYPE TO SPI + 8/9/16-Bit-MCU + 18-Bit-RGB	13.02.2017

PREPARED BY: ZX

DATE: 13.02.2017

APPROVED BY: MH

DATE: 13.02.2017

**CONTENTS**

<b>1. GENERAL SPECIFICATIONS.....</b>	<b>2</b>
<b>2. EXTERNAL DIMENSIONS .....</b>	<b>3</b>
<b>3. BLOCK DIAGRAM .....</b>	<b>4</b>
<b>4. PIN ASSIGNMENT .....</b>	<b>5</b>
<b>5. OPTICAL CHARACTERISTICS .....</b>	<b>7</b>
<b>6. ABSOLUTE MAXIMUM RATINGS.....</b>	<b>10</b>
<b>7. ELECTRICAL CHARACTERISTICS.....</b>	<b>10</b>
<b>8. TIMING CHARACTERISTICS.....</b>	<b>11</b>
<b>9. RELIABILITY TEST .....</b>	<b>14</b>
<b>10. LCD MODULES HANDLING PRECAUTIONS.....</b>	<b>16</b>
<b>11. OTHERS .....</b>	<b>16</b>

**1. GENERAL SPECIFICATIONS**

<b>Item</b>	<b>Contents</b>	<b>Unit</b>
LCD TYPE	TFT / TRANSMISSIVE	-
MODULE SIZE(W*H*T)	76.90 x 63.90 x 3.20	mm
ACTIVE SIZE(W*H)	70.08 x 52.56	mm
PIXEL PITCH(W*H)	0.219 x 0.219	mm
NUMBER OF DOTS	320 x RGB x 240	-
DIVER IC	SSD2119	-
INTERFACE TYPE	SPI+8/9/16Bit-MCU+18-Bit-RGB	-
TOP POLARIZER TYPE	ANTI-GLARE	-
RECOMMEND VIEWING DIRECTION	12	O'CLOCK
GRAY SCALE INVERSION DIRECTION	6	O'CLOCK
COLORS	262K	-
BACKLIGHT TYPE	6-DIES WHITE LED	-
TOUCH PANEL TYPE	No Touch	-

2. EXTERNAL DIMENSIONS

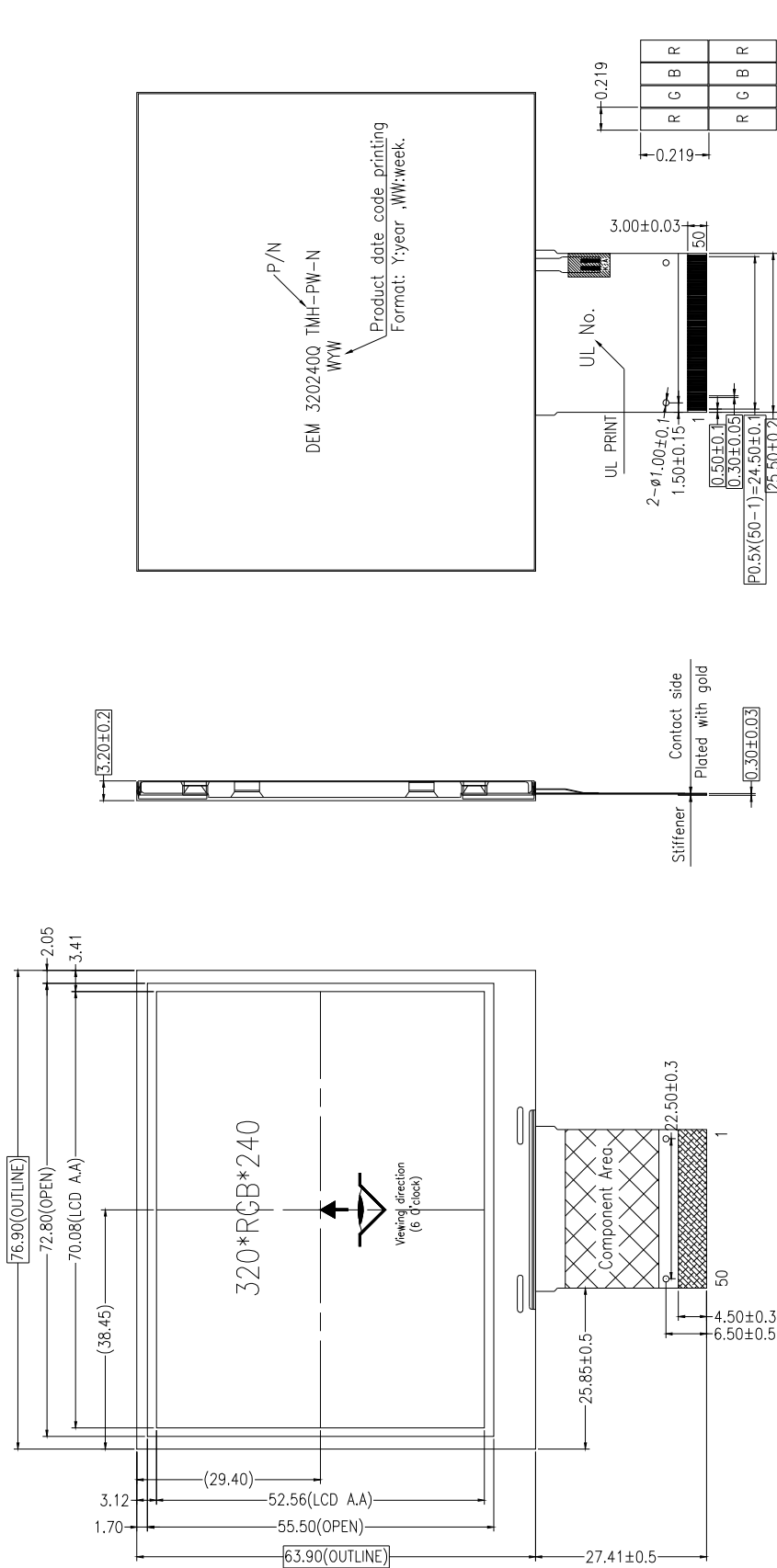

Pixel Detail:  
Scale 50:1

Circuit Diagram

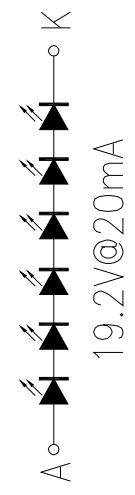

- Remark:
1. Unmarked tolerance is ±0.3
  2. All materials comply with RoHS
  3. □.....critical dimension.

3. BLOCK DIAGRAM

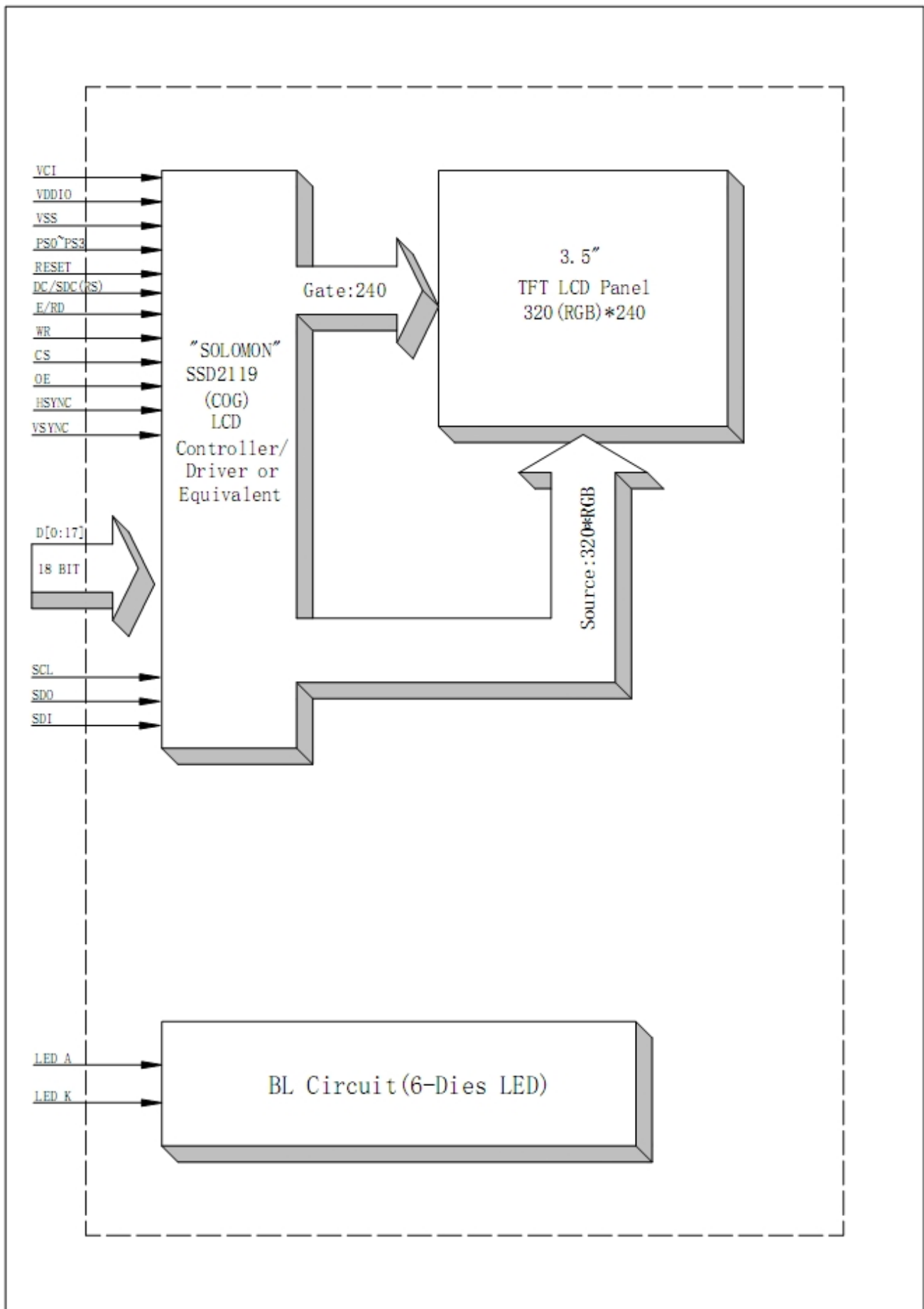

**4. PIN ASSIGNMENT**

<b>Pin No.</b>	<b>Symbol</b>	<b>Description</b>
1-2	VCI	Power supply for analog
3	VSS	Ground
4	VDDIO	Voltage input pin for logic I/O
5	VSS	Ground
6	RESB	System reset pin. -an active low pulse at this pin will reset the IC connect to VDDIO in Normal operation
7	DC/SDC (RS)	A register select signal Low select an index or status register VDDIO in normal operation
8	E/RD	6800-system:E(enable) 8080-system:RD(read strobe signal) Serial mode: not used and should be connected to VDDIO or VSS
9	WR	8080-system:WR(write strobe signal )
10	CS	CS: chip select pin
11	SCL	Serial clock input
12	SDO	Data output pin in serial interface
13	SDI	Data input pin in serial interface
14	WSYNC	RAM write synchronization output -leave it open when not used
15-32	DB17-DB0	Data bus
33	VSS	Ground
34	DOTCLK	Dot-clock signal and oscillator source
35	HSYNC	Line synchronization input
36	VSYNC	Frame/ram write synchronization input
37	OE	Display enable pin from controller
38	VSS	Ground
39	PS0	Refer to table 1
40	PS1	
41	PS2	
42	PS3	
43	VSS	Ground
44-47	NC	Not connection
48	VSS	Ground
49	LEDK	Cathode of LED backlight
50	LEDA	Anode of LED backlight

**TABLE 1:**

<b>PS3</b>	<b>PS2</b>	<b>PS1</b>	<b>PS</b>	<b>INTERFACE MODE</b>
0	0	0	0	16-bit 6800 parallel interface
0	0	0	1	8-bit 6800 parallel interface
0	0	1	0	16-bit 8080 parallel interface
0	0	1	1	8-bit 8080 parallel interface
0	1	0	0	9-bit generic D[17:9](262K color)+3-Wire SPI If 65K colour,D12 shorts to D17 internally
0	1	0	1	16-bit generic (262K color)+3-Wire SPI
0	1	1	0	18-bit generic (262K color)+3-Wire SPI
0	1	1	1	6-bit generic D[17:12](262K color)+3-Wire SPI
1	0	0	0	18-bit 6800 parallel interface
1	0	0	1	9-bit 6800 parallel interface
1	0	1	0	18-bit 8080 parallel interface
1	0	1	1	9-bit 8080 parallel interface
1	1	1	0	3-Wire SPI
1	1	1	1	4-Wire SPI



**5. OPTICAL CHARACTERISTICS**

Item	Symbol	Conditions	Specifications			Unit	Note
			Min	Typ.	Max		
Luminance	L	$I=20\text{mA}$	-	380	-	Cd/m <sup>2</sup>	-
Contrast Ratio	CR	$\theta = 0^\circ$	150	300	-	-	-
Response Time	Ton	25°C	-	35	50	ms	-
	Toff						
CIE Colour Coordinates	RED	XR	Viewing normal angle	-	-	-	-
		YR		-	-	-	-
	GREEN	XG		-	-	-	-
		YG		-	-	-	-
	BLUE	XB		-	-	-	-
		YB		-	-	-	-
	WHITE	XW		0.330	-	-	-
		YW		0.350	-	-	-
Viewing Angle	Hor.	$\theta_{x+}$	$CR \geq 10$	-	60	Degree	-
		$\theta_{x-}$		-	60		-
	Ver.	$\theta_{y+}$		-	50		-
		$\theta_{y-}$		-	60		-
Uniformity	Un	-	-	80	85	%	-

**Note 1: Definition of Viewing Angle  $\theta_x$  and  $\theta_y$ :**

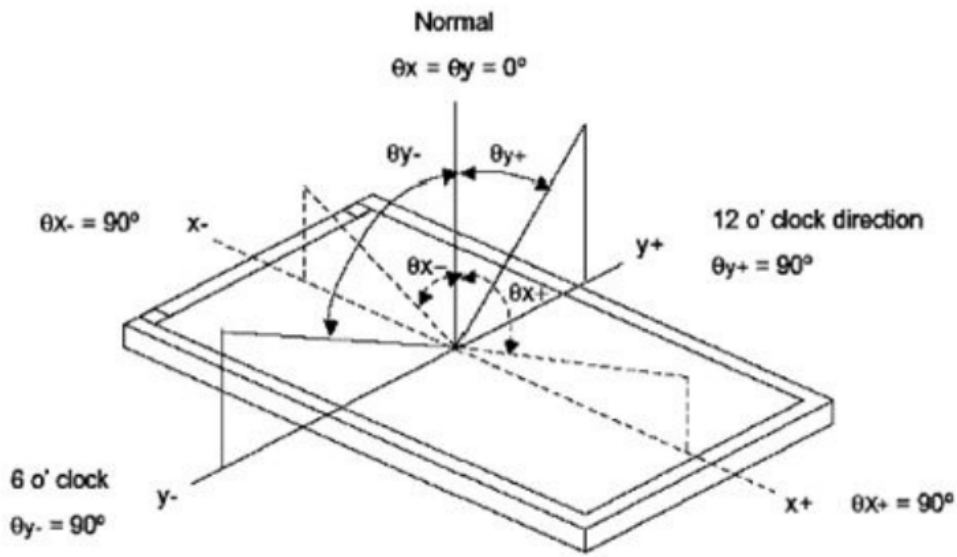

**Note 2: Definition of contrast ratio CR:**

$$CR = \frac{\text{Luminance of white state}}{\text{Luminance of black state}}$$

**Note 3: Definition of Response Time ( $T_r, T_f$ )**

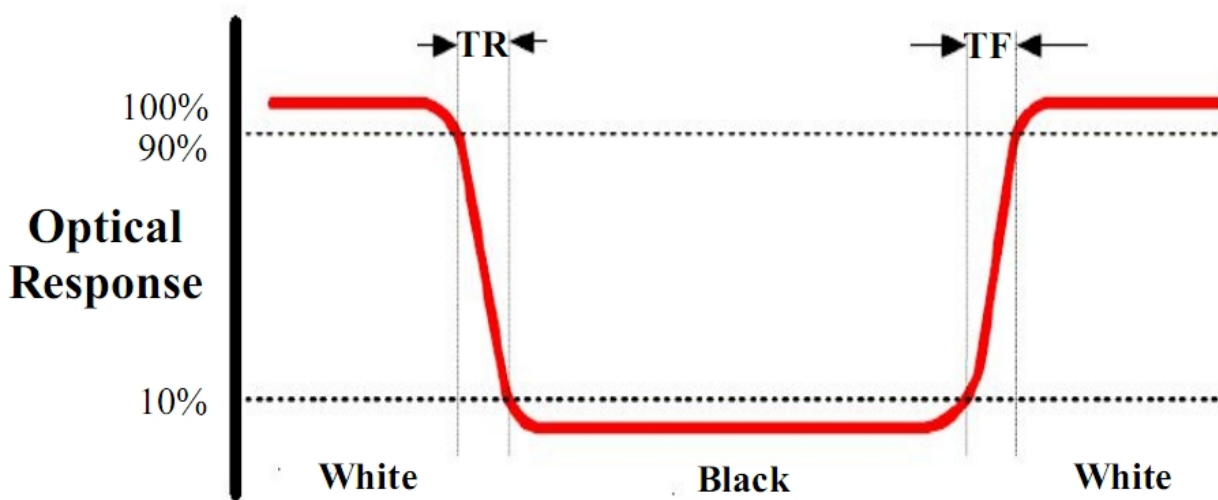

**Note 4: Definition of Luminance**

**①The Brightness Test Equipment Setup**

Field=2° (As measuring “black” image, field=2° is the best testing condition)

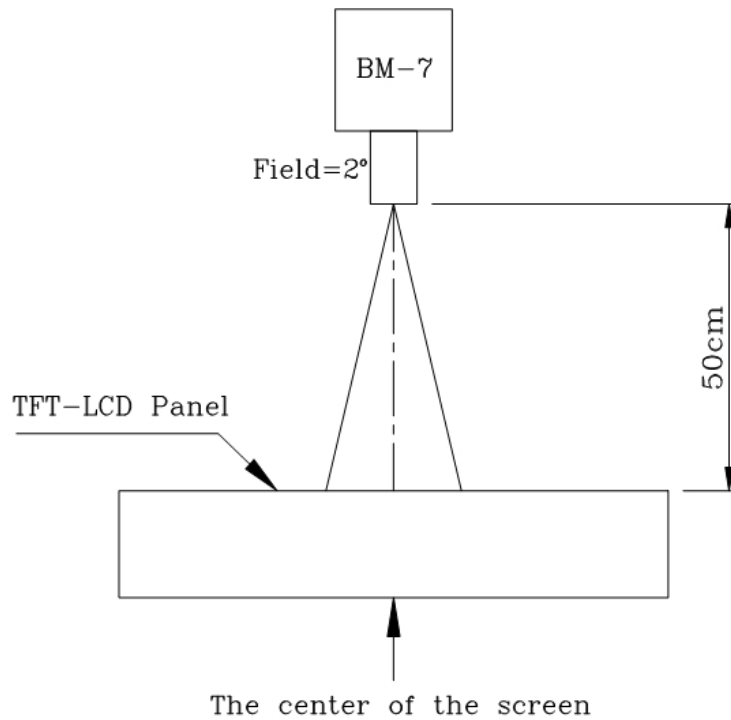

**②The Brightness Test Point Setup**

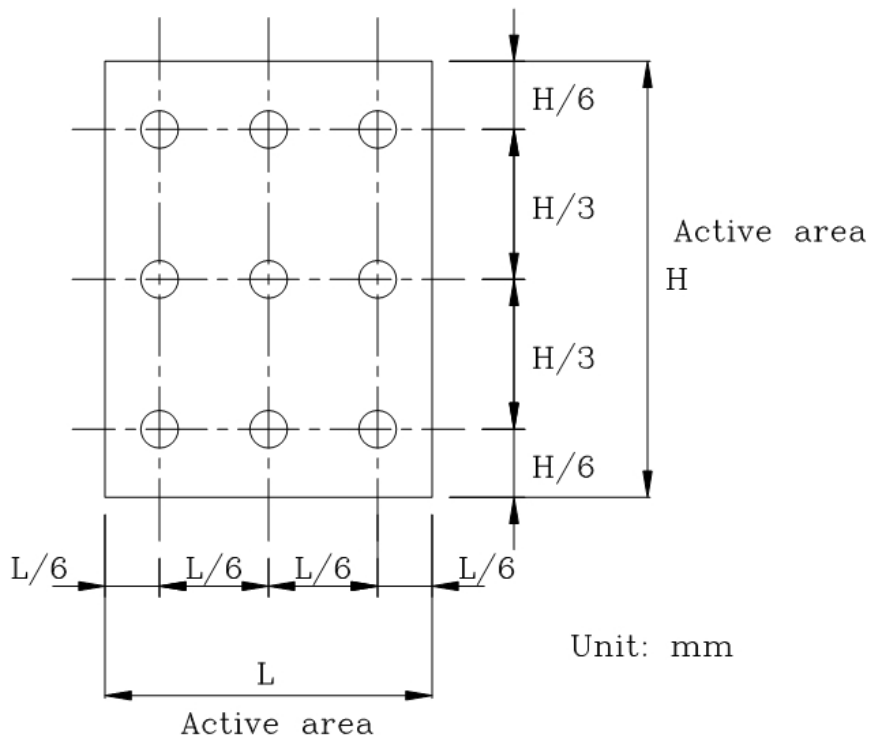

**6. ABSOLUTE MAXIMUM RATINGS**

PARAMETER	SYMBOL	MIN	Max	Unit
Supply Voltage for Analog	VCI	-0.3	4.5	V
Supply Voltage for Logic	VDDIO	-0.3	4.5	V
Supply Current (one LED)	I(LED)		30	mA
Operating Temperature	Top	-20	+70	°C
Storage Temperature	Tsr	-30	+80	°C

Note: The absolute maximum rating values of this product are not allowed to be exceeded at any times. Should a module be used with any of the absolute maximum ratings exceeded, the characteristics of the module may not be recovered, or in an extreme case, the module may be permanently destroyed.

**7. ELECTRICAL CHARACTERISTICS**

**7.1 Input Power**

ITEM	SYMBOL	MIN	Typ.	Max	Unit
Supply Voltage for Analog	VCI	3.0	3.3	3.6	V
Supply Voltage for Logic	VDDIO	3.0	3.3	3.6	V
Input Voltage	Vil	GND	-	0.3VCI	V
	Vih	0.7VCI	-	VCI	V
Input Leakage Current	Ilkg	-1		1	uA

**7.2 Backlight Driving Conditions**

Item	Symbol	Specifications			Unit	Remark
		Min	Typ.	Max		
Voltage for LED Backlight	Vf	-	19.2	-	V	Il=20mA
Current for LED Backlight	Il	-	20	30	mA	-
Power Consumption	P	-	0.384	-	W	-
Led Lifetime		30,000	50,000	-	Hr	Note

Note: brightness to be decreased to 50% of the initial value at ambient temperature TA=25°C

8. TIMING CHARACTERISTICS

8.1 RGB Timing Diagram

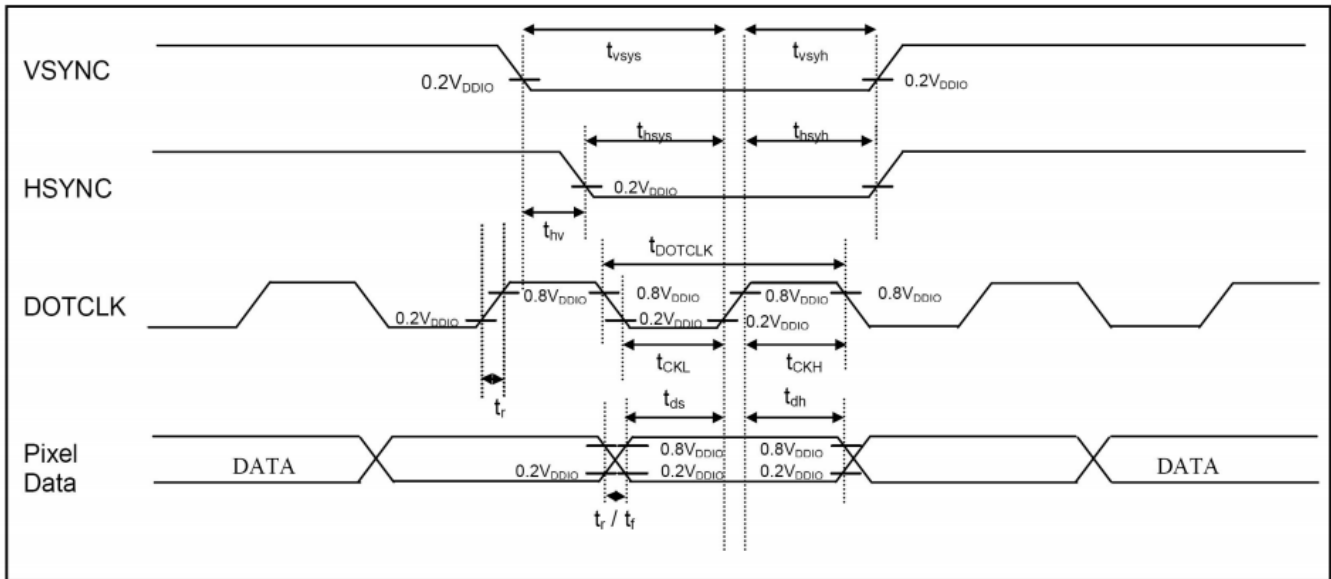

Symbol	Parameter	Min	Typ	Max	Unit
$f_{DOTCLK}$	DOTCLK Frequency (70Hz frame rate)	1	5.5	8.2	MHz
$t_{DOTCLK}$	DOTCLK Period	122	182	1000	ns
$t_{VSYs}$	Vertical Sync Setup Time	20	-	-	ns
$t_{VSYH}$	Vertical Sync Hold Time	20	-	-	ns
$t_{HSYs}$	Horizontal Sync Setup Time	20	-	-	ns
$t_{HSYH}$	Horizontal Sync Hold Time	20	-	-	ns
$t_{HV}$	Phase difference of Sync Signal Falling Edge	0	-	320	$t_{DOTCLK}$
$t_{CLK}$	DOTCLK Low Period	61	-	-	ns
$t_{CKH}$	DOTCLK High Period	61	-	-	ns
$t_{DS}$	Data Setup Time	25	-	-	ns
$t_{DH}$	Data hold Time	25	-	-	ns

Note: External clock source must be provided to DOTCLK pin of SSD2119. The driver will not operate in absence of the clocking signal.

8.2 MCU Mode Timing Diagram

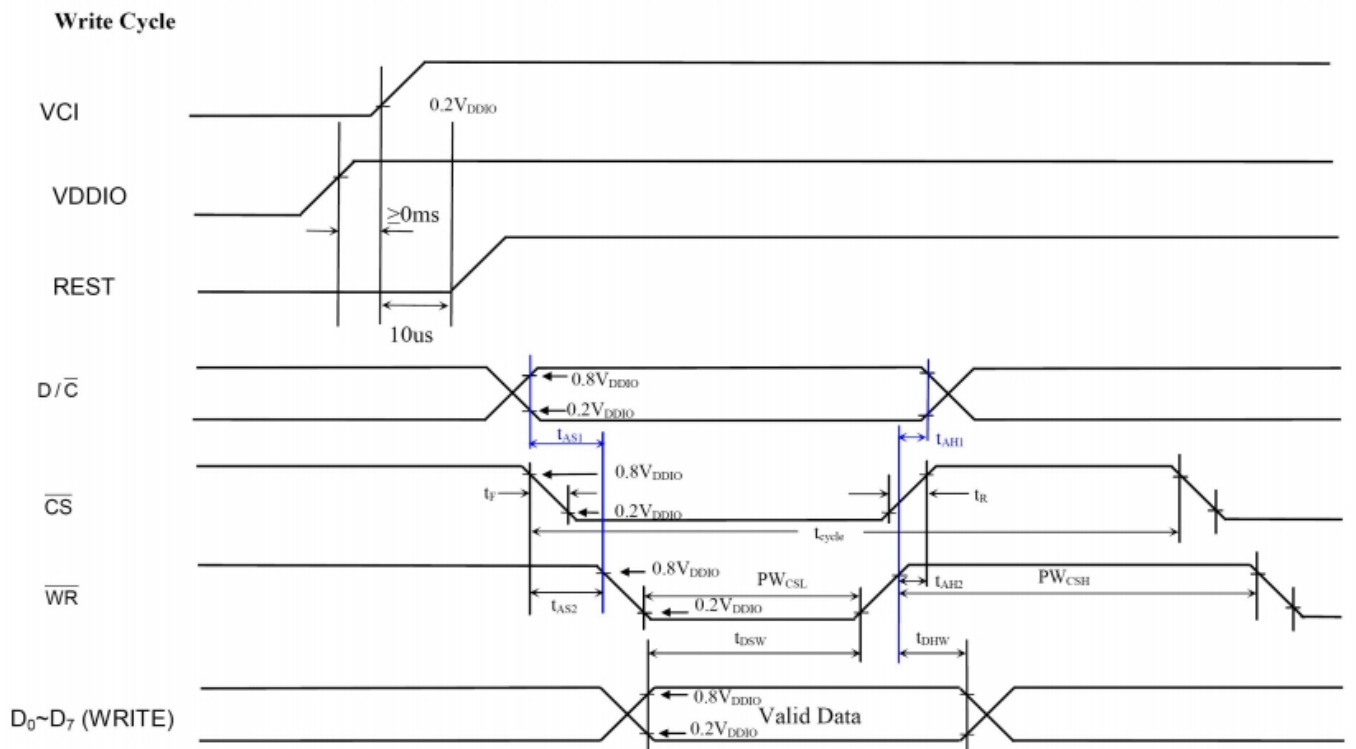

Remark: It's highly recommended that  $\overline{RD}$  remains high for the whole write cycle

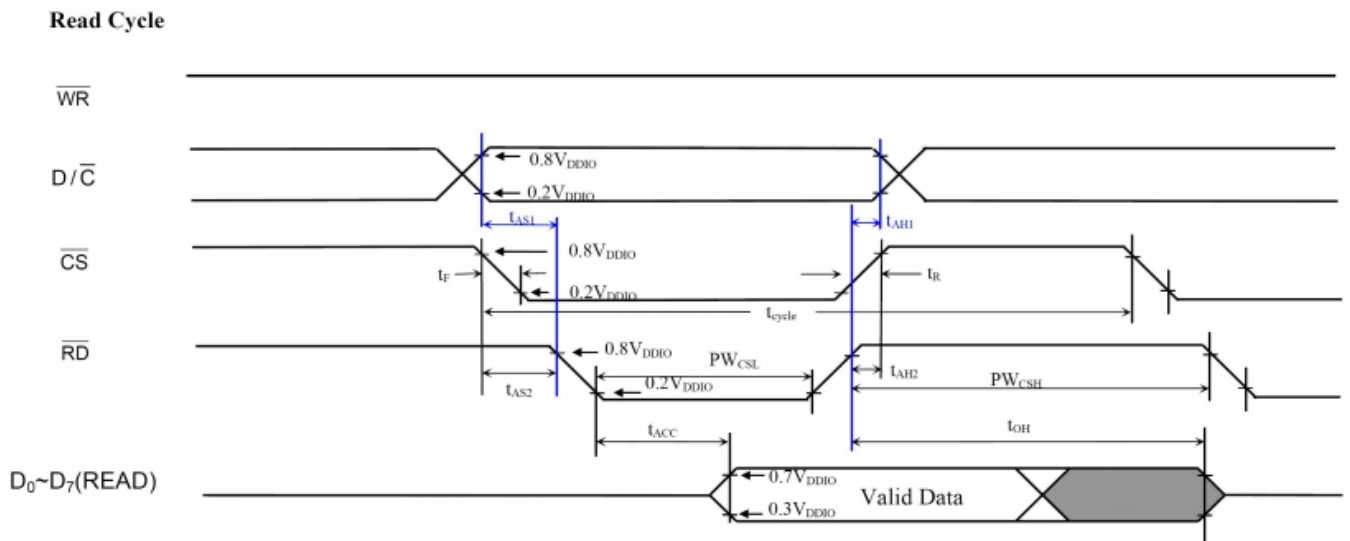

Symbol	Parameter	Min	Typ	Max	Unit
t <sub>cycle</sub>	Clock Cycle Time (write cycle)	75	-	-	ns
t <sub>cycle</sub>	Clock Cycle Time (read cycle) (Based on VOL/VOH = 0.3*VDDIO/0.7*VDDIO)	450	-	-	ns
t <sub>AS1</sub>	Address Setup Time between (R/ $\overline{W}$ ) and D/ $\overline{C}$	0	-	-	ns
t <sub>AH1</sub>	Address Hold Time between (R/ $\overline{W}$ ) and D/ $\overline{C}$	0	-	-	ns
t <sub>AS2</sub>	Address Setup Time between (R/ $\overline{W}$ ) and $\overline{CS}$	0	-	-	ns
t <sub>AH2</sub>	Address Hold Time between (R/ $\overline{W}$ ) and $\overline{CS}$	0	-	-	ns
t <sub>DSW</sub>	Data Setup Time (D0~D7, WRITE)	5	-	-	ns
t <sub>DHW</sub>	Data Hold Time (D0~D7, WRITE)	5	-	-	ns
t <sub>ACC</sub>	Data Access Time (D0~D7, READ)	250	-	-	ns
t <sub>OH</sub>	Output Hold time (D0~D7, READ)	100	-	-	ns
PW <sub>CSL</sub>	Pulse width /CS low (write cycle)	40	-	-	ns
PW <sub>CSH</sub>	Pulse width /CS high (write cycle)	25	-	-	ns
PW <sub>CSL</sub>	Pulse width /CS low (read cycle)	500	-	-	ns
PW <sub>CSH</sub>	Pulse width /CS high (read cycle)	500	-	-	ns
t <sub>R</sub>	Rise time	-	-	4	ns
t <sub>F</sub>	Fall time	-	-	4	ns

**9. RELIABILITY TEST**

**9.1 Standard Specification for Reliability of LCD Module**

No.	Test Item	Description
1	High temperature operation	The sample should be allowed to stand at 70°C for 120 hours under driving condition and then returning it to normal temperature condition, and allowing it stand for 2 hours.
2	Low temperature operation	The sample should be allowed to stand at -20°C for 120 hours under driving condition and then returning it to normal temperature condition, and allowing it stand for 2 hours.
3	High temperature storage	The sample should be allowed to stand at 80°C for 120 hours under no-load condition and then returning it to normal temperature condition, and allowing it stand for 2 hours.
4	Low temperature storage	The sample should be allowed to stand at -30°C for 120 hours under no-load condition and then returning it to normal temperature condition, and allowing it stand for 2 hours.
5	Moisture storage	The sample should be allowed to stand at 60°C, 90%RH MAX for 240 hours under no-load condition , then taking it out and drying it at normal temperature for 2 hours.
6	Thermal shock storage	The sample should be allowed to stand the following 10 cycles: -30°C for 30 minutes->normal temperature for 5 minutes-> +80°C for 30 minutes -> normal temperature for 5 minutes, as one cycle.
7	Packing vibration	Frequency Range: 10 Hz ~ 55 Hz Amplitude of Vibration: 1.5mm Sweep time:12min X, Y, Z 2 hours for each direction.
8	Packing drop	According to ASTM-D-5327
9	Electrical static discharge	Air: ±4KV 150Pf/330 Ω 5 times Contact: ±2KV 150Pf/330 Ω 5 times

\*sample size for each test item is 3-5pcs



**9.2 Testing Conditions and Inspection Criteria**

For the final test, the testing sample must be stored at room temperature for 24 hours. After the tests listed in table 9.2, standard specifications for reliability will be executed in order to ensure stability.

No.	Item	Test model	In section Criteria
1	current consumption	Refer to specification	The current consumption should conform to the product specification
2	Contrast	Refer to specification	After the tests have been executed, the contrast must be larger than half of its initial value prior to the tests.
3	Appearance	Visual inspection	Defect free

**10. LCD MODULES HANDLING PRECAUTIONS**

- The display panel is made of glass. Do not subject it to a mechanical shock by dropping it from a high place, etc.
- If the display panel is damaged and the liquid crystal substance inside it leaks out, do not get any in your mouth. If
- The substance come into contact with your skin or clothes promptly wash it off using soap and water.
- Do not apply excessive force to the display surface or the adjoining areas since this may cause the color tone to vary.
- The polarizer covering the display surface of the LCD module is soft and easily scratched. Handle this polarize carefully.
- To prevent destruction of the elements by static electricity, be careful to maintain an optimum work environment.
  - Be sure to ground the body when handling the LCD module.
  - Tools required for assembly, such as soldering irons, must be properly grounded.
  - To reduce the amount of static electricity generated, do not conduct assembly and other work under dry conditions.
  - The LCD module is coated with a film to protect the display surface. Exercise care when peeling off this protective film since static electricity may be generated.
- Storage precautions  
When storing the LCD modules, avoid exposure to direct sunlight or to the light of fluorescent lamps. Keep the modules in bags designed to prevent static electricity charging under low temperature / normal humidity conditions (avoid high temperature / high humidity and low temperatures below 0°C). Whenever possible, the LCD modules should be stored in the same conditions in which they were shipped from our company.

**11. OTHERS**

- Liquid crystals solidify at low temperature (below the storage temperature range) leading to defective orientation of liquid crystal or the generation of air bubbles (black or white). Air bubbles may also be generated if the module is subjected to a strong shock at a low temperature.
- If the LCD modules have been operating for a long time showing the same display patterns may remain on the screen as ghost images and a slight contrast irregularity may also appear. Abnormal operating status can be resumed to be normal condition by suspending use for some time. It should be noted that this phenomena does not adversely affect performance reliability.
- To minimize the performance degradation of the LCD modules resulting from caused by static electricity, etc. exercise care to avoid holding the following sections when handling the modules:
  - Exposed area of the printed circuit board
  - Terminal electrode sections.