

DISPLAY Elektronik GmbH

DATA SHEET

LCD MODULE

DEM 1280640 ADX-PW-N

Product Specification

Version : 2

28.09.2017

GENERAL SPECIFICATION

MODULE NO. :

DEM 1280640 ADX-PW-N

CUSTOMER P/N:

Version NO.	Change Description	Date
0	Original Version	15.06.2017
1	Change the LCD to Transmissive negative and change the OP./ST. Temperature	17.06.2017
2	Change Vlcd	28.09.2017

PREPARED BY: WH

DATE: 28.09.2017

APPROVED BY: MH

DATE: 28.09.2017

CONTENTS

1. FUNCTIONS & FEATURES2

2. MECHANICAL SPECIFICATIONS.....2

3. EXTERNAL DIMENSIONS3

4. BLOCK DIAGRAM.....4

5. PIN ASSIGNMENT.....5

6. BACKLIGHT ELECTRICAL/OPTICAL SPECIFICATIONS.....6

7. ABSOLUTE MAXIMUM RATINGS7

8. ELECTRICAL CHARACTERISTICS7

9. COMMAND TABLE.....10

10. LCD ARTWORT11

11. ACCEPT QUALITY LEVEL (AQL)13

12. RELIABILITY TEST13

1. FUNCTIONS & FEATURES

MODULE NAME	LCD TYPE	Remark
DEM 1280640 ADX-PW-N	ASTN Transmissive Negative Mode	---

- Viewing Direction : 6 O'clock
- Driving Scheme : 1/65Duty, 1/9Bias
- Power Supply Voltage : 3.0 Volt (typ.)
- LCD Operation Voltage : 11.0 Volt (typ.)
- Driver IC : ST7565R (Sitronix)
- Display Format : 128 x 64 Dots
- RoHS Compliant

2. MECHANICAL SPECIFICATIONS

- Module Size (Without FPC) : 58.20 x 41.70 x 5.70 mm
- View Area : 50.00 x 25.00 mm
- Active Area : 46.06 x 23.02 mm
- Dot Size : 0.34 x 0.34 mm
- Dot Gap : 0.02 mm

3. EXTERNAL DIMENSIONS (⊕ Unit: mm)

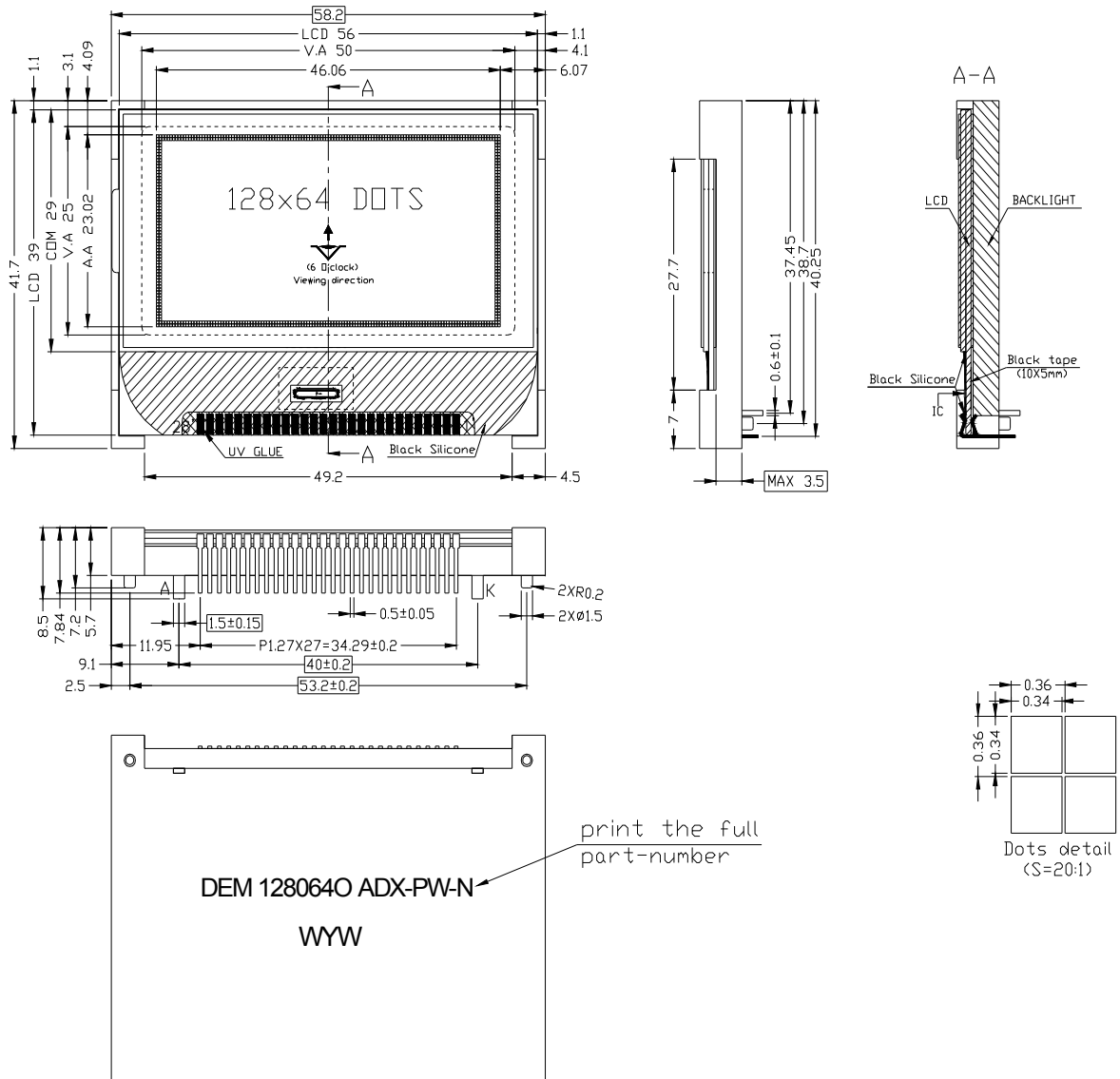

Remarks:

1. Unmarked tolerance is ±0.3
2. All materials comply with RoHs
3. []: critical dimension.

4. BLOCK DIAGRAM

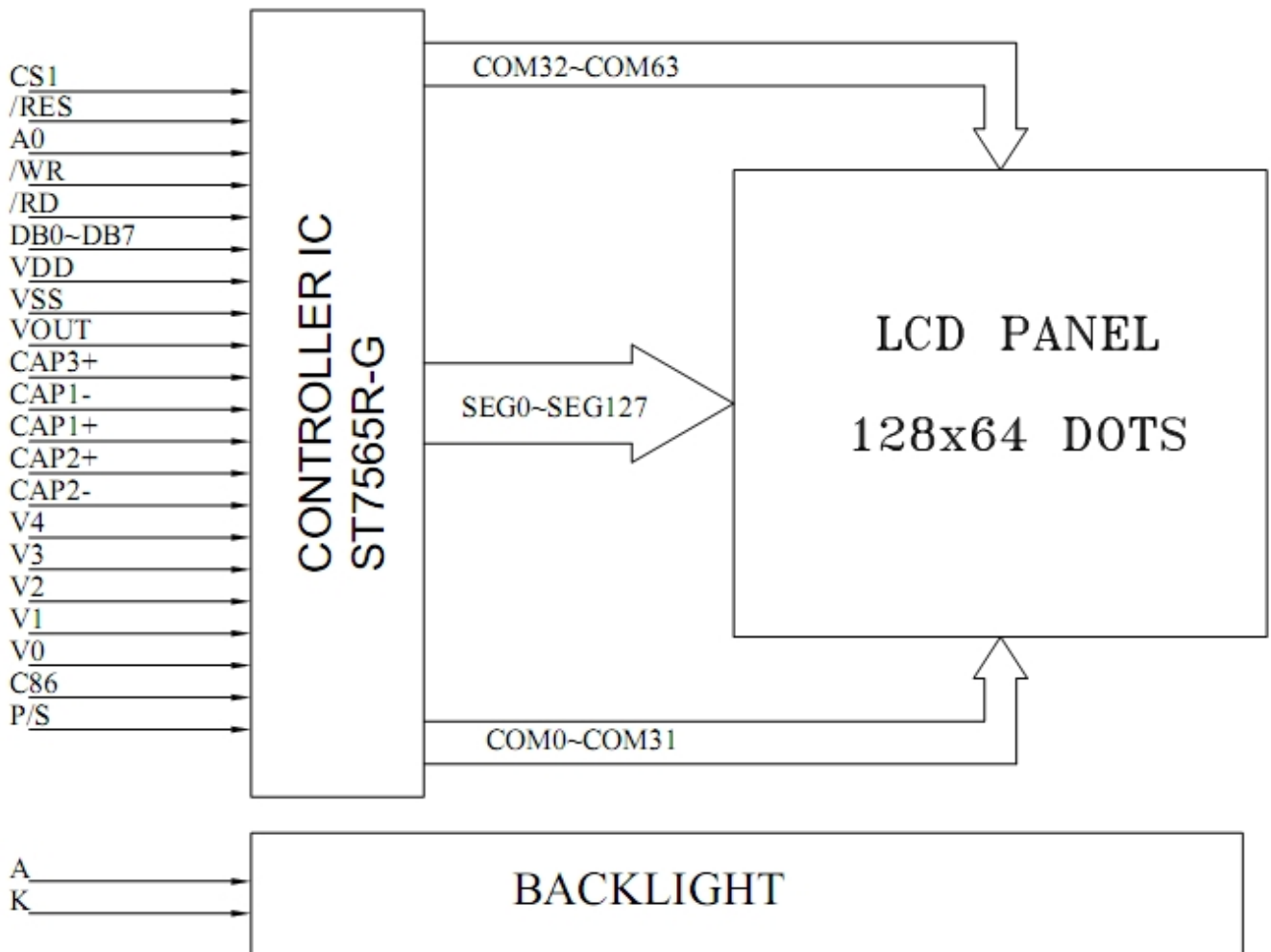

5. PIN ASSIGNMENT

Pin No.	Name	Description										
1	CS1	the chip select signal.										
2	/RES	When /RES is set to “L”, the register settings are initialized (cleared). The reset operation is performed by the /RES signal level.										
3	A0	This is connect to the least significant bit of the normal MPU address bus, and it determines whether the data bits are data or command. A0 = “H”: Indicates that D0 to D7 are display data. A0 = “L”: Indicates that D0 to D7 are control data										
4	/WR	When connected to 8080 series MPU, this pin is treated as the “/WR” signal of the 8080 MPU and is LOW-active. The signals on the data bus are latched at the rising edge of the /WR signal. When connected to 6800 series MPU, this pin is treated as the “R/W” signal of the 6800 MPU and decides the access type : When R/W = “H”: Read. When R/W = “L”: Write.										
5	/RD	When connected to 8080 series MPU, this pin is treated as the “/RD” signal of the 8080MPU and is LOW-active. The data bus is in an output status when this signal is “L”. When connected to 6800 series MPU, this pin is treated as the “E” signal of the 6800 MPU and is HIGH-active. This is the enable clock input terminal of the 6800 Series MPU.										
6~13	DB0~DB7	Data bus. This is an 8-bit bi-directional data bus that connects to an 8-bit or 16-bit standard MPU data bus.										
14	VDD	Power Supply.										
15	VSS	Ground										
16	VOUT	DC/DC voltage converter. Connect a capacitor between this terminal and VSS or VDD terminal.										
17	CAP3+	DC/DC voltage converter. Connect a capacitor between this terminal and the CAP1N terminal.										
18	CAP1-	DC/DC voltage converter. Connect a capacitor between this terminal and the CAP1P terminal.										
19	CAP1+	DC/DC voltage converter. Connect a capacitor between this terminal and the CAP1N terminal.										
20	CAP2+	DC/DC voltage converter. Connect a capacitor between this terminal and the CAP2N terminal.										
21	CAP2-	DC/DC voltage converter. Connect a capacitor between this terminal and the CAP2P terminal.										
22	V4	This is a multi-level power supply for the liquid crystal drive. The voltage Supply applied is determined by the liquid crystal cell, and is changed through the use of a resistive voltage divided or through changing the impedance using an op. amp. Voltage levels are determined based on Vss, and must maintain the relative magnitudes shown below. $V0 \geq V1 \geq V2 \geq V3 \geq V4 \geq V_{SS}$										
23	V3											
24	V2											
25	V1											
26	V0		<table border="1"> <thead> <tr> <th></th> <th>1/65 DUTY</th> </tr> </thead> <tbody> <tr> <td>V1</td> <td>$8/9 * V0, 6/7 * V0$</td> </tr> <tr> <td>V2</td> <td>$7/9 * V0, 5/7 * V0$</td> </tr> <tr> <td>V3</td> <td>$2/9 * V0, 2/7 * V0$</td> </tr> <tr> <td>V4</td> <td>$1/9 * V0, 1/7 * V0$</td> </tr> </tbody> </table>		1/65 DUTY	V1	$8/9 * V0, 6/7 * V0$	V2	$7/9 * V0, 5/7 * V0$	V3	$2/9 * V0, 2/7 * V0$	V4
	1/65 DUTY											
V1	$8/9 * V0, 6/7 * V0$											
V2	$7/9 * V0, 5/7 * V0$											
V3	$2/9 * V0, 2/7 * V0$											
V4	$1/9 * V0, 1/7 * V0$											
27	C86	This is the MPU interface selection pin.C86 = “H”: 6800 Series MPU interface. C86 = “L”: 8080 Series MPU interface.										
28	P/S	This pin configures the interface to be parallel mode or serial mode. P/S = “H”: Parallel data input/output. P/S = “L”: Serial data input.										

6. BACKLIGHT ELECTRICAL/OPTICAL SPECIFICATIONS

ELECTRICAL-OPTICAL CHARACTERISTICS

Item	Symbol	min.	typ.	max.	Unit	Condition
Forward Voltage	Vf	3.0	3.2	3.4	V	If= 20*3 mA
Power Dissipation	Pd	-	-	204	mW	If= 60 mA
Luminous Uniformity	ΔLv	70			%	MIN/MAX*100%
Luminance	Lv		420		cd/m ²	If= 60 mA T=25°C
Color Coordinate	X	0.287		0.330		
	Y	0.276		0.339		

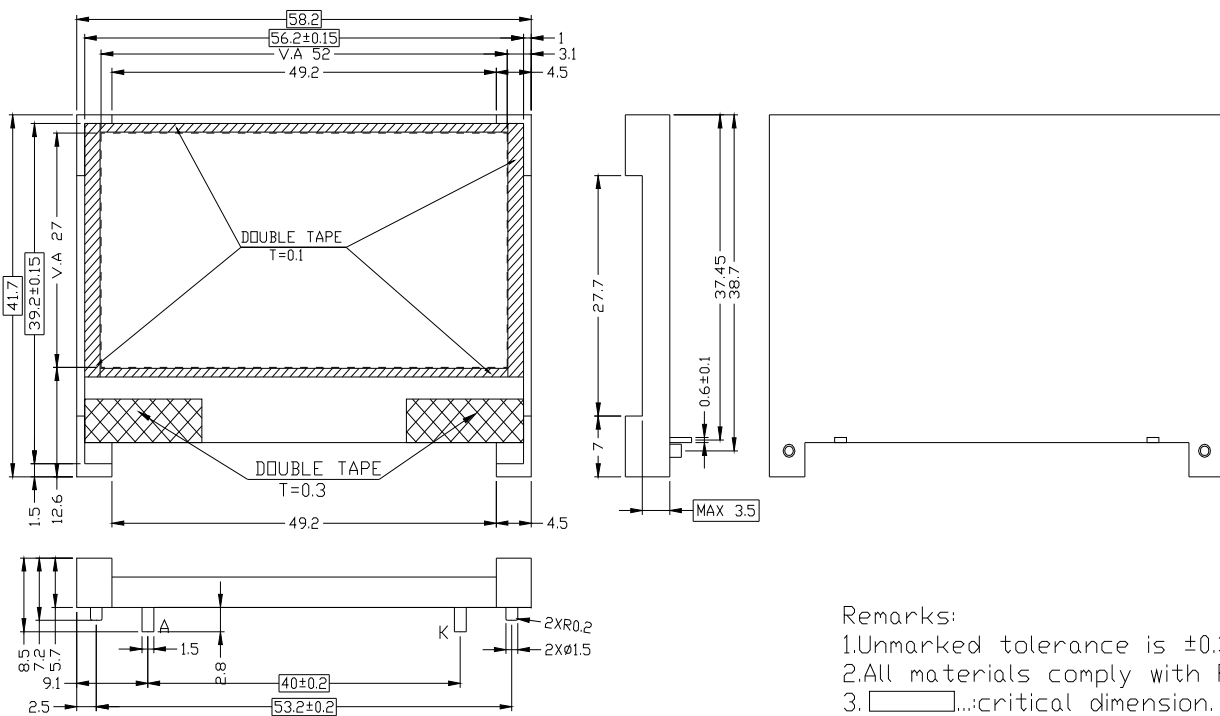

- Remarks:
- 1.Unmarked tolerance is ±0.3
 - 2.All materials comply with RoHs
 3. []...critical dimension.
 - 4.Backlight color: white
 - 5.Life time:50000 hours.

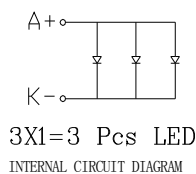

7. ABSOLUTE MAXIMUM RATINGS

Parameter	Symbol	Min	TYP.	Max	Unit
Power Supply for Logic	VDD-VSS	-0.3	---	3.6	V
Power Supply for LCD	V0-VSS	-0.3	---	13.5	V
Input Voltage	VIN	-0.3	---	VDD+0.3	V
Supply Voltage for LED Backlight	VLED	---	3.2	---	V
Operating Temperature	Top	-30	---	+80	□
Storage Temperature	Tst	-40	---	+90	□

8. ELECTRICAL CHARACTERISTICS

8.1 Electrical Characteristics (Ta=25°C, V_{DD}=3.0V)

Item	Symbol	Condition	Rating			Units
			Min.	TYP.	Max.	
Power Supply for LCM	VDD-VSS	---	2.85	3.0	3.15	V
LCD Module Driving Voltage	VO-VSS	25°C	10.7	11.0	11.3	
Input Voltage	VIL	L level	V _{SS}	---	0.2VDD	
	VIH	H level	0.8VDD	---	VDD	
Supply Current for LCM	IDD	VDD=3.0V	---	0.5	---	mA
	Ie	---	---	---	---	
	ILED	VLED=3.2V	---	60	---	

8-2 Electro-Optical Characteristics

Item	Symbol	Measuring Condition	STD. Value			Unit	
			°C	Min	Typ		Max
Recommended Operating Voltage	VLCD	$\theta = 0$ $\Phi = 0$	25	10.7	11	11.3	V
Operating Voltage	Vth	$\theta = 0$ $\Phi = 0$	0	—	—	—	
			25	10.7	11	11.3	
			40	—	—	—	
	Vsat	$\theta = 0$ $\Phi = 0$	0	—	—	—	
			25	—	—	—	
			40	—	—	—	
Response time	Tr	$\theta = 0$ $\Phi = 10$	0	—	—	—	
			25	—	218	268	
			40	—	—	—	
	Tf	$\theta = 0$ $\Phi = 10$	0	—	—	—	
			25	—	115	165	
			40	—	—	—	
Viewing Angle (Cr ≥ 2)	θ	$\Phi = 0^\circ$	25	-10	10	40	Deg
	θ	$\Phi = 180^\circ$	25	30	10	—	
	θ	$\Phi = 90^\circ$	25	30	—	—	
	θ	$\Phi = 270^\circ$	25	—	—	—	
Current Consumption	ILCD	Hz = 64	25		82		uA

8-3 AC Characteristics

System Bus Read/Write Characteristics 1 (For the 8080 Series MPU)

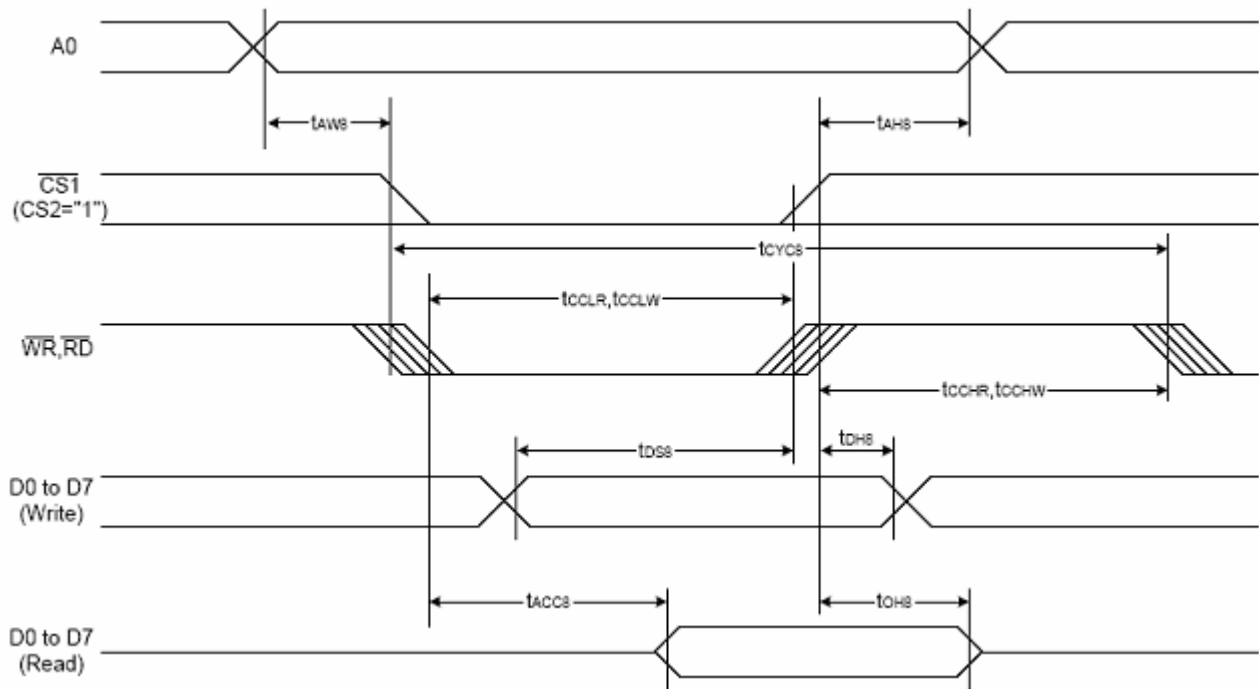

(V_{SS} = 0V, V_{DD} = 3.0V, TA=25°C)

Item	Signal	Symbol	Condition	Rating		Units
				Min.	Max.	
Address hold time	A0	t _{AHS}		0	—	Ns
Address setup time		t _{AWS}		0	—	
System cycle time		t _{CYCS}		240	—	
Enable L pulse width (WRITE)	WR	t _{CCLW}		80	—	
Enable H pulse width (WRITE)		t _{CCHW}		80	—	
Enable L pulse width (READ)	RD	t _{CCLR}		140	—	
Enable H pulse width (READ)		t _{CCHR}		80	—	
WRITE Data setup time	D0 to D7	t _{DS8}		40	—	
WRITE Address hold time		t _{DH8}		0	—	
READ access time		t _{ACC8}	CL = 100 pF	—	70	
READ Output disable time		t _{OH8}	CL = 100 pF	5	50	

System Bus Read/Write Characteristics 2 (For the 6800 Series MPU)

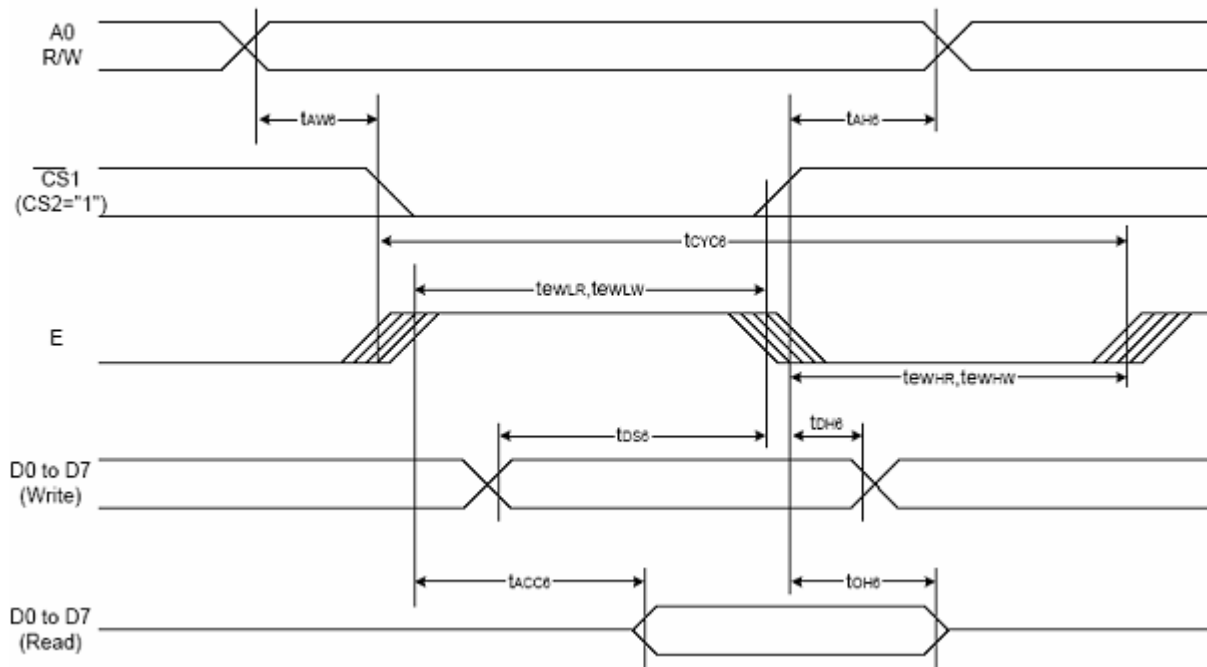

Item	Signal	Symbol	Condition	Rating		Units
				Min.	Max.	
Address hold time	A0	t_{AH6}		0	—	ns
Address setup time		t_{AW6}		0	—	
System cycle time		t_{CYC6}		240	—	
Enable L pulse width (WRITE)	WR	t_{EWLW}		80	—	
Enable H pulse width (WRITE)		t_{EWHW}		80	—	
Enable L pulse width (READ)	RD	t_{EWLR}		80	—	
Enable H pulse width (READ)		t_{EwHR}		140	—	
WRITE Data setup time	D0 to D7	t_{DS6}		40	—	
WRITE Address hold time		t_{DH6}		0	—	
READ access time		t_{ACC6}	CL = 100 pF	—	70	
READ Output disable time		t_{OH6}	CL = 100 pF	5	50	

8-4. Reset Characteristics

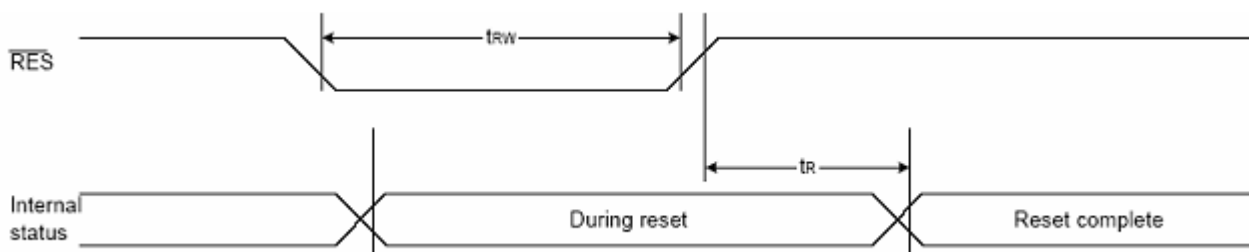

Item	Signal	Symbol	Condition	Rating			Units
				Min.	Typ.	Max.	
Reset time		t_r		—	—	1.0	us
Reset "L" pulse width	/RES	t_{rw}		1.0	—	—	us

9. COMMAND TABLE

Command	Command Code									Function		
	A0	/RD	/WR	D7	D6	D5	D4	D3	D2		D1	D0
(1) Display ON/OFF	0	1	0	1	0	1	0	1	1	1	0	LCD display ON/OFF 0: OFF, 1: ON
(2) Display start line set	0	1	0	0	1	Display start address					1	Sets the display RAM display start line address
(3) Page address set	0	1	0	1	0	1	1	Page address				Sets the display RAM page address
(4) Column address set upper bit	0	1	0	0	0	0	1	Most significant column address				Sets the most significant 4 bits of the display RAM column address.
Column address set lower bit				0	0	0	0	Least significant column address				Sets the least significant 4 bits of the display RAM column address.
(5) Status read	0	0	1	Status			0	0	0	0	0	Reads the status data
(6) Display data write	1	1	0	Write data					Writes to the display RAM			
(7) Display data read	1	0	1	Read data					Reads from the display RAM			
(8) ADC select	0	1	0	1	0	1	0	0	0	0	0	Sets the display RAM address SEG output correspondence 0: normal, 1: reverse
(9) Display normal/reverse	0	1	0	1	0	1	0	0	1	1	0	Sets the LCD display normal/reverse 0: normal, 1: reverse
(10) Display all points ON/OFF	0	1	0	1	0	1	0	0	1	0	0	Display all points 0: normal display 1: all points ON
(11) LCD bias set	0	1	0	1	0	1	0	0	0	1	0	Sets the LCD drive voltage bias ratio 0: 1/9 bias, 1: 1/7 bias (ST7565R)
(12) Read-modify-write	0	1	0	1	1	1	0	0	0	0	0	Column address increment At write: +1 At read: 0
(13) End	0	1	0	1	1	1	0	1	1	1	0	Clear read/modify/write
(14) Reset	0	1	0	1	1	1	0	0	0	1	0	Internal reset
(15) Common output mode select	0	1	0	1	1	0	0	0	*	*	*	Select COM output scan direction 0: normal direction 1: reverse direction
(16) Power control set	0	1	0	0	0	1	0	1	Operating mode		Sets internal power supply operating mode	
(17) V ₀ voltage regulator internal resistor ratio set	0	1	0	0	0	1	0	0	Resistor ratio		Sets internal resistor ratio(Rb/Ra) mode	
(18) Electronic volume mode set	0	1	0	1	0	0	0	0	0	0	1	Set the V ₀ output voltage electronic volume register
Electronic volume register set				0	0	Electronic volume value						
(19) Static indicator ON/OFF	0	1	0	1	0	1	0	1	1	0	0	0: OFF, 1: ON Set the flashing mode
Static indicator register set				0	0	0	0	0	0	0	0	
(20) Booster ratio set	0	1	0	1	1	1	1	1	0	0	0	select booster ratio 00: 2x,3x,4x 01: 5x 11: 6x
(21) Power save	0	1	0	Display OFF and display all points ON compound command							1	1
(22) NOP	0	1	0	1	1	1	0	0	0	1	1	Command for non-operation
(23) Test	0	1	0	1	1	1	1	*	*	*	*	Command for IC test. Do not use this command

10. LCD ARTWORK

10-1. LCD ARTWORK

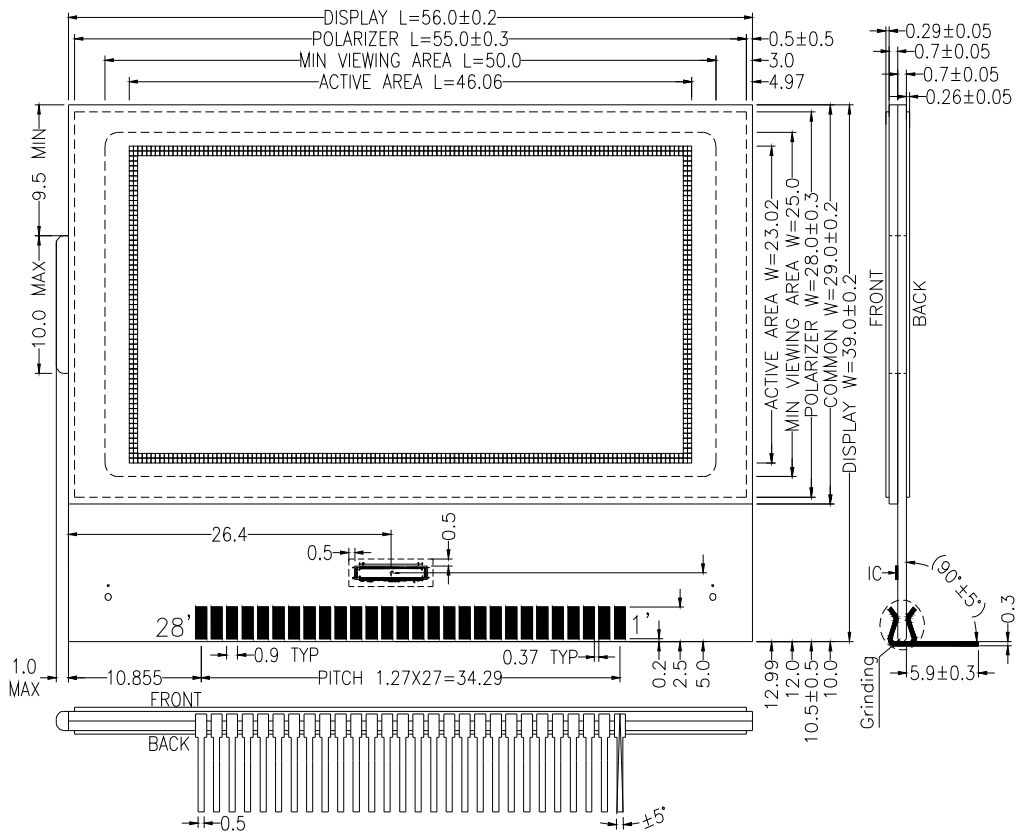

10-2. COMMON LAYOUT

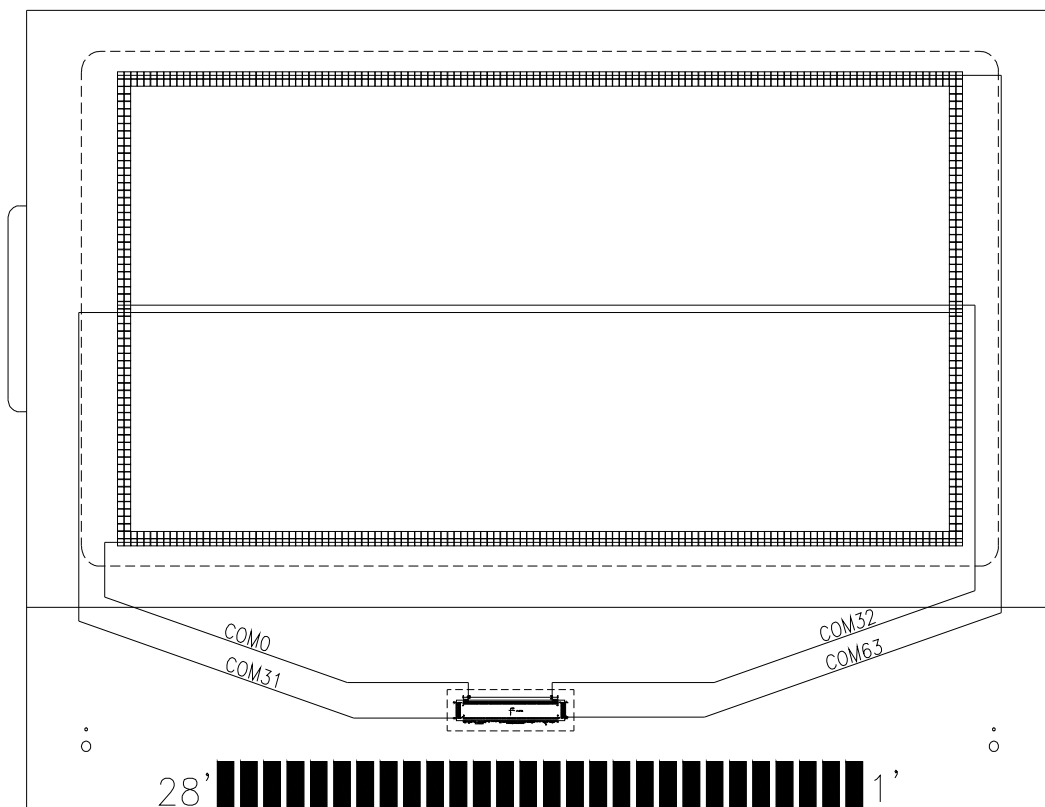

10-3. SEGMENT LAYOUT

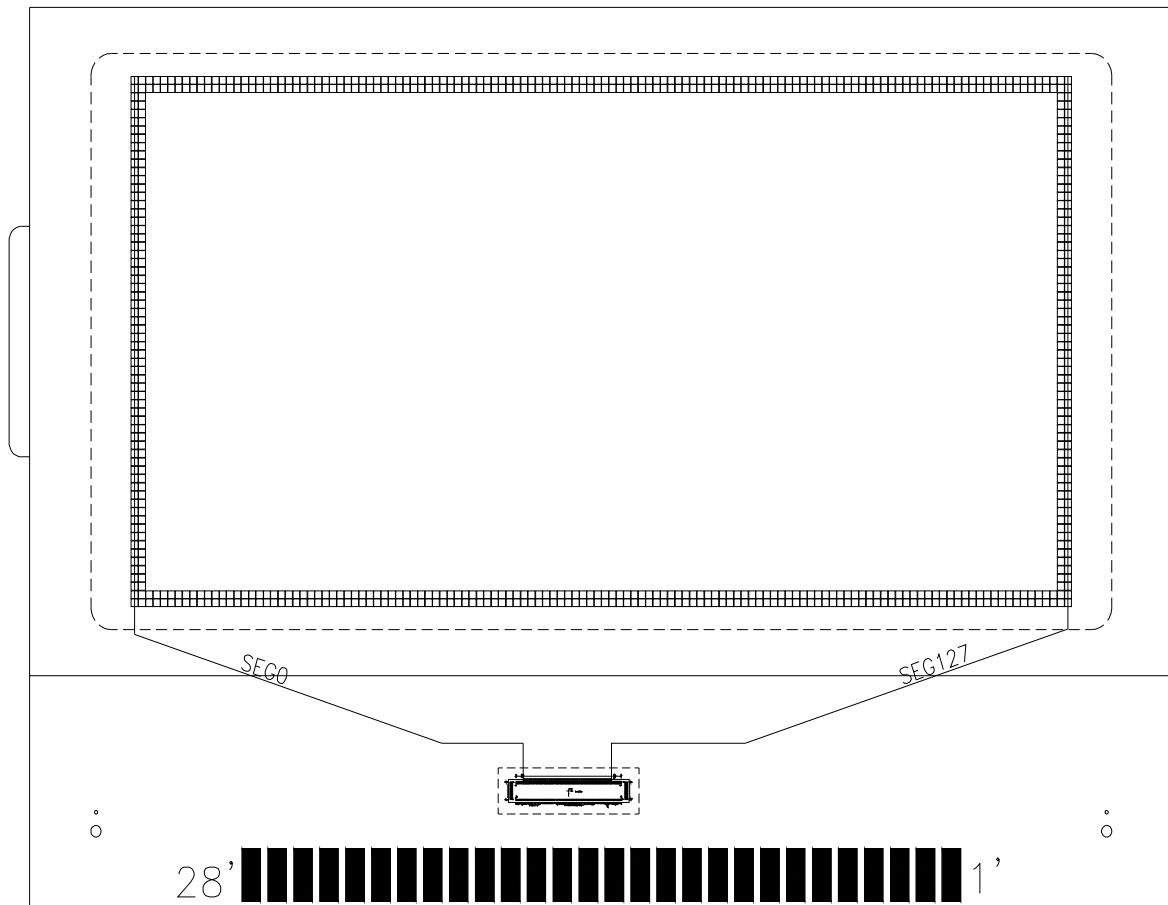

10-4. GRAPHIC DIMENSION & PAD CONFIGURATION

<u>PAD NO.</u>	<u>PAD CONFIGURATION</u>
1	COM63[R63(C0-C127)]
32	COM32[R32(C0-C127)]
33	SEG127[C127(R0-R63)]
160	SEG0[C0(R0-R63)]
161	COM0[R0(C0-C127)]
192	COM31[R31(C0-C127)]

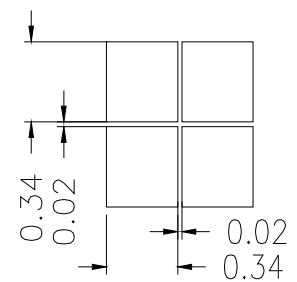

10-5. IC LAYOUT

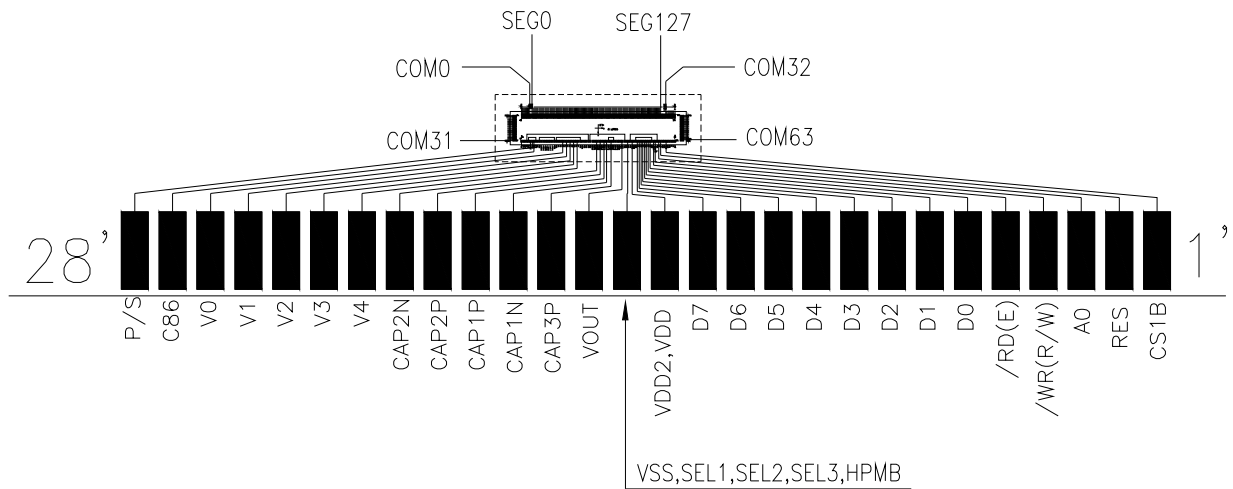

11. ACCEPT QUALITY LEVEL (AQL)

11.1 AQL Standard Value: Critical Defect =0.1, Major Defect=0.65; Minor Defect =2.5.

11.2 Inspection Plan: ANSI Z-1.4, Normal Inspection Level II, Single Sampling Plan

12. RELIABILITY TEST

Operating Lifetime: 50000 hours (at room temperature without direct irradiation of sunlight)
 Reliability characteristics shall meet following requirements.

Test Item	Test Condition
High temperature storage	+90□ x 96hrs
Low temperature storage	-40□ x 96hrs
High temperature operation	+80□ x 96hrs
Low temperature operation	-30°C x 96hrs
High temperature, High humidity	+60□ x 95%RH x 96hrs
Thermal shock	-30□ x 30min → +25□ x 10s → +80□ x 30min 5Cycles
Vibration test	Frequency x Swing x Time 40Hz x 4mm x 4hrs
Drop test	Drop height x No. of drops 1.0m x 6drops