

**DISPLAY Elektronik GmbH**

# DATA SHEET

**TFT MODULE**

**DEM 480272L TMH-PW-N**

*Product Specification*

*Version: 1*

**22.06.2016**

# GENERAL SPECIFICATION

---

MODULE NO. :

## DEM 480272L TMH-PW-N

CUSTOMER

VERSION NO.	CHANGE DESCRIPTION	DATE
0	ORIGINAL VERSION	15.06.2016
1	GENERAL SPECIFICATIONS CHANGED	22.06.2016

PREPARED BY: YH

DATE: 22.06.2016

APPROVEDBY: MH

DATE: 22.06.2016

**CONTENTS**

<b>1. GENERAL SPECIFICATIONS.....</b>	<b>2</b>
<b>2. EXTERNAL DIMENSIONS .....</b>	<b>3</b>
<b>3. BLOCK DIAGRAM .....</b>	<b>4</b>
<b>4. PIN ASSIGNMENT .....</b>	<b>5</b>
<b>5. OPTICAL CHARACTERISTICS .....</b>	<b>6</b>
<b>6. ABSOLUTE MAXIMUM RATINGS.....</b>	<b>9</b>
<b>7. ELECTRICAL CHARACTERISTICS.....</b>	<b>9</b>
<b>8. RELIABILITY TEST.....</b>	<b>12</b>
<b>9. LCD MODULES HANDLING PRECAUTIONS.....</b>	<b>13</b>
<b>10. OTHERS .....</b>	<b>13</b>

**1. GENERAL SPECIFICATIONS**

<b>Item</b>	<b>Contents</b>	<b>Unit</b>
LCD TYPE	TFT/TRANSMISSIVE	
MODULE SIZE (W*H*T)	105.50×67.20×2.90	mm
ACTIVE SIZE (W*H)	95.04*53.86	mm
PIXEL PITCH (W*H)	0.198*0.198	mm
NUMBER OF DOTS	480×RGB×272	
DIVER IC	ILI6480BQ	
INTERFACE TYPE	24-BIT/18-BIT — RGB	
TOP POLARIZER TYPE	ANTI-GLARE	
RECOMMEND VIEWING DIRECTION	12:00	O'CLOCK
GRAY SCALE INVERSION DIRECTION	6:00	O'CLOCK
COLORS	16.7 Million	
BACKLIGHT TYPE	9-DIES WHITE LED	
TOUCH PANEL TYPE	WITHOUT	
APPROX.WEIGHT	45	g

2. EXTERNAL DIMENSIONS

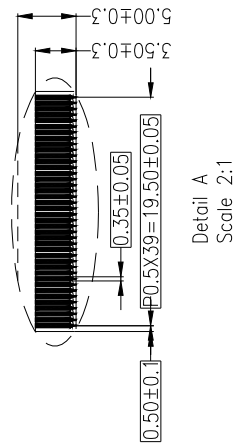
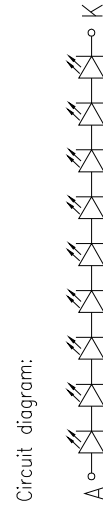
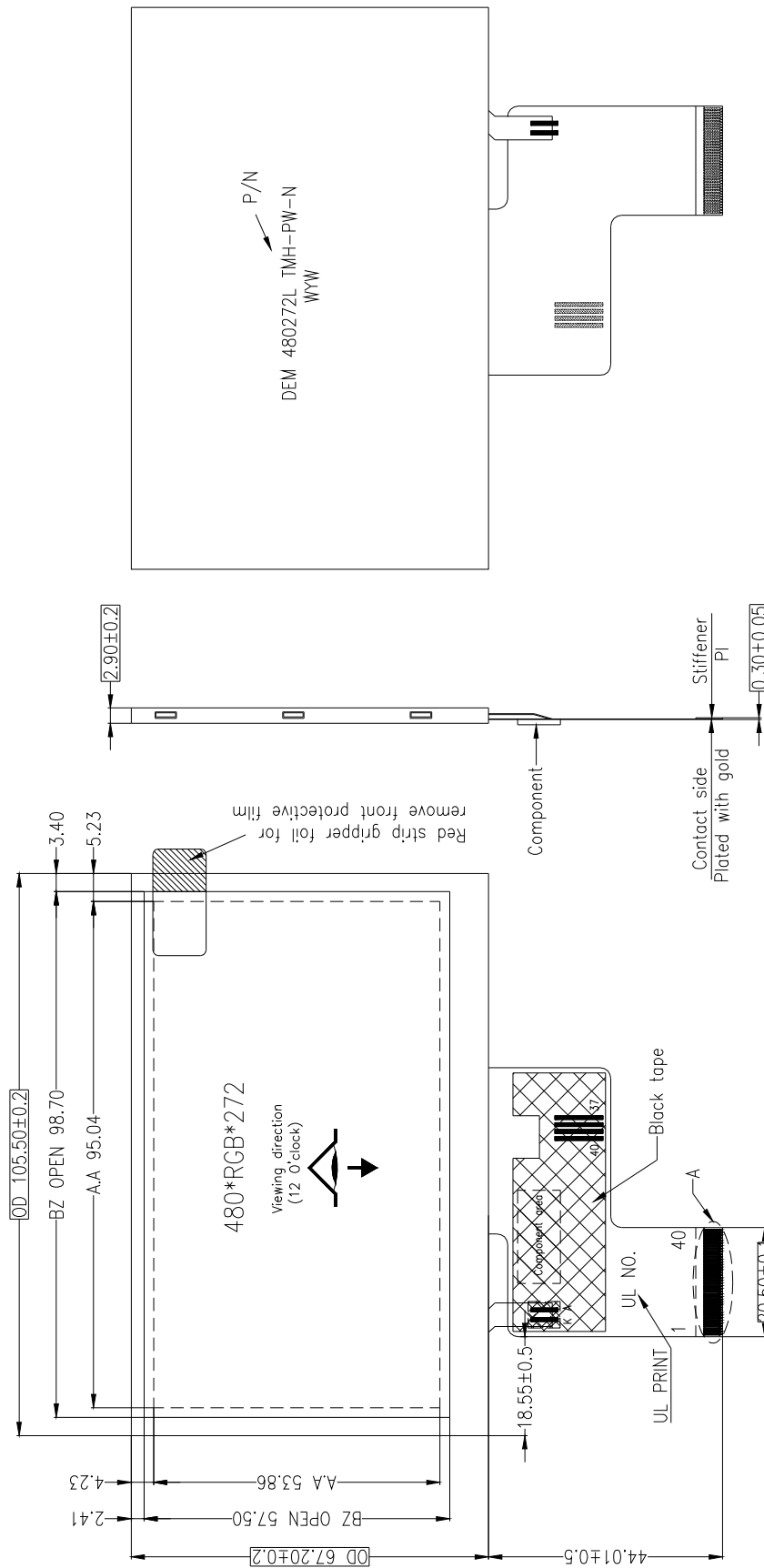

- Remark:
1. Unmarked tolerance is  $\pm 0.3$
  2. All materials comply with RoHS
  3.  ...:critical dimension
  4. WW:Product date code printing  
Format: Y:year ,WW:week

3. BLOCK DIAGRAM

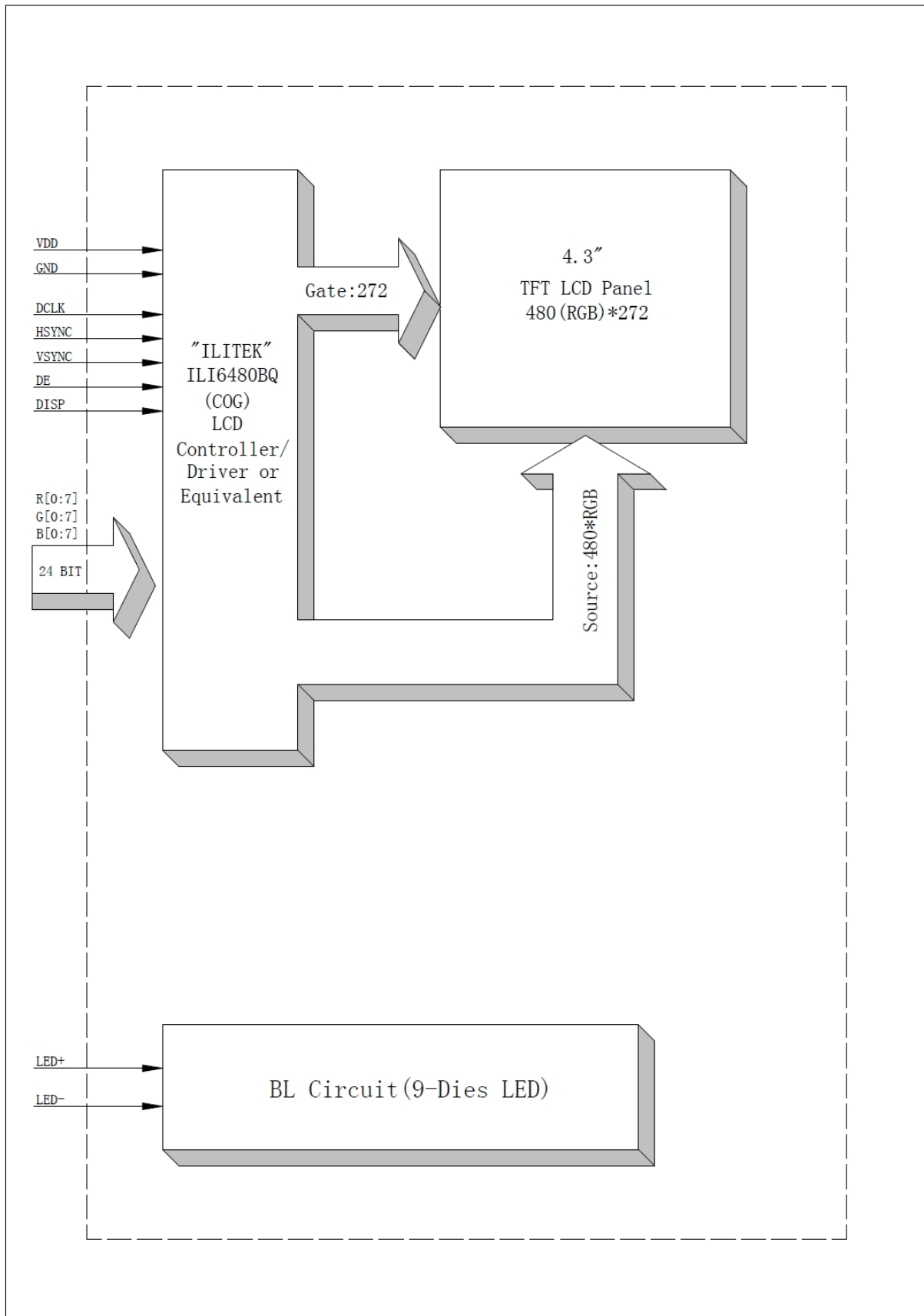

**4. PIN ASSIGNMENT**

<b>Pin No.</b>	<b>Symbol</b>	<b>Description</b>
1	LED-	Cathode of LED backlight
2	LED+	Anode of LED backlight
3	GND	Power ground
4	VDD	Power supply
5~12	R0~R7	8-bit digital Red data input,
13~20	G0~G7	8-bit digital Green data input,
21~28	B0~B7	8-bit digital Blue data input,
29	GND	Power ground
30	DCLK	Clock signal; latching data at the falling edge
31	DISP	Display control / standby mode selection. DISP = "Low" : Standby; DISP = "High" : Normal display(Default)
32	HSYNC	Horizontal sync signal; negative polarity
33	VSYNC	Vertical sync signal; negative polarity
34	DE	Data input enable. Active High to enable the data input.
35	NC	No connection.
36	GND	Power ground
37	NC	No connection.
38	NC	No connection.
39	NC	No connection.
40	NC	No connection.

**5. OPTICAL CHARACTERISTICS**

ITEM	SYMBOL	CONDITIONS	SPECIFICATIONS			UNIT	NOTE
			MIN	TYP.	MAX		
Luminance	L	$I_L = 20\text{mA}$	500	550	600	Cd/m <sup>2</sup>	
Contrast Ratio	CR	$\theta = 0^\circ$	400	500			
Response Time	T <sub>ON</sub>	25°C		10	20	ms	
	T <sub>OFF</sub>			15	30		
CIE Color Coordinate	Red	X <sub>R</sub>	Viewing normal angle				
		Y <sub>R</sub>					
	Green	X <sub>G</sub>					
		Y <sub>G</sub>					
	Blue	X <sub>B</sub>					
		Y <sub>B</sub>					
	White	X <sub>W</sub>		0.27	0.31	0.35	
		Y <sub>W</sub>		0.31	0.35	0.39	
Viewing Angle	Hor.	$\theta_{X+}$	$CR \geq 10$	60	70	Degree	
		$\theta_{X-}$		60	70		
	Ver.	$\theta_{Y+}$		40	50		
		$\theta_{Y-}$		60	70		
Uniformity	Un		80			%	



**Note 1: Definition of Viewing Angle  $\theta_x$  and  $\theta_y$ :**

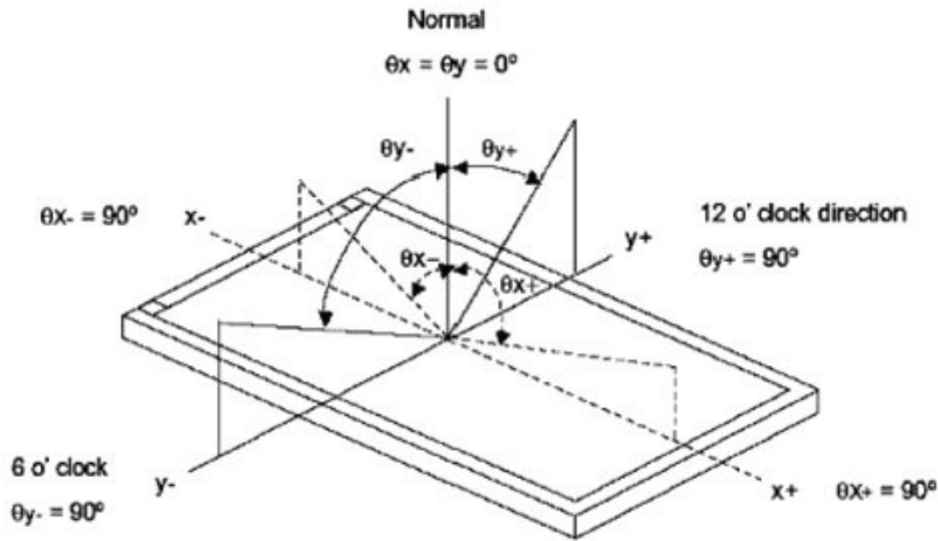

**Note 2: Definition of contrast ratio CR:**

$$CR = \frac{\text{Luminance of white state}}{\text{Luminance of black state}}$$

**Note 3: Definition of Response Time( $T_r, T_f$ )**

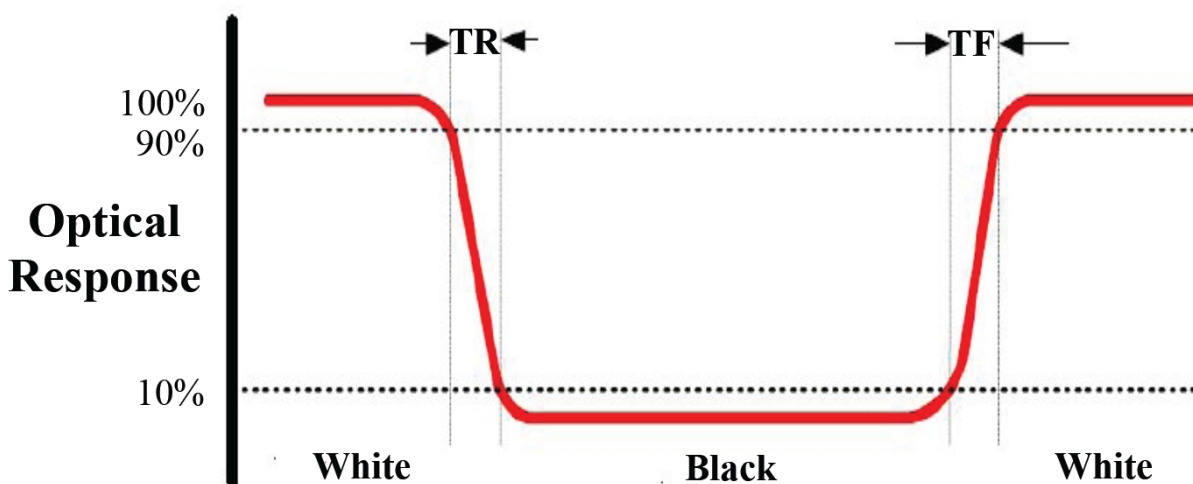

**Note 4: Definition of Luminance**

**①The Brightness Test Equipment Setup**

Field=2° (As measuring “black” image, field=2° is the best testing condition)

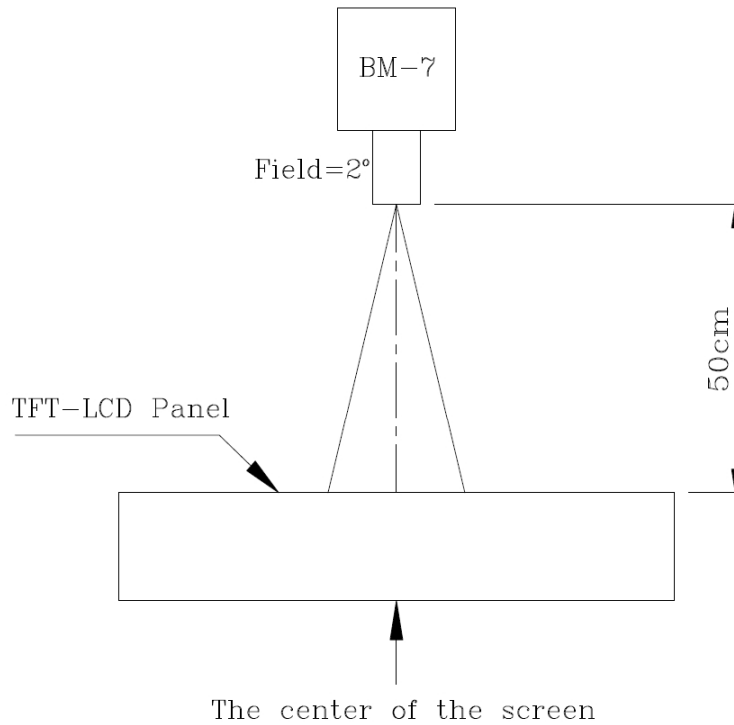

**②The Brightness Test Point Setup**

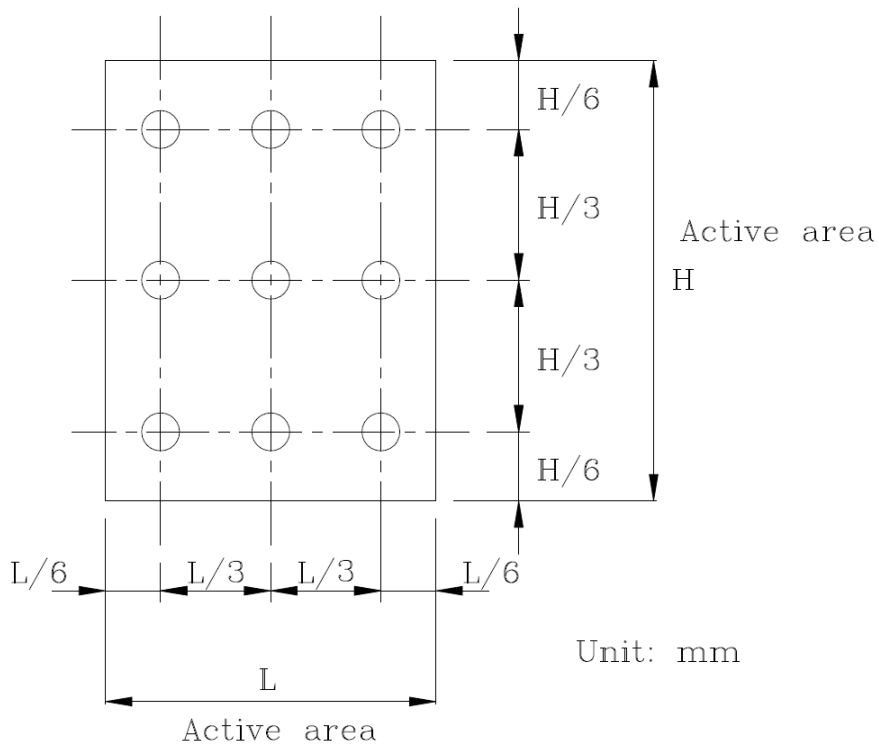

## 6. ABSOLUTE MAXIMUM RATINGS

Parameter	Symbol	Min	Max	Unit
Supply voltage for analog	VDD	-0.3	4.5	V
Supply voltage for logic	VDD	-0.3	4.5	V
Supply current (One LED)	I <sub>LED</sub>		30	mA
Operating temperature	T <sub>OP</sub>	-20	+70	°C
Storage temperature	T <sub>ST</sub>	-30	+80	°C

Note : The absolute maximum rating values of this product are not allowed to be exceeded at any times. Should a module be used with any of the absolute maximum ratings exceeded, the characteristics of the module may not be recovered, or in an extreme case, the module may be permanently destroyed.

## 7. ELECTRICAL CHARACTERISTICS

### 7.1 INPUT POWER

Item	Symbol	Min	Typ.	Max	Unit	Applicable terminal
Supply Voltage for Analog	VDD	3.0	3.3	3.6	V	
Supply Voltage for Logic	VDD	3.0	3.3	3.6	V	
Input Voltage	V <sub>IL</sub>	GND	-	0.3VCC	V	
	V <sub>IH</sub>	0.7 VCC	-	VCC		
Input leakage Current	I <sub>LKG</sub>	-1		1	μA	

### 7.2 BLACKLIGHT DRIVING CONDITIONS

Item	Symbol	Value			Unit	Remark
		Min.	Typ.	Max.		
Voltage for LED Backlight	V <sub>F</sub>	27	28.8	30.6	V	I <sub>L</sub> =20mA
Current for LED Backlight	I <sub>L</sub>	15	20	25	mA	
Power Consumption	P		0.576		W	
LED Life Time		50,000			Hr	Note

**Note:** Brightness to be decreased to 50% of the initial value at ambient temperature TA=25°C

7.3 TIMING CHARACTERISTICS

7.3.1 PARALLEL RGB MODE TIMING DIAGRAM

(HV Mode)

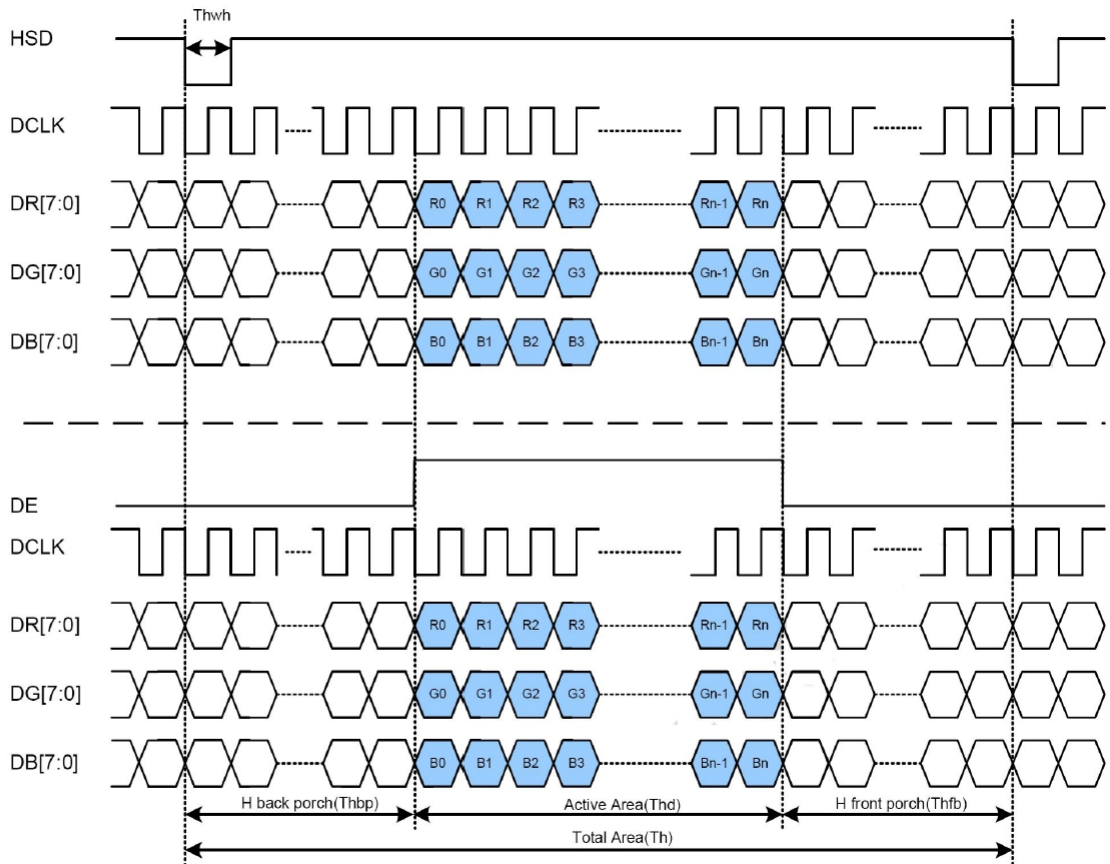

(DE Mode)

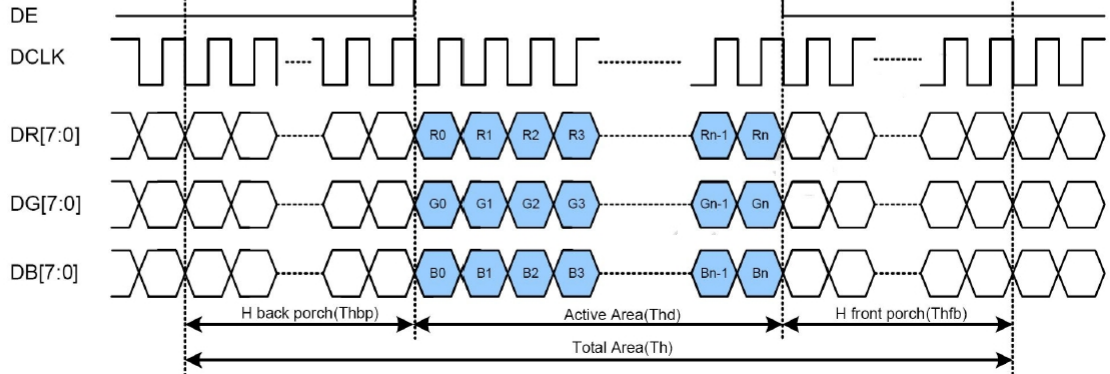

7.3.2 PARALLEL RGB TIMING TABLE

Parameter	Symbol	Value			Unit
		Min.	Typ.	Max.	
DCLK frequency	fclk	5	9	12	MHz
VSD period time	$T_v$	277	288	400	H
VSD display area	$T_{vd}$	272			H
VSD back porch	$T_{vb}$	3	8	31	H
VSD front porch	$T_{vfp}$	2	8	97	H
HSD period time	$T_h$	520	525	800	DCLK
HSD display area	$T_{hd}$	480			DCLK
HSD back porch	$T_{hbp}$	36	40	255	DCLK
HSD front porch	$T_{hfp}$	4	5	65	DCLK

7.3.3 POWER ON/OFF SEQUENCE

Power on

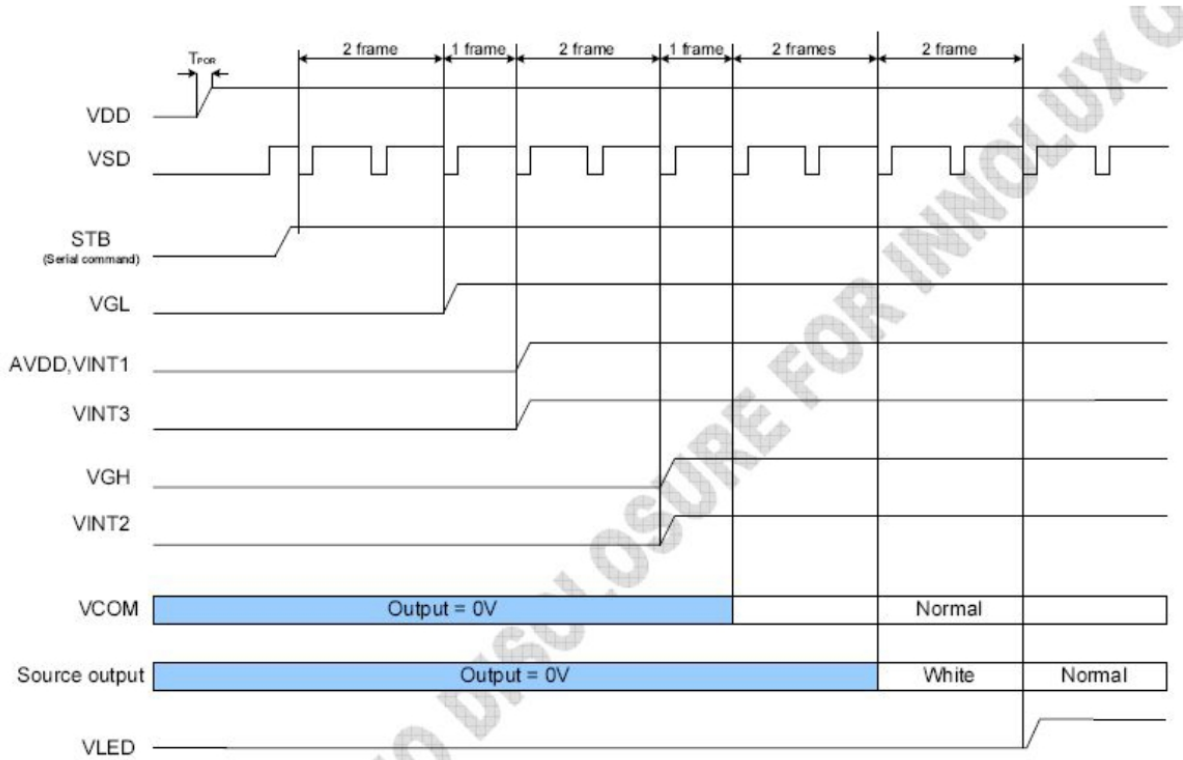

Power off

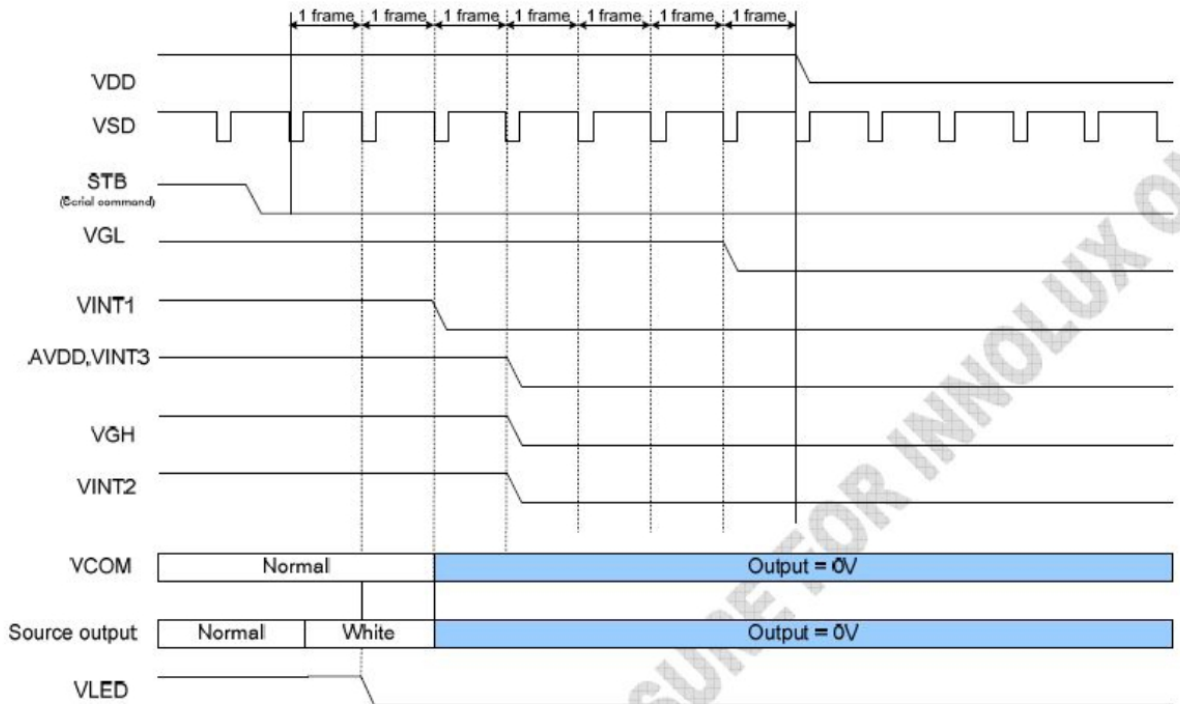

**8. RELIABILITY TEST**

<b>No.</b>	<b>Item</b>	<b>Description</b>
01	High temperature operation	The sample should be allowed to stand at 70°C for 120 hours under driving condition and then returning it to normal temperature condition, and allowing it stand for 2 hours.
02	Low temperature operation	The sample should be allowed to stand at -20°C for 120 hours under driving condition and then returning it to normal temperature condition, and allowing it stand for 2 hours.
03	High temperature storage	The sample should be allowed to stand at 80°C for 240 hours under no-load condition, and then returning it to normal temperature condition, and allowing it stand for 2 hours.
04	Low temperature storage	The sample should be allowed to stand at -30°C for 240 hours under no-load condition, then returning it to normal temperature condition, and allowing it stand for 2 hours.
05	Moisture storage	The sample should be allowed to stand at 60°C,90%RH MAX for 240 hours under no-load condition, then taking it out and drying it at normal temperature for 2 hours.
06	Operate at high temperature and humidity	60°C,90%RH,240hr
07	Thermal shock storage	The sample should be allowed to stand the following 10 cycles : -30°C for 30 minutes → normal temperature for 5 minutes → +80°C for 30 minutes → normal temperature for 5 minutes, as one cycle.
08	Packing vibration	Frequency range : 10Hz ~ 55Hz Amplitude of vibration : 1.5mm Sweep time: 12 min X,Y,Z 2 hours for each direction.
09	Packing drop test	According to ASTM-D-5327.
10	Electrical Static	Air: ±4KV 150pF/330Ω 5 times



**9. LCD MODULES HANDLING PRECAUTIONS**

- The display panel is made of glass. Do not subject it to a mechanical shock by dropping it from a high place, etc.
- If the display panel is damaged and the liquid crystal substance inside it leaks out, do not get any in your mouth. If the substance come into contact with your skin or clothes promptly wash it off using soap and water.
- Do not apply excessive force to the display surface or the adjoining areas since this may cause the color tone to vary.
- The polarizer covering the display surface of the LCD module is soft and easily scratched. Handle this polarize carefully.
- To prevent destruction of the elements by static electricity, be careful to maintain an optimum work environment.
  - Be sure to ground the body when handling the LCD module.
  - Tools required for assembly, such as soldering irons, must be properly grounded.
  - To reduce the amount of static electricity generated, do not conduct assembly and other work under dry conditions.
  - The LCD module is coated with a film to protect the display surface. Exercise care when peeling off this protective film since static electricity may be generated.
- Storage precautions  
When storing the LCD modules, avoid exposure to direct sunlight or to the light of fluorescent lamps. Keep the modules in bags designed to prevent static electricity charging under low temperature / normal humidity conditions (avoid high temperature / high humidity and low temperatures below 0°C). Whenever possible, the LCD modules should be stored in the same conditions in which they were shipped from our company.

**10. OTHERS**

- Liquid crystals solidify at low temperature (below the storage temperature range) leading to defective orientation of liquid crystal or the generation of air bubbles (black or white). Air bubbles may also be generated if the module is subjected to a strong shock at a low temperature.
- If the LCD modules have been operating for a long time showing the same display patterns may remain on the screen as ghost images and a slight contrast irregularity may also appear. Abnormal operating status can be resumed to be normal condition by suspending use for some time. It should be noted that this phenomena does not adversely affect performance reliability.
- To minimize the performance degradation of the LCD modules resulting from caused by static electricity, etc. exercise care to avoid holding the following sections when handling the modules:
  - Exposed area of the printed circuit board
  - Terminal electrode sections.