

# G5NB

PCB Power Relay



## A Miniature Relay with 1-pole 3A/5A Switching Capability and 10 kV Impulse Withstand Voltage

- Highly efficient magnetic circuit for high sensitivity (200 mW).
- Small, yet provides 10-kV impulse withstand voltage (between coil and contacts).
- Standard model conforms to UL/CSA/VDE standards.
- Satisfies EN61010 reinforced insulation requirements.
- IEC/EN 60335-1 conformed. (-HA Model)

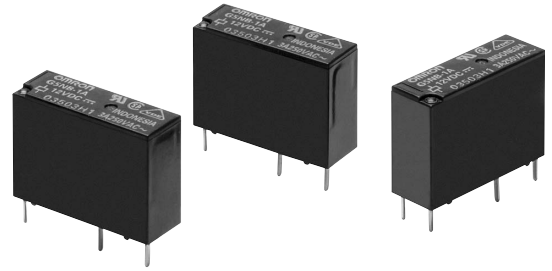

RoHS Compliant

### Model Number Legend

G5NB-□□□-□-□  
1 2 3 4 5

#### 1. Number of Poles

1: 1-pole

#### 2. Contact Form

A: SPST-NO (1a)

#### 3. Enclosure rating

None: Flux protection

4 :Sealed

#### 4. Classification

None: Standard

E :High-capacity

#### 5. Market Code

None: General purpose

HA :Home Appliance according to IEC/EN60335-1

### Application Examples

- Water heaters
- Refrigerators
- Air conditioners
- Home appliances
- Small electric appliances

### Ordering Information

Terminal Shape	Market Code	Classification	Contact form	Enclosure rating	Model	Rated coil voltage	Minimum packing unit
PCB terminals	General purpose	Standard	SPST-NO (1a)	Flux protection	G5NB-1A	5VDC	100 pcs/Tray
				Sealed	G5NB-1A4	12VDC	
		Flux protection		G5NB-1A-E	18VDC		
		Sealed		G5NB-1A4-E	24VDC		
	Home Appliance	High-capacity		Flux protection	G5NB-1A-E-HA	12VDC	
						24VDC	

Note. When ordering, add the rated coil voltage to the model number.

Example: G5NB-1A 5 VDC

Rated coil voltage

### Ratings

#### Coil

Item	Rated current (mA)	Coil resistance (Ω)	Must operate voltage (V)	Must release voltage (V)	Max. voltage (V)	Power consumption (mW)
Rated voltage			% of rated voltage			
5 VDC	40	125	75% max.	10% min.	Standard: 180% (at 23°C) High-capacity: 170% (at 23°C)	Approx. 200
12 VDC	16.7	720				
18 VDC	11.1	1,620				
24 VDC	8.3	2,880				

Note 1. The rated current and coil resistance are measured at a coil temperature of 23°C with a tolerance of ±10%.

Note 2. The operating characteristics are measured at a coil temperature of 23°C.

Note 3. The "Max. voltage" is the maximum voltage that can be applied to the relay coil.

#### Contacts

Item	Load	Resistive load	
		Standard	High-capacity
Contact Type		Single	
Contact material		Ag-alloy (Cd free)	
Rated load		3 A at 125 VAC	5 A at 250 VAC
		3 A at 30 VDC	3 A at 30 VDC
Rated carry current		3 A	5 A
Max. switching voltage		250 VAC, 30 VDC	
Max. switching current		3 A	5 A

## Characteristics

Contact resistance *1	100 mΩ max.	
Operate time	10 ms max.	
Release time	10 ms max.	
Insulation resistance *2	1,000 MΩ min.	
Dielectric strength	Between coil and contacts	4,000 VAC, 50/60 Hz for 1 min
	Between contacts of the same polarity	750 VAC, 50/60 Hz for 1 min
Impulse withstand voltage	Between coil and contacts	10 kV (1.2 x 50 μs)
Vibration resistance	Destruction	10 to 55 to 10 Hz, 0.75 mm single amplitude (1.5 mm double amplitude)
	Malfuction	10 to 55 to 10 Hz, 0.75 mm single amplitude (1.5 mm double amplitude)
Shock resistance	Destruction	1,000 m/s <sup>2</sup>
	Malfuction	100 m/s <sup>2</sup>
Durability	Mechanical	5,000,000 operations min.
	Electrical (resistive load)	Standard (G5NB-1A, -1A4) 200,000 operations at 125 VAC, 3A 200,000 operations at 30 VDC, 3A High-capacity (G5NB-1A-E, -1A4-E) 100,000 operations at 250 VAC, 5A 200,000 operations at 30 VDC, 3A (with a rated load at 1,800 operations/hour)
Failure rate (P level) (reference value) *3	DC5V 10mA	
Ambient operating temperature	-40°C to 70°C (with no icing or condensation)	
Ambient operating humidity	5% to 85%	
Weight	Approx. 4 g	

Note. Values in the above table are the initial values at 23°C.

\*1. Measurement conditions: 5 VDC, 1 A, voltage drop method

\*2. Measurement conditions: Measured at the same points as the dielectric strength using a 500 VDC ohmmeter.

\*3. This value was measured at a switching frequency of 120 operations/min.

## Actual Load Life (Reference Values)

- 120 VAC** motor and lamp load  
2.5A surge and 0.5A normal:  
250,000 operations min. (at 23°C)
- 160 VDC** valve load (with varistor)  
0.24A:  
250,000 operations min. (at 23°C)
- 140 VAC** pump load  
Inrush: 5.4 A (o-p), Steady state: 1.6 A  
200,000 operations min. (Ambient temperature: 23°C)
- 100 VAC** motor load  
Inrush: 10.7 A (o-p), Steady state: 1.1 A  
200,000 operations min. (Ambient temperature: 23°C)

## Engineering Data

### Maximum Switching Capacity

#### Standard models

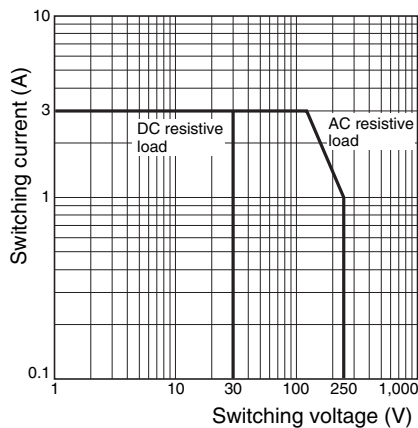

#### High-capacity models

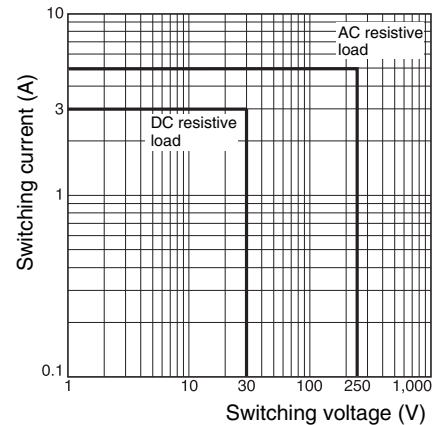

## ●Durability

### Standard models

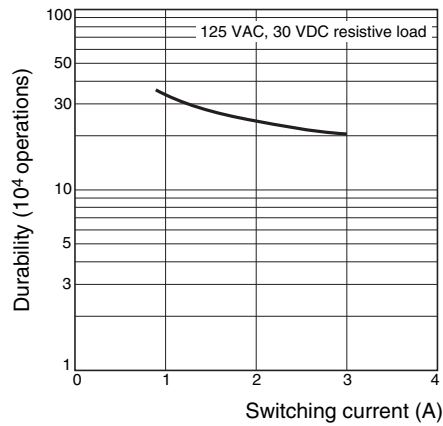

### High-capacity models

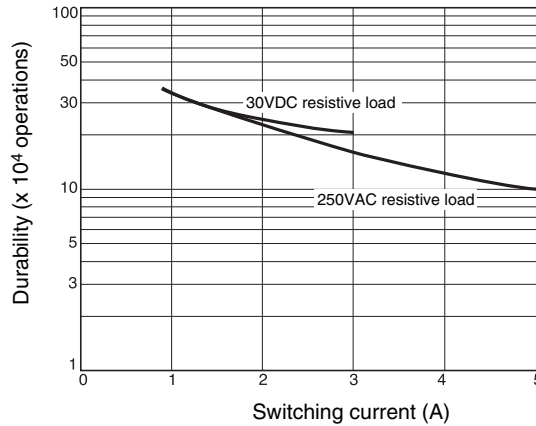

## ●Ambient Temperature vs. Maximum Coil Voltage

### Standard models

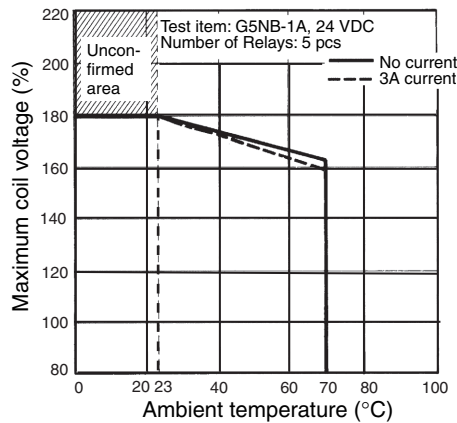

### High-capacity models

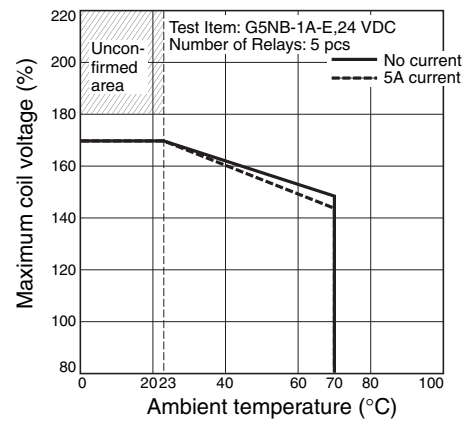

**Note:** The maximum coil voltage refers to the maximum value in a varying range of operating power voltage, not a continuous voltage.

## ●Shock malfunction

### Standard models

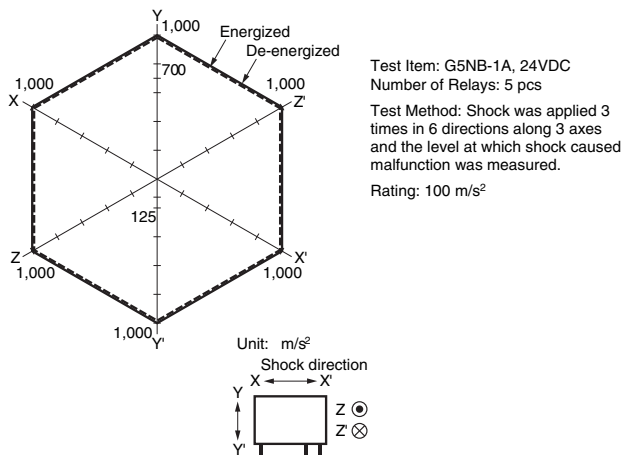

### High-capacity models

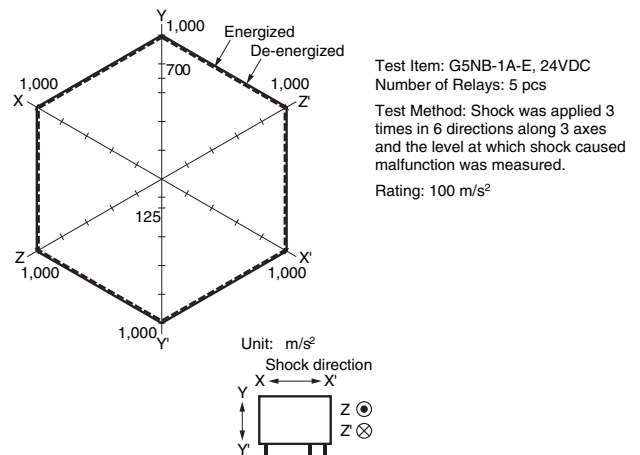

## ■Dimensions

(Unit: mm)

### G5NB-1A(4)(-E), G5NB-1A-E-HA

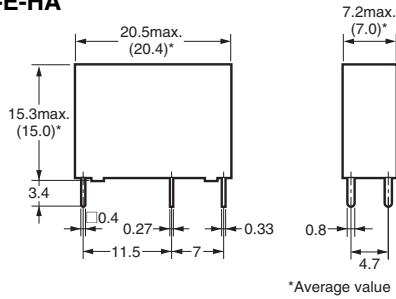
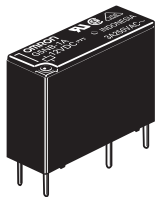

### PCB Mounting Holes (Bottom View) Tolerance: ±0.1 mm

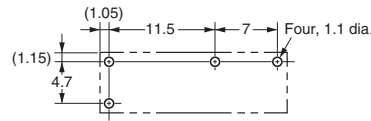

### Terminal Arrangement/ Internal Connections (Bottom View)

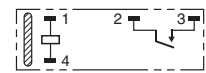

(No coil polarity)

## ■Approved Standards

The approval rating values for overseas standards are different from the performance values determined individually. Confirm the values before use.

●UL Recognized: (File No. E41515)

CSA Certified: (File No. LR31928)

Model	Contact form	Coil ratings	Contact ratings	Number of test operations
G5NB-1A(4)	SPST-NO (1a)	5~24V DC	3A 125V AC (Resistive) 70°C	6,000
G5NB-1A(4)-E			3A 30V DC (Resistive) 70°C	
G5NB-1A-E-HA	5A 250 V AC (Resistive) 85°C			
	5A 30 V DC (Resistive) 70°C			

●EN/IEC, VDE Certified (Registration No. 137575)

Model	Contact form	Coil ratings	Contact ratings	Number of test operations
G5NB-1A(4)	SPST-NO (1a)	5, 12, 18, 24V DC	3A 250V AC (Resistive) 85°C	100,000
			3A 30V DC (Resistive) 85°C	
G5NB-1A(4)-E			5A 250 V AC (Resistive) 85°C	10,000
G5NB-1A-E-HA			5A 30 V DC (Resistive) 85°C	
			3A 250V AC (Resistive) 85°C	100,000

Clearance distance	5.5 mm min.
Creepage distance	6.0 mm min.
Insulation material group	IIIa
Type of insulation coil-contact circuit	Reinforced (PD.2)
open contact circuit	Micro disconnection
Rated Insulation voltage	250 V
Pollution degree	2
Rated voltage system	250 V
Over voltage category	III
Category of protection according to IEC 61810-1	RT II (Flux protection) / RT III (Sealed)
Glow wire according to IEC 60335-1 ed.5	<HA Models only> GWT 750°C min. (IEC 60695-2-11) / GWFI 850°C min. (IEC 60695-2-12)
Tracking resistance according to IEC 60112	PTI 250 V min. (housing parts)

## ■Precautions

●Please refer to “PCB Relays Common Precautions” for correct use.

- Application examples provided in this document are for reference only. In actual applications, confirm equipment functions and safety before using the product.
- Consult your OMRON representative before using the product under conditions which are not described in the manual or applying the product to nuclear control systems, railroad systems, aviation systems, vehicles, combustion systems, medical equipment, amusement machines, safety equipment, and other systems or equipment that may have a serious influence on lives and property if used improperly. Make sure that the ratings and performance characteristics of the product provide a margin of safety for the system or equipment, and be sure to provide the system or equipment with double safety mechanisms.

Note: Do not use this document to operate the Unit.