

MechaTronix in LED

XSA-96 Xicato Pin Fin LED Cooler ϕ 111mm



Features & Benefits

- The XSA-96 Pin Fin LED cooler is specifically designed for luminaires using the Xicato LED modules. Mechanical compatibility with direct mounting of the LED modules to the LED cooler and thermal performance matching the lumen packages.
- For spot and downlight designs from 2,000 to 6,000 lumen
- Thermal resistance R_{th} 1.07°C/W
- Xicato thermal class Q (60° tilt angle, 40°C ambient)
- Modular design with mounting holes foreseen for direct mounting of Xicato XSM LED modules.
- Diameter 111mm - Standard height 80mm
Other heights on request
- Center hole for cable guidance
- Forged from highly conductive aluminum



Order Information

XICATO

Example : XSA-96-M3-B

XSA-96-M3- **1**

- 1** Anodising Color
 - B - Black
 - C - Clear
 - Z - Custom (specify)

The XSA-96 Xicato pin fin LED cooler is designed in this way that you can mount various LED modules on the same LED cooler

This LED cooler is thermally validated for Xicato and tested under various boundary conditions

MechaTronix in LED

XSA-96 Xicato Pin Fin LED Cooler ø111mm



Product Details

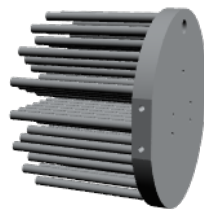

Model n°	XSA-96
Dimension (mm) ^{*1}	ø111 x h80
Volume (mm ³)	210075
Cooling Surface (mm ²)	115637
Weight (gr)	567
Thermal Resistance (°C/W) ^{*2}	1.07
Power Pd (W) ^{*3}	50
Heat Sink Material	AL1070

^{*1} 3D files are available in ParaSolid, STP and IGS on request

^{*2} The thermal resistance Rth is determined with a calibrated heat source of 30mm x 30mm central placed on the heat sink, Tamb 40° and an open environment. Reference data @ heat sink to ambient temperature rise Ths-amb 50°C
The thermal resistance of a LED cooler is not a fix value and will vary with the applied dissipated power Pd

^{*3} Dissipated power Pd. Reference data @ heat sink to ambient temperature rise Ths-amb 50°C
The maximal dissipated power needs to be verified in function of required case temperature Tc or junction temperature Tj and related to the estimated ambient temperature where the light fixture will be placed
Please be aware the dissipated power Pd is not the same as the electrical power Pe of a LED module

To calculate the dissipated power please use the following formula: $Pd = Pe \times (1 - \eta_L)$

Pd - Dissipated power

Pe - Electrical power

η_L = Light efficiency of the LED module

Notes:

- MechaTronix reserves the right to change products or specifications without prior notice.
- Mentioned models are an extraction of full product range.
- For specific mechanical adaptations please contact MechaTronix.

MechaTronix in LED

XSA-96 Xicato Pin Fin LED Cooler ϕ 111mm



Product Details

The XSA-96 Xicato Pin Fin LED cooler is standard foreseen from a variety of mounting holes which allow direct mounting of all Xicato Spot and down light LED modules and secondary optics on the LED heat sink.

In this way mechanical afterwork and related costs can be avoided, and lighting designers can standardize their designs on a limited number of LED coolers.

Below you find an overview of Xicato LED modules which standard fit on the XSA-96 LED cooler.

MechaTronix performs thermal validation tests on each of the LED modules mounted on the LED cooler and publishes this data in the LED brand thermal validation reports.

For a full overview of available LED coolers for Xicato LEDs, please refer to the Xicato LED cooler overview on www.led-heatsink.com/Download.php or scan the QR code here.



Xicato LED Modules

XICATO

Xicato is changing the way the world looks at light – and enabling everyone to experience it. Xicato believes that with better light, shoppers will buy more, diners will order more and guests will be happier and feel more comfortable. In turn, for owners, operators and managers of environments, better lighting will contribute to high sales, margins and brand perception.

Mounting indicator marks overview

MechaTronix recommends the use of a high thermal conductive interface between the LED module and the LED cooler. Either thermal grease, a thermal pad or a phase change thermal pad thickness 0.1-0.15mm is recommended. Thermal pads or phase change thermal pads can be pre-applied from MechaTronix.

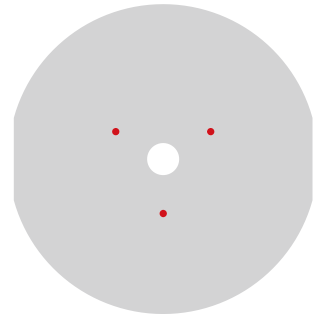

Xicato XIM LED modules

Model names

- XIM-19-8027-xx
- XIM-19-8030-xx
- XIM-19-8035-xx
- XIM-19-8040-xx
- XIM-19-V830-xx

Mounting

- Direct mounting with 3 screws M3 x 20mm
- Red indicator marks

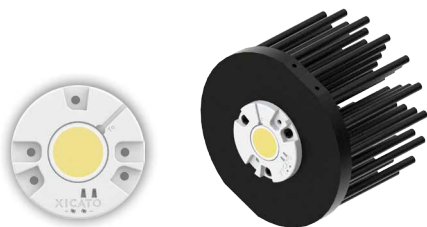

Xicato XTM LED modules

Model names

- XTM-19-8027-xx
- XTM-19-8030-xx
- XTM-19-8035-xx
- XTM-19-8040-xx
- XTM-19-V830-xx

Mounting

- Direct mounting with 3 screws M3 x 8mm
- Red indicator marks

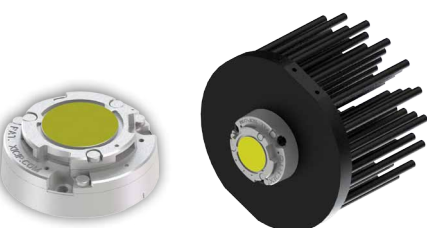

Xicato XSM LED modules

Model names

- XSM-8027-xxx
- XSM-8030-xxx
- XSM-8040-xxx
- XSM-9527-xxx
- XSM-9530-xxx
- XSM-9540-xxx
- XSM-V830-xxx

Mounting

- Direct mounting with 3 screws M3 x 12mm
- Red indicator marks

MechaTronix in LED

XSA-96 Xicato Pin Fin LED Cooler $\phi 111\text{mm}$



Drawings & Dimensions

Example: XSA-96-M3

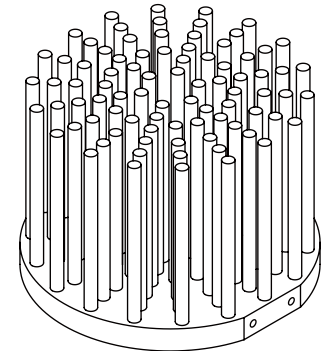
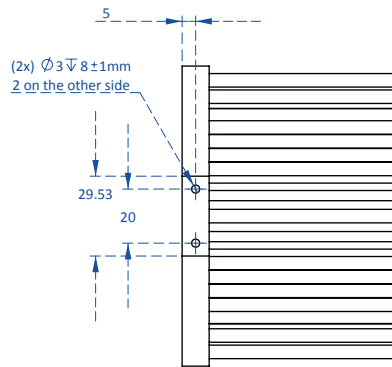
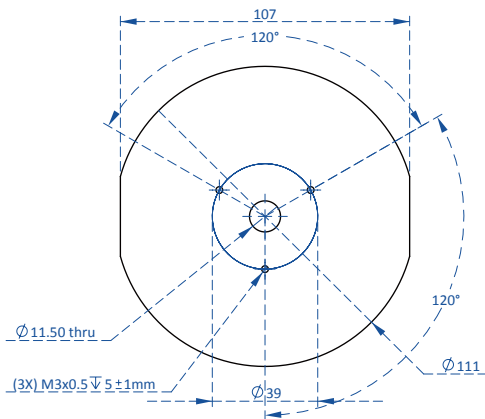

Thermal Data

$P_d = P_e \times (1 - \eta_L)$			LED Light efficiency, η_L (%)			Heat sink to ambient thermal resistance R_{hs-amb} ($^{\circ}\text{C}/\text{W}$)	Heat sink to ambient temperature rise T_{hs-amb} ($^{\circ}\text{C}$)
			17%	20%	25%		
Dissipated Power P_d (W)	20	Electrical Power P_e (W)	24	25	26.66	1.25	27.0
	30		36.14	37.5	40	1.18	35.2
	40		48.19	50	53.33	1.12	43.3
	50		60.24	62.5	66.66	1.06	51.4
	60		72.28	75	80	1.00	59.6
	70		84.33	87.5	93.33	0.94	67.7

Heat sink to ambient temperature rise T_{hs-amb} ($^{\circ}\text{C}$)

XSA-96

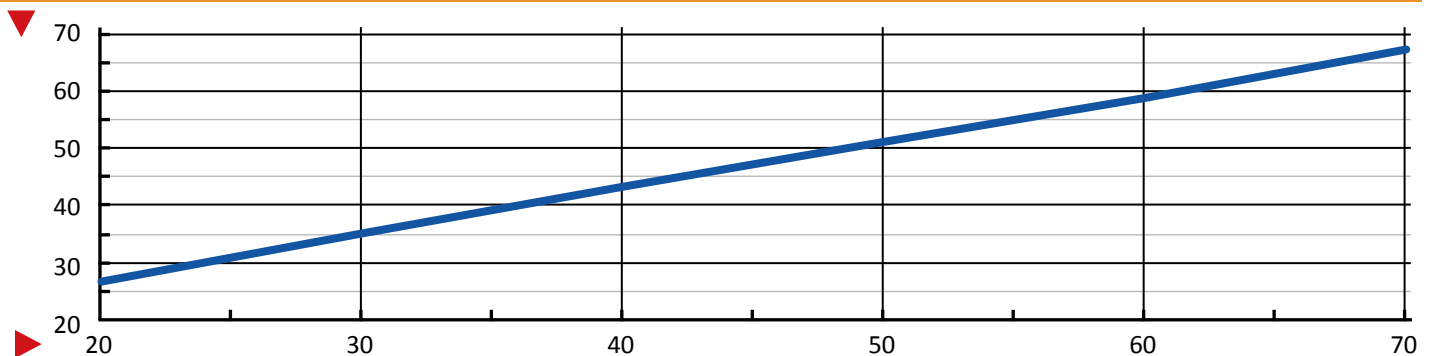

Dissipated Power P_d (W)